

(19)



(11)

EP 4 231 953 B1

(12)

EUROPEAN PATENT SPECIFICATION

(45) Date of publication and mention of the grant of the patent:
20.11.2024 Bulletin 2024/47

(21) Application number: **20960099.8**

(22) Date of filing: **26.10.2020**

(51) International Patent Classification (IPC):
A61B 18/18 ^(2006.01) **A61B 18/12** ^(2006.01)

(52) Cooperative Patent Classification (CPC):
A61B 18/1815; A61B 2018/00011;
A61B 2018/00017; A61B 2018/00023;
A61B 2018/00303; A61B 2018/00577;
A61B 2018/00642; A61B 2018/0066;
A61B 2018/00714; A61B 2018/00738;
A61B 2018/00785; A61B 2018/00898;
A61B 2018/1405

(86) International application number:
PCT/US2020/057383

(87) International publication number:
WO 2022/093177 (05.05.2022 Gazette 2022/18)

(54) **ABLATION PROBE SYSTEMS**

ABLATIONSSONDENSYSTEME

SYSTÈMES DE SONDE D'ABLATION

(84) Designated Contracting States:
AL AT BE BG CH CY CZ DE DK EE ES FI FR GB GR HR HU IE IS IT LI LT LU LV MC MK MT NL NO PL PT RO RS SE SI SK SM TR

(43) Date of publication of application:
30.08.2023 Bulletin 2023/35

(60) Divisional application:
24206550.6

(73) Proprietor: **TriAgenics, Inc.**
Redmond, Oregon 97756 (US)

(72) Inventors:
• **COLBY, Leigh E.**
Lino Lakes, Minnesota 55038 (US)

• **WATSON, David**
Redmond, OR 97756 (US)

(74) Representative: **Bhimani, Alan**
Spa IP & Consulting Limited
78 Leicester Lane
Leamington Spa CV32 7HH (GB)

(56) References cited:
EP-B1- 1 210 022 **WO-A1-2004/084748**
US-A1- 2004 147 915 **US-A1- 2011 077 635**
US-A1- 2016 151 113 **US-A1- 2018 261 922**
US-A1- 2020 197 089

EP 4 231 953 B1

Note: Within nine months of the publication of the mention of the grant of the European patent in the European Patent Bulletin, any person may give notice to the European Patent Office of opposition to that patent, in accordance with the Implementing Regulations. Notice of opposition shall not be deemed to have been filed until the opposition fee has been paid. (Art. 99(1) European Patent Convention).

Description

BACKGROUND

5 **[0001]** The present disclosure describes apparatuses, methods/procedures, and systems that generally relate to the technical field of ablation probes, and specifically relate to the technical field of microwave and radiofrequency ablation probes that have shaped and/or sized targeted tissue ablation zones that enable guided soft tissue ablation procedures that are more precise and predictable than procedures that are not guided.

10 **[0002]** The term "ablation" in the medical industry generally describes the removal of problematic (e.g. damaged, diseased, or otherwise undesired) tissue (targeted tissue) by less invasive techniques that generally employ a probe that operates through the cooling or heating of targeted tissue, although mechanical, electrical, chemical, and laser ablation technology can also be used. Whereas "resection" involves partially or completely removing an organ by conventional surgical methods (i.e. use of a scalpel or saw to cut out tissue), medical ablation generally involves partially or completely removing or destroying a layer (or layers) of targeted tissue through a probe that employs thermal or non-thermal technology with the aim of more selectively destroying the targeted tissue. The goal of ablation is to remove or destroy the targeted tissue (problematic tissue) with substantially less damage to surrounding tissue or structure compared to more invasive conventional surgical methods while restoring normal function. Use of ablation technology can be used to treat a variety of medical conditions ranging from serious to cosmetic. Some of the more common types of ablation include surface ablation (used to remove a layer of targeted tissue to treat discoloration, improve skin texture, or removing superficial lesions, warts, or tumors), cardiac ablation (such as radiofrequency ablation (RFA) that is used to destroy targeted tissue in the heart associated with irregular heartbeats), endometrial microwave ablation (used to destroy the lining of the uterus to reduce or stop abnormal bleeding of the uterus), bone marrow ablation (used to remove bone marrow in advance of a bone marrow transplant), brain surgery ablation (used to treat certain neurological disorders), or microwave ablation (used to treat liver tumors without physically resecting the tumors).

25 **[0003]** Ablation may be performed using microwaves (e.g. microwave ablation (MWA) and microwave endometrial ablation (MEA)), radiofrequencies (e.g. radiofrequency ablation (RFA)), lasers (e.g. LASIK surgery), ultrasound (e.g. ultra-high intensity ultrasound), chemicals (e.g. chemoablation), low or cold temperatures (e.g. cryoablation), high or hot temperatures, electricity (e.g. fulguration, hot tip or cauterization, and others), and mechanical processes (e.g. rotablation). Microwave ablation is a form of thermal ablation that uses electromagnetic waves in the microwave energy spectrum (300 MHz to 300 GHz) to produce tissue-heating effects to generate tissue necrosis within solid tumors to treat cancer. Microwave endometrial ablation, for example, is one use of microwave ablation which uses microwaves at a fixed frequency to destroy the basal layer of the endometrium and the glands (sparing the remainder of the uterus) by heating them to over sixty degrees Celsius (60°C). Another well-established use of microwave ablation is liver tumor ablation, which is commonly performed at 500 MHz to 2.45 GHz. Radiofrequency ablation (RFA) is a medical procedure in which part of the electrical conduction system of the heart, tumor, or other dysfunctional tissue is ablated using the heat generated from medium frequency alternating current (in the range of 300-500 kHz).

35 **[0004]** One use for ablation is tooth bud ablation. Third molar formation predictably causes lifelong issues including complications, pain, tooth decay, gum disease, and/or abscesses with a rate of nearly 99% over the life of patients. Unfortunately, surgical extraction of fully formed third molars has a host of risks and complications, such as painful post-extraction osteitis or "dry socket," severe infections, temporary and permanent nerve damage, significant pain, temporary and permanent temporomandibular (TMJ) damage, and more. Historically, there have been suggestions and attempts to prevent the formation of third molars on a prophylactic basis before these problematic teeth completely form - such as those of Dr. Henry in 1969, Drs. Gordon & Laskin in 1978, and more recently by Dr. Silvestri in 2004 - to eliminate the disease conditions they predictably cause while reducing (but not eliminating) the surgical hazards. However, such prior attempts at third-molar-formation prevention have been manual systems that were difficult to implement, inconsistent, unpredictable, un-repeatable because they were manual and - as a result - have never been adopted by dental professionals.

45 **[0005]** Exemplary systems and methods of guided ablation for tooth bud ablation, such as those described in U.S. Patent No. 9,402,693, U.S. Patent No. 9,827,068, U.S. Patent No. 9,855,112, U.S. Patent No. 10,022,202, U.S. Patent No. 10,265,140, U.S. Patent No. 10,285,778, U.S. Patent No. 10,298,255, U.S. Patent No. 10,299,885, U.S. Patent Publication No. US2011/0200961, U.S. Patent Publication No. US2016/0324597, U.S. Patent Publication No. US2017/0360528, U.S. Patent Publication No. US2018/0091169, U.S. Patent Publication No. US2018/0153640, U.S. Patent Publication No. US2018/0318038, PCT Publication No. WO/2010/132368, PCT Publication No. WO/2014/143014, and related U.S. and foreign patent applications, all of which were invented by the inventor of the present invention and are owned by the applicant of the present application.

55 **[0006]** The corresponding Therapeutic Tooth Bud Ablation Properties describe tooth bud ablation methods, systems, and procedures that result in tooth agenesis. These methods, systems, and procedures may include and/or use ablation probe tips and/or stents.

[0007] The NEUWAVE™ Microwave Ablation System is described as being able to ablate lesions with consistency and control to help protect non-targeted tissue. The NEUWAVE™ System includes features such as a computer controlled system for storing procedure data and ablation confirmation software to confirm technical success of procedures. It is described as having a burn pattern that controls the ablation distance past the probe tip by limiting the burn pattern past the tip. Even though NEUWAVE asserts that the PR probe "is the only probe available with a unique burn pattern that controls the ablation distance past the probe tip," the NEUWAVE PR microwave ablation probe has serious limitations. The ablation produced by the PR probe encompasses the tip in ten (10) seconds and then burns "proximally." This means that the burn pattern asymmetrically "creeps" or migrates (that may be referred to generically as "migrates" or variations thereof) up the ablation probe tip (generally away from the absolute tip and toward a handle) with a resulting burn pattern that is so oblong that it is "hot dog" shaped, thus making minimally invasive soft tissue ablation procedures impossible.

[0008] Ablation zone migration up the probe tip (generally away from the absolute tip and toward a handle) shaft is a known problem throughout the medical ablation community and numerous attempts have been made to control this problem. For example, U.S. Patent No. 7,611,508 to Yang et al. sets forth an antenna for microwave tumor ablation that has coaxial antenna conductors surrounded by an insulated sleeve of a length and size promoting destructive interference of axial microwave energy passing inside and outside of the sleeve to limit the tail (that, like "creep," may also be referred to generically as migration or variations thereof) of the burn pattern up the microwave ablation probe tip shaft. Yang's floating sleeve provides destructive wave interference or cancellation of the microwave signal radiating out of the antennas, yet this documentation shows that this technique still results in a zone of ablation that asymmetrically migrates up the probe length during soft tissue ablation with a pattern that is so oblong that it appears to be "hot dog" shaped, thus making minimally invasive soft tissue ablation procedures impossible.

[0009] US2011/077635 discloses a microwave antenna assembly having a feedline electrically connected to an elongated shaft by a choke electrical connector. The feedline includes co-axial antenna having an inner conductor and an outer conductor, an elongated shaft and a choke electrical connector. The elongated shaft at least partially surrounds the feedline and form a dielectric return lumen therebetween and the choke electrical connector surrounds at least a portion of the feedline and electrically connects the feedline outer conductor to the elongated shaft. A low-loss dielectric fluid is supplied between the inner conductor and the outer conductor of the feedline and forms a dielectric barrier therebetween. The low-loss dielectric fluid also forms a dielectric barrier between the outer conductor of the feedline and the elongated shaft and the choke electrical connector forms a plurality of apertures extending therethrough, the apertures forming at least a portion of the dielectric return lumen.

[0010] US2020/197089 discloses a microwave ablation probe including a probe body including a shielded portion and a radiation window that is at least partially transparent to microwave energy. The shielded portion includes a cannula, a coaxial cable within the probe body, and an antenna having a radiating portion for emission of microwave energy at a distal portion of the probe body, the radiating portion aligned with the radiation window. The probe body defines an irrigation path configured to carry cooling fluid to and from the distal portion of the probe body.

SUMMARY

[0011] The invention is defined in the appended claims.

[0012] Disclosed herein is an ablation probe tip having a shaft with an insertion end. The ablation probe tip may receive ablation means from an ablation source. The ablation probe tip is preferably for ablating targeted tissue. The shaft preferably includes a coaxial antenna. A center of ablation is preferably located within the coaxial antenna at least near the insertion end. A heat transfer layer preferably surrounds the coaxial antenna. The heat transfer layer is preferably spaced from the insertion end such that the center of ablation is between the heat transfer layer and the insertion end. A thermal reservoir preferably at least partially surrounds the heat transfer layer.

[0013] The ablation probe tip may have an ablation zone surrounding the center of ablation such that when the ablation means is provided to the ablation probe tip, the heat transfer layer provides ablation zone temperature control. The ablation probe tip may have an ablation zone surrounding the center of ablation such that when the ablation means is provided to the ablation probe tip, the heat transfer layer provides ablation zone temperature control by keeping peak temperatures below a predetermined temperature in the ablation zone. The ablation probe tip may have an ablation zone surrounding the center of ablation such that when the ablation means is provided to the ablation probe tip, the heat transfer layer provides passive cooling ablation zone temperature control. The ablation probe tip may have an ablation zone surrounding the center of ablation such that when the ablation means is provided to the ablation probe tip, the heat transfer layer provides tissue quenching ablation zone temperature control. The ablation probe tip may have an ablation zone surrounding the center of ablation such that when the ablation means is provided to the ablation probe tip, the thermal reservoir provides ablation zone temperature control. The ablation probe tip may have an ablation zone surrounding the center of ablation such that when the ablation means is provided to the ablation probe tip, the thermal reservoir provides ablation zone temperature control by keeping peak temperatures below a predetermined temperature

in the ablation zone. The ablation probe tip may have an ablation zone surrounding the center of ablation such that when the ablation means is provided to the ablation probe tip, the thermal reservoir prevents peak temperatures exceeding sixty degrees Celsius in the ablation zone. The ablation probe tip may have an ablation zone surrounding the center of ablation such that when the ablation means is provided to the ablation probe tip, the thermal reservoir prevents peak temperatures exceeding forty-five degrees Celsius in the ablation zone. The ablation probe tip may have an ablation zone surrounding the center of ablation such that when the ablation means is provided to the ablation probe tip, the thermal reservoir provides passive cooling ablation zone temperature control. The ablation probe tip may have an ablation zone surrounding the center of ablation such that when the ablation means is provided to the ablation probe tip, the thermal reservoir provides tissue quenching ablation zone temperature control. The ablation probe tip may have an ablation zone surrounding the center of ablation such that when the ablation means is provided to the ablation probe tip, the thermal reservoir provides thermal quenching ablation zone temperature control. The ablation probe tip may have an ablation zone surrounding the center of ablation such that when the ablation means is provided to the ablation probe tip, the heat transfer layer and the thermal reservoir provide ablation zone temperature control. The ablation probe tip may have an ablation zone surrounding the center of ablation such that when the ablation means is provided to the ablation probe tip, the heat transfer layer and the thermal reservoir provide ablation zone temperature control by keeping peak temperatures below a predetermined temperature in the ablation zone. The ablation probe tip may have an ablation zone surrounding the center of ablation such that when the ablation means is provided to the ablation probe tip, the heat transfer layer and the thermal reservoir provide passive cooling ablation zone temperature control. The ablation probe tip may have an ablation zone surrounding the center of ablation such that when the ablation means is provided to the ablation probe tip, the heat transfer layer and the thermal reservoir provide tissue quenching ablation zone temperature control. The ablation probe tip may have an ablation zone surrounding the center of ablation such that when the ablation means is provided to the ablation probe tip, the heat transfer layer and the thermal reservoir provide thermal quenching ablation zone temperature control.

[0014] The thermal reservoir may be a solid thermal reservoir. The thermal reservoir may be a fluid thermal reservoir. The thermal reservoir may form at least part of a hand piece. The thermal reservoir may form at least part of a hand piece and surround at least part of the heat transfer layer. The thermal reservoir may passively cool the heat transfer layer. The thermal reservoir may passively cool the heat transfer layer by absorbing heat from the heat transfer layer. The thermal reservoir may be selected from the group including a fluid thermal reservoir, an air thermal reservoir, a water thermal reservoir, an ice thermal reservoir, an aluminum thermal reservoir, a silver thermal reservoir, a copper thermal reservoir, a diamond thermal reservoir, and a superconductive thermal reservoir. The thermal reservoir may be a superconductive thermal reservoir made from at least one superconductive material selected from the group including boron nitride, graphene, graphene nanotubes, and pyrolytic graphite. The thermal reservoir may be a combination thermal reservoir made from a combination of at least two materials selected from the group including air, water, ice, aluminum, silver, copper, diamond, boron nitride, graphene, graphene nanotubes, and pyrolytic graphite.

[0015] The ablation probe tip may have at least one thermal-capacitance-control mechanism for controlling thermal capacitance or capacity of the ablation probe tip. The at least one thermal-capacitance-control mechanism is preferably selected from the group including: (a) means for controlling the temperature of the thermal reservoir; (b) means for controlling the location of the thermal reservoir; (c) means for controlling the mass of the thermal reservoir; (d) means for controlling the dimensions of the thermal reservoir; (e) means for controlling the volume of the thermal reservoir; (f) means for controlling the cross-sectional area of the heat transfer layer; (g) means for controlling the material from which the thermal reservoir is constructed; (h) means for controlling the mass of the heat transfer layer; (i) means for controlling the dimensions of the heat transfer layer; (j) means for controlling the volume of the heat transfer layer; (k) means for controlling the cross-sectional area of the heat transfer layer; (l) means for controlling the material from which the heat transfer layer is constructed; (m) means for controlling power applied to the ablation probe tip; (n) means for controlling energy applied to the ablation probe tip; and (o) means for controlling duration of an ablation cycle during which heat is applied. The at least one thermal-capacitance-control mechanism may be a plurality of thermal-capacitance-control mechanisms for controlling thermal capacitance of the ablation probe tip. The plurality of thermal-capacitance-control mechanisms are preferably selected from the group including: (a) means for controlling the temperature of the thermal reservoir; (b) means for controlling the location of the thermal reservoir; (c) means for controlling the mass of the thermal reservoir; (d) means for controlling the dimensions of the thermal reservoir; (e) means for controlling the volume of the thermal reservoir; (f) means for controlling the cross-sectional area of the heat transfer layer; (g) means for controlling the material from which the thermal reservoir is constructed; (h) means for controlling the mass of the heat transfer layer; (i) means for controlling the dimensions of the heat transfer layer; (j) means for controlling the volume of the heat transfer layer; (k) means for controlling the cross-sectional area of the heat transfer layer; (l) means for controlling the material from which the heat transfer layer is constructed; (m) means for controlling power applied to the ablation probe tip; (n) means for controlling energy applied to the ablation probe tip; and (o) means for controlling duration of an ablation cycle during which heat is applied.

[0016] The heat transfer layer may draw heat from the targeted tissue by allowing thermal energy to be conducted

preferentially up the heat transfer layer. The ablation probe tip may have passive cooling and active cooling. The coaxial antenna may include: (a) an inner conductor; (b) an annular dielectric insulator layer surrounding the inner conductor; and (c) an annular outer conductor surrounding the annular dielectric insulator layer. The ablation probe tip may further include: (a) an annular aperture defined in at least one outer layer of the coaxial antenna toward the insertion end; (b) the center of ablation surrounded by the annular aperture, the center of ablation being a focal region from which the ablation means radiates through the annular aperture to form an ablation zone; and (c) the heat transfer layer spaced from the insertion end such that the annular aperture is between the heat transfer layer and the insertion end.

[0017] The heat transfer layer may prevent the center of ablation from migrating up the shaft away from the insertion end. The heat transfer layer may be quenched by transferring thermal energy from the heat transfer layer into soft tissue surrounding the heat transfer layer. The coaxial antenna may be a near field antenna and/or a near field reactive antenna. The ablation probe tip may be a microwave ablation probe tip. The microwave ablation probe tip may receive microwave energy from the ablation source as the ablation means. The microwave energy may be delivered to the targeted tissue via the ablation probe tip. The provided microwave energy may have frequencies ranging from 500 MHz to 300 GHz. The ablation probe tip may be a radiofrequency ablation probe tip. The ablation probe tip may be a micro-ablation ablation probe tip. The ablation probe tip may have an ablation zone surrounding the center of ablation such that when the ablation means is provided to the ablation probe tip, the ablation zone is for selectively ablating the targeted tissue while mitigating damage to immediately adjacent collateral tissues.

[0018] Also disclosed herein is a method for cooling an ablation probe tip. The ablation probe tip receives ablation means from an ablation source. The ablation probe tip then ablates targeted tissue. The method includes providing the ablation probe tip, the ablation probe tip having a shaft with an insertion end, the shaft including a coaxial antenna, the coaxial antenna having a center of ablation located therein and near the insertion end, the coaxial antenna having a heat transfer layer surrounding and spaced from the insertion end such that the center of ablation is between the heat transfer layer and the insertion end, and a thermal reservoir that at least partially surrounds the heat transfer layer. The method includes predetermining an optimal temperature for the heat transfer layer. The method includes the thermal reservoir cooling the heat transfer layer to no higher than the optimal temperature.

[0019] The heat transfer layer may draw heat from the targeted tissue by allowing thermal energy to be conducted preferentially up the heat transfer layer. The thermal reservoir may passively cool the heat transfer layer to no higher than the optimal temperature. The method may include holding the heat transfer layer at the optimal temperature. The method may include holding the heat transfer layer to no higher than the optimal temperature. The method may include predetermining an optimal temperature range for the heat transfer layer and the thermal reservoir cooling the heat transfer layer such that the temperature of the heat transfer layer is within the optimal temperature range.

[0020] The method preferably includes controlling the thermal capacitance or capacity of the ablation probe tip using at least one thermal-capacitance-control mechanism. Controlling the thermal capacitance or the capacity of the ablation probe tip may be accomplished by controlling the temperature of the thermal reservoir, controlling the location of the thermal reservoir, controlling the mass of the thermal reservoir, controlling the dimensions of the thermal reservoir, controlling the volume of the thermal reservoir, controlling the cross-sectional area of the thermal reservoir, controlling the material from which the thermal reservoir is constructed, controlling the mass of the heat transfer layer, controlling the dimensions of the heat transfer layer, controlling the volume of the heat transfer layer, controlling the cross-sectional area of the heat transfer layer, controlling the material from which the heat transfer layer is constructed, controlling power applied to the ablation probe tip, controlling energy applied to the ablation probe tip, and/or controlling duration of the ablation cycle.

[0021] The method may include quenching the heat transfer layer by transferring thermal energy from the heat transfer layer into soft tissue surrounding the heat transfer layer. The method may include the heat transfer layer preventing the center of ablation from migrating up the shaft away from the insertion end. The method may include actively cooling the ablation probe tip. The method may include the ablation probe tip receiving microwave energy from the ablation source as the ablation means, and delivering the microwave energy to the targeted tissue via the ablation probe tip. The microwave energy may be at frequencies ranging from 500 MHz to 300 GHz.

[0022] The present disclosure describes apparatuses, methods/procedures, and systems that generally relate to the technical field of medical ablation probes, and specifically relate to the technical field of microwave ablation probes and radiofrequency ablation probes that deliver shaped and/or sized targeted tissue ablation zones along with the ability to eliminate migration of the ablation zone (the burn pattern) up the probe tip shaft through a stationary center of ablation while simultaneously controlling power loading (power density) into the tissue to maximize or minimize peak temperatures in the active heating zone in the targeted ablation tissue.

[0023] A first preferred ablation probe tip preferably has a shaft with an insertion end. The ablation probe tip preferably receives ablation means from an ablation source. The ablation probe tip is preferably for ablating targeted tissue. The ablation probe tip preferably includes: the shaft, an annular aperture, and a center of ablation. The shaft preferably includes a coaxial antenna. The annular aperture is preferably defined in at least one outer layer of the coaxial antenna toward the insertion end. The center of ablation is preferably located within the coaxial antenna and surrounded by the

annular aperture. The center of ablation can be considered a focal region from which the ablation means radiates through the annular aperture to form an ablation zone. The ablation zone preferably has a predetermined power loading density in the ablation zone.

5 [0024] In one alternative of the first preferred ablation probe tip, the ablation zone is for selectively ablating the targeted tissue while mitigating damage to immediately adjacent collateral tissues. In one alternative of the first preferred ablation probe tip, at least some of the targeted tissue is destroyed by the ablation zone.

10 [0025] In one alternative of the first preferred ablation probe tip, the annular aperture is preferably a short annular aperture that preferably creates a short active heating zone surrounding the annular aperture. The short active heating zone preferably creates high power loading in the ablation zone. The short active heating zone preferably creates high peak temperatures in the ablation zone.

15 [0026] In one alternative of the first preferred ablation probe tip, the annular aperture is preferably a medium annular aperture that preferably creates a medium active heating zone surrounding the annular aperture. The medium active heating zone preferably creates medium power loading in the ablation zone. The medium active heating zone preferably creates medium peak temperatures in the ablation zone.

20 [0027] In one alternative of the first preferred ablation probe tip, the annular aperture is preferably a long annular aperture that preferably creates a long active heating zone surrounding the annular aperture. The long active heating zone preferably creates low power loading in the ablation zone. The long active heating zone preferably creates low peak temperatures in the ablation zone.

25 [0028] In one alternative of the first preferred ablation probe tip, the coaxial antenna is preferably a near field antenna. The center of ablation is preferably a stationary center of ablation. The near field antenna preferably prevents the center of ablation from migrating up the shaft away from the insertion end.

30 [0029] One alternative of the first preferred ablation probe tip further includes an annular heat transfer layer surrounding the coaxial antenna. The annular heat transfer layer may surround the coaxial antenna and be spaced from the insertion end such that the annular aperture is between the annular heat transfer layer and the insertion end. The annular heat transfer layer preferably prevents the center of ablation from migrating up the shaft away from the insertion end.

35 [0030] In one alternative of the first preferred ablation probe tip, the ablation zone preferably has a predetermined shape selected from the group consisting of oblate, spherical, and oblong.

40 [0031] One alternative of the first preferred ablation probe tip further includes an annular heat transfer layer surrounding the coaxial antenna and spaced from the insertion end such that the annular aperture is between the annular heat transfer layer and the insertion end. The ablation zone preferably has a predetermined shape that is determined by an aperture offset. The aperture offset is preferably a distance between the center of ablation and an annular edge of the annular heat transfer layer. An oblate ablation zone preferably has a relatively short aperture offset. An oblong ablation zone preferably has a relatively long aperture offset. A spherical ablation zone preferably has an aperture offset between the aperture offsets of the oblate ablation zone and the oblong ablation zone.

45 [0032] One alternative of the first preferred ablation probe tip further includes an annular heat transfer layer that surrounds the coaxial antenna. The coaxial antenna further includes an insulation annular layer annularly surrounding the coaxial antenna. The annular heat transfer layer preferably annularly surrounds the insulation annular layer.

50 [0033] In one alternative of the first preferred ablation probe tip, an antenna end load is preferably positioned between the annular aperture and the insertion end. The antenna end load may concentrate energy density and increase power loading.

55 [0034] One alternative of the first preferred ablation probe tip further includes an annular heat transfer layer surrounding the coaxial antenna and spaced from the insertion end such that the annular aperture is between the annular heat transfer layer and the insertion end. The annular heat transfer layer preferably has high thermal conductivity and is preferably electrically conductive.

[0035] In one alternative of the first preferred ablation probe tip, the coaxial antenna includes an inner conductor, an annular dielectric insulator layer surrounding the inner conductor, and an annular outer conductor surrounding the annular dielectric insulator layer. The annular aperture exposes an annular ring of the annular dielectric insulator layer.

[0036] In one alternative of the first preferred ablation probe tip, the ablation probe tip is preferably part of a surgical ablation kit that includes an ablation source, a hand piece, a stent, and a prescription. The prescription preferably includes at least one setting or parameter selected from the group consisting of: ablation energy dose tolerances, levels of energy, and duration of energy deliverance.

[0037] In one alternative of the first preferred ablation probe tip, the ablation probe tip preferably works in conjunction with a stent. The stent preferably has a surgical guide. The surgical guide is preferably for guiding the ablation probe tip so that the center of ablation is within tissue.

[0038] In one alternative of the first preferred ablation probe tip, the coaxial antenna is preferably a near field reactive antenna.

[0039] One alternative of the first preferred ablation probe tip further includes an annular heat transfer layer surrounding the coaxial antenna and spaced from the insertion end such that the annular aperture is between the annular heat

transfer layer and the insertion end. Preferably, the annular heat transfer layer blocks the ablation means from migrating up the shaft away from the insertion end. Preferably, the annular heat transfer layer allows thermal energy from the ablation zone to conduct up the shaft away from the insertion end.

5 [0040] In one alternative of the first preferred ablation probe tip, the ablation probe tip is preferably part of an ablation probe system that preferably has a peak temperature intra-operative control selected from the group consisting of: passive cooling, active cooling, and a combination of passive and active cooling.

10 [0041] One alternative of the first preferred ablation probe tip further includes an annular heat transfer layer surrounding the coaxial antenna and spaced from the insertion end such that the annular aperture is between the annular heat transfer layer and the insertion end. The annular heat transfer layer is preferably quenched by transferring thermal energy from the annular heat transfer layer into soft tissue surrounding the annular heat transfer layer.

15 [0042] In one alternative of the first preferred ablation probe tip, the ablation probe tip is preferably part of an ablation probe system that preferably has intra-operative control of a volume of the ablation zone. In one alternative of the first preferred ablation probe tip, the ablation probe tip is preferably part of an ablation probe system that preferably has intra-operative control of a diameter of the ablation zone.

20 [0043] In one alternative of the first preferred ablation probe tip, the ablation probe tip and the ablation means together allow for at least one intra-operative control selected from the group consisting of: position of the ablation zone, shaping of the ablation zone, centering of the ablation zone, peak temperature of the ablation zone, volume of the ablation zone, and diameter of the ablation zone.

25 [0044] In one alternative of the first preferred ablation probe tip, the ablation probe tip is preferably a micro-ablation ablation probe tip.

30 [0045] In one alternative of the first preferred ablation probe tip, the ablation probe tip is preferably a microwave ablation probe tip, and the microwave ablation probe tip may receive microwave energy from the ablation source as the ablation means. The microwave energy may be delivered to the targeted tissue via the ablation probe tip. The ablation source may provide microwave energy at frequencies ranging from 500 MHz to 300 GHz.

35 [0046] In one alternative of the first preferred ablation probe tip, the ablation probe tip is preferably a radiofrequency ablation probe tip.

40 [0047] A second preferred ablation probe tip preferably has a shaft with an insertion end. The ablation probe tip preferably receives ablation means from an ablation source. The ablation probe tip is preferably for ablating targeted tissue. The ablation probe tip preferably includes: the shaft, an annular aperture, and a center of ablation. The shaft preferably includes a coaxial antenna. The annular aperture is preferably defined in at least one outer layer of the coaxial antenna toward the insertion end. The center of ablation is preferably located within the coaxial antenna and surrounded by the annular aperture. The center of ablation can be considered a focal region from which the ablation means radiates through the annular aperture to form an ablation zone. The ablation zone preferably has a predetermined peak temperature in the ablation zone.

45 [0048] In one alternative of the second preferred ablation probe tip, the ablation zone is for selectively ablating the targeted tissue while mitigating damage to immediately adjacent collateral tissues. In one alternative of the second preferred ablation probe tip, at least some of the targeted tissue is destroyed by the ablation zone.

50 [0049] In one alternative of the second preferred ablation probe tip, the annular aperture is preferably a short annular aperture that preferably creates a short active heating zone surrounding the annular aperture. The short active heating zone preferably creates high power loading in the ablation zone. The short active heating zone preferably creates high peak temperatures in the ablation zone.

55 [0050] In one alternative of the second preferred ablation probe tip, the annular aperture is preferably a medium annular aperture that preferably creates a medium active heating zone surrounding the annular aperture. The medium active heating zone preferably creates medium power loading in the ablation zone. The medium active heating zone preferably creates medium peak temperatures in the ablation zone.

[0051] In one alternative of the second preferred ablation probe tip, the annular aperture is preferably a long annular aperture that preferably creates a long active heating zone surrounding the annular aperture. The long active heating zone preferably creates low power loading in the ablation zone. The long active heating zone preferably creates low peak temperatures in the ablation zone.

[0052] In one alternative of the second preferred ablation probe tip, the coaxial antenna is preferably a near field antenna. The center of ablation is preferably a stationary center of ablation. The near field antenna preferably prevents the center of ablation from migrating up the shaft away from the insertion end.

[0053] One alternative of the second preferred ablation probe tip further includes an annular heat transfer layer surrounding the coaxial antenna. The annular heat transfer layer may surround the coaxial antenna and be spaced from the insertion end such that the annular aperture is between the annular heat transfer layer and the insertion end. The annular heat transfer layer preferably prevents the center of ablation from migrating up the shaft away from the insertion end.

[0054] In one alternative of the second preferred ablation probe tip, the ablation zone preferably has a predetermined

shape selected from the group consisting of oblate, spherical, and oblong.

5 [0055] One alternative of the second preferred ablation probe tip further includes an annular heat transfer layer surrounding the coaxial antenna and spaced from the insertion end such that the annular aperture is between the annular heat transfer layer and the insertion end. The ablation zone preferably has a predetermined shape that is determined by an aperture offset. The aperture offset is preferably a distance between the center of ablation and an annular edge of the annular heat transfer layer. An oblate ablation zone preferably has a relatively short aperture offset. An oblong ablation zone preferably has a relatively long aperture offset. A spherical ablation zone preferably has an aperture offset between the aperture offsets of the oblate ablation zone and the oblong ablation zone.

10 [0056] One alternative of the second preferred ablation probe tip further includes an annular heat transfer layer that surrounds the coaxial antenna. The coaxial antenna further includes an insulation annular layer annularly surrounding the coaxial antenna. The annular heat transfer layer preferably annularly surrounds the insulation annular layer.

[0057] In one alternative of the second preferred ablation probe tip, an antenna end load is preferably positioned between the annular aperture and the insertion end. The antenna end load may concentrate energy density and increase power loading.

15 [0058] One alternative of the second preferred ablation probe tip further includes an annular heat transfer layer surrounding the coaxial antenna and spaced from the insertion end such that the annular aperture is between the annular heat transfer layer and the insertion end. The annular heat transfer layer preferably has high thermal conductivity and is preferably electrically conductive.

20 [0059] In one alternative of the second preferred ablation probe tip, the coaxial antenna includes an inner conductor, an annular dielectric insulator layer surrounding the inner conductor, and an annular outer conductor surrounding the annular dielectric insulator layer. The annular aperture exposes an annular ring of the annular dielectric insulator layer.

[0060] In one alternative of the second preferred ablation probe tip, the ablation probe tip is preferably part of a surgical ablation kit that includes an ablation source, a hand piece, a stent, and a prescription. The prescription preferably includes at least one setting or parameter selected from the group consisting of: ablation energy dose tolerances, levels of energy, and duration of energy deliverance.

25 [0061] In one alternative of the second preferred ablation probe tip, the ablation probe tip preferably works in conjunction with a stent. The stent preferably has a surgical guide. The surgical guide is preferably for guiding the ablation probe tip so that the center of ablation is within tissue.

30 [0062] In one alternative of the second preferred ablation probe tip, the coaxial antenna is preferably a near field reactive antenna.

[0063] One alternative of the second preferred ablation probe tip further includes an annular heat transfer layer surrounding the coaxial antenna and spaced from the insertion end such that the annular aperture is between the annular heat transfer layer and the insertion end. Preferably, the annular heat transfer layer blocks the ablation means from migrating up the shaft away from the insertion end. Preferably, the annular heat transfer layer allows thermal energy from the ablation zone to conduct up the shaft away from the insertion end.

35 [0064] In one alternative of the second preferred ablation probe tip, the ablation probe tip is preferably part of an ablation probe system that preferably has a peak temperature intra-operative control selected from the group consisting of: passive cooling, active cooling, and a combination of passive and active cooling.

40 [0065] One alternative of the second preferred ablation probe tip further includes an annular heat transfer layer surrounding the coaxial antenna and spaced from the insertion end such that the annular aperture is between the annular heat transfer layer and the insertion end. The annular heat transfer layer is preferably quenched by transferring thermal energy from the annular heat transfer layer into soft tissue surrounding the annular heat transfer layer.

[0066] In one alternative of the second preferred ablation probe tip, the ablation probe tip is preferably part of an ablation probe system that preferably has intra-operative control of a volume of the ablation zone. In one alternative of the second preferred ablation probe tip, the ablation probe tip is preferably part of an ablation probe system that preferably has intra-operative control of a diameter of the ablation zone.

45 [0067] In one alternative of the second preferred ablation probe tip, the ablation probe tip and the ablation means together allow for at least one intra-operative control selected from the group consisting of: position of the ablation zone, shaping of the ablation zone, centering of the ablation zone, peak temperature of the ablation zone, volume of the ablation zone, and diameter of the ablation zone.

50 [0068] In one alternative of the second preferred ablation probe tip, the ablation probe tip is preferably a micro-ablation ablation probe tip.

[0069] In one alternative of the second preferred ablation probe tip, the ablation probe tip is preferably a microwave ablation probe tip, and the microwave ablation probe tip may receive microwave energy from the ablation source as the ablation means. The microwave energy may be delivered to the targeted tissue via the ablation probe tip. The ablation source may provide microwave energy at frequencies ranging from 500 MHz to 300 GHz.

55 [0070] In one alternative of the second preferred ablation probe tip, the ablation probe tip is preferably a radiofrequency ablation probe tip.

5 [0071] A third preferred ablation probe tip preferably has a shaft with an insertion end. The ablation probe tip preferably receives ablation means from an ablation source. The ablation probe tip is preferably for ablating targeted tissue. The ablation probe tip preferably includes: the shaft, an annular aperture, and a center of ablation. The shaft preferably includes a coaxial antenna. The annular aperture is preferably defined in at least one outer layer of the coaxial antenna toward the insertion end. The center of ablation is preferably located within the coaxial antenna and surrounded by the annular aperture. The center of ablation can be considered a focal region from which the ablation means radiates through the annular aperture to form an ablation zone. The ablation zone preferably has an annular aperture and a power loading density in the ablation zone, the annular aperture and the power loading density being selected from the group consisting of: (a) a short annular aperture and high power loading; (b) a medium annular aperture and medium power loading; and (c) a long annular aperture and low power loading.

10 [0072] In one alternative of the third preferred ablation probe tip, the ablation zone is for selectively ablating the targeted tissue while mitigating damage to immediately adjacent collateral tissues. In one alternative of the third preferred ablation probe tip, at least some of the targeted tissue is destroyed by the ablation zone.

15 [0073] In one alternative of the third preferred ablation probe tip, the ablation zone preferably has a peak temperature in the ablation zone selected from the group consisting of: (a) if the annular aperture is a short annular aperture, the peak temperature in the ablation zone is a high peak temperature; (b) if the annular aperture is a medium annular aperture, the peak temperature in the ablation zone is a medium peak temperature; and (c) if the annular aperture is a long annular aperture, the peak temperature in the ablation zone is a low peak temperature.

20 [0074] In one alternative of the third preferred ablation probe tip, the coaxial antenna is preferably a near field antenna. The center of ablation is preferably a stationary center of ablation. The near field antenna preferably prevents the center of ablation from migrating up the shaft away from the insertion end.

25 [0075] One alternative of the third preferred ablation probe tip further includes an annular heat transfer layer surrounding the coaxial antenna. The annular heat transfer layer may surround the coaxial antenna and be spaced from the insertion end such that the annular aperture is between the annular heat transfer layer and the insertion end. The annular heat transfer layer preferably prevents the center of ablation from migrating up the shaft away from the insertion end.

[0076] In one alternative of the third preferred ablation probe tip, the ablation zone preferably has a predetermined shape selected from the group consisting of oblate, spherical, and oblong.

30 [0077] One alternative of the third preferred ablation probe tip further includes an annular heat transfer layer surrounding the coaxial antenna and spaced from the insertion end such that the annular aperture is between the annular heat transfer layer and the insertion end. The ablation zone preferably has a predetermined shape that is determined by an aperture offset. The aperture offset is preferably a distance between the center of ablation and an annular edge of the annular heat transfer layer. An oblate ablation zone preferably has a relatively short aperture offset. An oblong ablation zone preferably has a relatively long aperture offset. A spherical ablation zone preferably has an aperture offset between the aperture offsets of the oblate ablation zone and the oblong ablation zone.

35 [0078] One alternative of the third preferred ablation probe tip further includes an annular heat transfer layer that surrounds the coaxial antenna. The coaxial antenna further includes an insulation annular layer annularly surrounding the coaxial antenna. The annular heat transfer layer preferably annularly surrounds the insulation annular layer.

40 [0079] In one alternative of the third preferred ablation probe tip, an antenna end load is preferably positioned between the annular aperture and the insertion end. The antenna end load may concentrate energy density and increase power loading.

[0080] One alternative of the third preferred ablation probe tip further includes an annular heat transfer layer surrounding the coaxial antenna and spaced from the insertion end such that the annular aperture is between the annular heat transfer layer and the insertion end. The annular heat transfer layer preferably has high thermal conductivity and is preferably electrically conductive.

45 [0081] In one alternative of the third preferred ablation probe tip, the coaxial antenna includes an inner conductor, an annular dielectric insulator layer surrounding the inner conductor, and an annular outer conductor surrounding the annular dielectric insulator layer. The annular aperture exposes an annular ring of the annular dielectric insulator layer.

50 [0082] In one alternative of the third preferred ablation probe tip, the ablation probe tip is preferably part of a surgical ablation kit that includes an ablation source, a hand piece, a stent, and a prescription. The prescription preferably includes at least one setting or parameter selected from the group consisting of: ablation energy dose tolerances, levels of energy, and duration of energy deliverance.

[0083] In one alternative of the third preferred ablation probe tip, the ablation probe tip preferably works in conjunction with a stent. The stent preferably has a surgical guide. The surgical guide is preferably for guiding the ablation probe tip so that the center of ablation is within tissue.

55 [0084] In one alternative of the third preferred ablation probe tip, the coaxial antenna is preferably a near field reactive antenna.

[0085] One alternative of the third preferred ablation probe tip further includes an annular heat transfer layer surrounding the coaxial antenna and spaced from the insertion end such that the annular aperture is between the annular heat

transfer layer and the insertion end. Preferably, the annular heat transfer layer blocks the ablation means from migrating up the shaft away from the insertion end. Preferably, the annular heat transfer layer allows thermal energy from the ablation zone to conduct up the shaft away from the insertion end.

5 **[0086]** In one alternative of the third preferred ablation probe tip, the ablation probe tip is preferably part of an ablation probe system that preferably has a peak temperature intra-operative control selected from the group consisting of: passive cooling, active cooling, and a combination of passive and active cooling.

10 **[0087]** One alternative of the third preferred ablation probe tip further includes an annular heat transfer layer surrounding the coaxial antenna and spaced from the insertion end such that the annular aperture is between the annular heat transfer layer and the insertion end. The annular heat transfer layer is preferably quenched by transferring thermal energy from the annular heat transfer layer into soft tissue surrounding the annular heat transfer layer.

15 **[0088]** In one alternative of the third preferred ablation probe tip, the ablation probe tip is preferably part of an ablation probe system that preferably has intra-operative control of a volume of the ablation zone. In one alternative of the third preferred ablation probe tip, the ablation probe tip is preferably part of an ablation probe system that preferably has intra-operative control of a diameter of the ablation zone.

20 **[0089]** In one alternative of the third preferred ablation probe tip, the ablation probe tip and the ablation means together allow for at least one intra-operative control selected from the group consisting of: position of the ablation zone, shaping of the ablation zone, centering of the ablation zone, peak temperature of the ablation zone, volume of the ablation zone, and diameter of the ablation zone.

25 **[0090]** In one alternative of the third preferred ablation probe tip, the ablation probe tip is preferably a micro-ablation ablation probe tip.

30 **[0091]** In one alternative of the third preferred ablation probe tip, the ablation probe tip is preferably a microwave ablation probe tip and the microwave ablation probe tip may receive microwave energy from the ablation source as the ablation means. The microwave energy may be delivered to the targeted tissue via the ablation probe tip. The ablation source may provide microwave energy at frequencies ranging from 500 MHz to 300 GHz.

35 **[0092]** In one alternative of the third preferred ablation probe tip, the ablation probe tip is preferably a radiofrequency ablation probe tip.

40 **[0093]** A fourth preferred ablation probe tip preferably has a shaft with an insertion end. The ablation probe tip preferably receives ablation means from an ablation source. The ablation probe tip is preferably for ablating targeted tissue. The ablation probe tip preferably includes: the shaft, an annular aperture, and a center of ablation. The shaft preferably includes a coaxial antenna. The annular aperture is preferably defined in at least one outer layer of the coaxial antenna toward the insertion end. The center of ablation is preferably located within the coaxial antenna and surrounded by the annular aperture. The center of ablation can be considered a focal region from which the ablation means radiates through the annular aperture to form an ablation zone. The ablation zone preferably has an annular aperture and a peak temperature in the ablation zone, the annular aperture and the peak temperature selected from the group consisting of: (i) a short annular aperture and high peak temperature; (ii) a medium annular aperture and medium peak temperature; and (iii) a long annular aperture and low peak temperature.

45 **[0094]** In one alternative of the fourth preferred ablation probe tip, the ablation zone is for selectively ablating the targeted tissue while mitigating damage to immediately adjacent collateral tissues. In one alternative of the fourth preferred ablation probe tip, at least some of the targeted tissue is destroyed by the ablation zone.

50 **[0095]** In one alternative of the fourth preferred ablation probe tip, the coaxial antenna is preferably a near field antenna. The center of ablation is preferably a stationary center of ablation. The near field antenna preferably prevents the center of ablation from migrating up the shaft away from the insertion end.

55 **[0096]** One alternative of the fourth preferred ablation probe tip further includes an annular heat transfer layer surrounding the coaxial antenna. The annular heat transfer layer may surround the coaxial antenna and be spaced from the insertion end such that the annular aperture is between the annular heat transfer layer and the insertion end. The annular heat transfer layer preferably prevents the center of ablation from migrating up the shaft away from the insertion end.

[0097] In one alternative of the fourth preferred ablation probe tip, the ablation zone preferably has a predetermined shape selected from the group consisting of oblate, spherical, and oblong.

[0098] One alternative of the fourth preferred ablation probe tip further includes an annular heat transfer layer surrounding the coaxial antenna and spaced from the insertion end such that the annular aperture is between the annular heat transfer layer and the insertion end. The ablation zone preferably has a predetermined shape that is determined by an aperture offset. The aperture offset is preferably a distance between the center of ablation and an annular edge of the annular heat transfer layer. An oblate ablation zone preferably has a relatively short aperture offset. An oblong ablation zone preferably has a relatively long aperture offset. A spherical ablation zone preferably has an aperture offset between the aperture offsets of the oblate ablation zone and the oblong ablation zone.

[0099] One alternative of the fourth preferred ablation probe tip further includes an annular heat transfer layer that surrounds the coaxial antenna. The coaxial antenna further includes an insulation annular layer annularly surrounding

the coaxial antenna. The annular heat transfer layer preferably annularly surrounds the insulation annular layer.

[0100] In one alternative of the fourth preferred ablation probe tip, an antenna end load is preferably positioned between the annular aperture and the insertion end. The antenna end load may concentrate energy density and increase power loading.

[0101] One alternative of the fourth preferred ablation probe tip further includes an annular heat transfer layer surrounding the coaxial antenna and spaced from the insertion end such that the annular aperture is between the annular heat transfer layer and the insertion end. The annular heat transfer layer preferably has high thermal conductivity and is preferably electrically conductive.

[0102] In one alternative of the fourth preferred ablation probe tip, the coaxial antenna includes an inner conductor, an annular dielectric insulator layer surrounding the inner conductor, and an annular outer conductor surrounding the annular dielectric insulator layer. The annular aperture exposes an annular ring of the annular dielectric insulator layer.

[0103] In one alternative of the fourth preferred ablation probe tip, the ablation probe tip is preferably part of a surgical ablation kit that includes an ablation source, a hand piece, a stent, and a prescription. The prescription preferably includes at least one setting or parameter selected from the group consisting of: ablation energy dose tolerances, levels of energy, and duration of energy deliverance.

[0104] In one alternative of the fourth preferred ablation probe tip, the ablation probe tip preferably works in conjunction with a stent. The stent preferably has a surgical guide. The surgical guide is preferably for guiding the ablation probe tip so that the center of ablation is within tissue.

[0105] In one alternative of the fourth preferred ablation probe tip, the coaxial antenna is preferably a near field reactive antenna.

[0106] One alternative of the fourth preferred ablation probe tip further includes an annular heat transfer layer surrounding the coaxial antenna and spaced from the insertion end such that the annular aperture is between the annular heat transfer layer and the insertion end. Preferably, the annular heat transfer layer blocks the ablation means from migrating up the shaft away from the insertion end. Preferably, the annular heat transfer layer also allows thermal energy from the ablation zone to conduct up the shaft away from the insertion end.

[0107] In one alternative of the fourth preferred ablation probe tip, the ablation probe tip is preferably part of an ablation probe system that preferably has a peak temperature intra-operative control selected from the group consisting of: passive cooling, active cooling, and a combination of passive and active cooling.

[0108] One alternative of the fourth preferred ablation probe tip further includes an annular heat transfer layer surrounding the coaxial antenna and spaced from the insertion end such that the annular aperture is between the annular heat transfer layer and the insertion end. The annular heat transfer layer is preferably quenched by transferring thermal energy from the annular heat transfer layer into soft tissue surrounding the annular heat transfer layer.

[0109] In one alternative of the fourth preferred ablation probe tip, the ablation probe tip is preferably part of an ablation probe system that preferably has intra-operative control of a volume of the ablation zone. In one alternative of the fourth preferred ablation probe tip, the ablation probe tip is preferably part of an ablation probe system that preferably has intra-operative control of a diameter of the ablation zone.

[0110] In one alternative of the fourth preferred ablation probe tip, the ablation probe tip and the ablation means together allow for at least one intra-operative control selected from the group consisting of: position of the ablation zone, shaping of the ablation zone, centering of the ablation zone, peak temperature of the ablation zone, volume of the ablation zone, and diameter of the ablation zone.

[0111] In one alternative of the fourth preferred ablation probe tip, the ablation probe tip is preferably a micro-ablation ablation probe tip.

[0112] In one alternative of the fourth preferred ablation probe tip, the ablation probe tip is preferably a microwave ablation probe tip, and the microwave ablation probe tip may receive microwave energy from the ablation source as the ablation means. The microwave energy may be delivered to the targeted tissue via the ablation probe tip. The ablation source may provide microwave energy at frequencies ranging from 500 MHz to 300 GHz.

[0113] In one alternative of the fourth preferred ablation probe tip, the ablation probe tip is preferably a radiofrequency ablation probe tip.

[0114] Objectives, features, combinations, and advantages described and implied herein will be more readily understood upon consideration of the following detailed description of the invention, taken in conjunction with the accompanying drawings. The subject matter described herein is also particularly pointed out and distinctly claimed in the concluding portion of this specification.

DESCRIPTION OF THE DRAWINGS

[0115] The accompanying drawings illustrate various exemplary ablation probe systems, components of various exemplary ablation probe systems, and/or provide teachings by which the various exemplary ablation probe systems are more readily understood.

FIG. 1A is a simplified block diagram of an ablation probe system, a custom physical surgical stent, and a soft tissue ablation site.

FIG. 1B is a simplified display showing virtual surgical guide angle markings, a virtual stop marking, and virtual target markings guiding a representation of a sensed hand piece and ablation probe tip.

5 FIG. 2 is a simplified cross-sectional view of an exemplary soft tissue ablation site within an oral cavity, the ablation probe tip positioned by the stent such that the center of ablation is within the soft tissue.

FIG. 3 is a simplified cross-sectional view of an exemplary soft tissue ablation site within an oral cavity, the ablation probe tip positioned by the stent such that the center of ablation is within the soft tissue, radiating arrows representing an exemplary ablation zone.

10 FIG. 4 is a cross-sectional view of tissue having a "middle" with radiating arrows representing an exemplary ablation zone and the oval outline representing predetermined outer limits of the ablation zone.

FIG. 5 is a computed tomography (CT) cross-sectional image of an axial view of a tooth bud that shows the prescribed, desired or predetermined zone of ablation.

15 FIG. 6 is a CT cross-sectional image of a coronal view of a tooth bud that shows the prescribed, desired or predetermined zone of ablation.

FIG. 7 is a CT cross-sectional image of a sagittal view of a tooth bud that shows the prescribed, desired or predetermined zone of ablation.

FIG. 8 is a cross-sectional view of an ablation probe.

FIG. 9 is a cross-sectional view of an ablation probe and three different predetermined ablation zone shapes.

20 FIG. 10 is a cross-sectional view of an ablation probe and exemplary energy flow.

FIG. 11 is a cross-sectional view of an ablation probe and an oblate ablation zone.

FIG. 12 is a cross-sectional view of an ablation probe and a spherical ablation zone.

FIG. 13 is a cross-sectional view of an ablation probe and an oblong ablation zone.

25 FIG. 14A is a graphical representation of an ablation probe and an oblate (aspect ratio > 1.0) heating pattern that results in an oblate soft tissue ablation zone.

FIG. 14B is a graphical representation of an ablation probe and a spherical (aspect ratio = 1.0) heating pattern that results in a spherical soft tissue ablation zone.

FIG. 14C is a graphical representation of an ablation probe and an oblong (aspect ratio < 1.0) heating pattern that results in an oblong soft tissue ablation zone.

30 FIG. 15A is a photographic representation of an ablation probe and an oblate (aspect ratio > 1.0) heating pattern that results in an oblate soft tissue ablation zone.

FIG. 15B is a photographic representation of an ablation probe and a spherical (aspect ratio = 1.0) heating pattern that results in a spherical soft tissue ablation zone.

35 FIG. 15C is a photographic representation of an ablation probe and an oblong (aspect ratio < 1.0) heating pattern that results in an oblong soft tissue ablation zone.

FIG. 16A is a photographic representation that shows the adverse impact of using conventional medical ablation at 2.45 GHz that results in an oblong soft tissue ablation zone.

FIG. 16B is a photographic representation of that shows a zone of ablation produced at a higher frequency (8 GHz) that results in a tear-drop shaped soft tissue ablation zone.

40 FIG. 16C is a photographic representation of that shows a spherical zone of ablation generated using the tooth bud ablation probe described herein.

FIG. 17 shows the results of an exemplary probe experiment related to roundness at sixty degrees Celsius (60°C).

FIG. 18 shows the effects of power and time on the cross-sectional ablation zone area in an exemplary modeling that describes the volume of ablation.

45 FIG. 19 is a simplified view showing an ablation probe maintaining a stationary center of ablation with no asymmetrical migration of the ablation zone up the probe tip shaft.

FIG. 20A is a photographic representation of an ablation probe with the center of soft tissue ablation generating temperatures in excess of one hundred degrees Celsius (100°C), the steam generated as a result shown as the wavy inner rings near the probe.

50 FIG. 20B is a photographic representation of an ablation probe with the center of soft tissue ablation generating temperatures remaining below one hundred degrees Celsius (100°C), the rings being more regular since no steam is present.

FIG. 21 is a photographic representation that shows an under ablation-zone, a correct ablation zone, and an over-ablation zone.

55 FIG. 22 shows the results of an exemplary probe experiment correlating ablation zone diameter (in millimeters) to ablation duration (in seconds).

FIG. 23A is a graphical representation of an ablation probe with a short annular aperture (bounding a small focal region) and a short active heating zone that creates high power loading in the ablation zone.

FIG. 23B is a graphical representation of an ablation probe with a medium annular aperture (bounding a medium focal region) and a medium active heating zone that creates medium power loading in the ablation zone.

FIG. 23C is a graphical representation of an ablation probe with a long annular aperture (bounding a large focal region) and a long active heating zone that creates low power loading in the ablation zone.

5 FIG. 24A is a photographic representation of an ablation probe with a small focal region creating high power loading in the ablation zone.

FIG. 24B is a photographic representation of an ablation probe with a medium focal region creating medium power loading in the ablation zone.

10 FIG. 24C is a photographic representation of an ablation probe with a large focal region creating low power loading in the ablation zone.

FIG. 25 is a cross-sectional view of an ablation probe tip with exemplary active cooling.

FIG. 26A is a perspective side view of an ablation probe tip with a fluid thermal reservoir.

FIG. 26B is a side view of an ablation probe tip with a solid thermal reservoir.

FIG. 26C is a side view of an ablation probe tip with a solid thermal reservoir integrated handle.

15 FIG. 26D is a cross-sectional view of an ablation probe tip with a solid thermal reservoir taken along the thermal reservoir.

FIG. 27 is a cross-sectional view of the ablation probe of FIG. 26B during an experimental trial (run).

FIG. 28A is a graph showing the heat transfer layer "shunt effect" and, more specifically, the relationship of temperature to ablation energy duration for three different ablation probe tips.

20 FIG. 28B is a graph showing control of the ablation probe temperature and, more specifically, that the relationship of temperature over time does not exceed thirty-seven degrees Celsius (37°C) for three different ablation probe tips in which the thermal reservoir is chilled.

FIGS. 29A-29C is a continuous chart showing the heat transfer layer "shunt effect" in more detail.

25 FIG. 30A is a photographic representation showing the comparison of results of an ablation using a heat transfer layer (cooling shunt) that exceeded sixty degrees Celsius (60°C).

FIG. 30B is a photographic representation showing the comparison of results of an ablation using a heat transfer layer (cooling shunt) that did not exceed sixty degrees Celsius (60°C).

30 **[0116]** The drawing figures are not necessarily to scale. Certain features or components herein may be shown in somewhat schematic form and some details of conventional elements may not be shown or described in the interest of clarity and conciseness. For example, even though a tooth bud is shown, any soft tissue can be considered. The drawing figures are hereby incorporated in and constitute a part of this specification.

DETAILED DESCRIPTION

35 **[0117]** The present disclosure describes apparatuses, methods/procedures, and systems that generally relate to the technical field of medical ablation probes. Some of the preferred apparatuses, methods/procedures, and systems described herein specifically relate to the technical field of microwave ablation (MWA) and radiofrequency ablation (RFA) probes that deliver controlled zones of soft tissue ablation. Although the apparatuses, methods/procedures, and systems could be applied to any type of targeted tissue, tooth buds will be used as an exemplary targeted tissue throughout this document.

40 **[0118]** The ablation probe system (that may be or may be referred to as "tooth bud ablation technology" or "micro-ablation technology") described herein allows the operator to precisely control at least one or more intra-operative parameters to deliver predictable clinical outcomes. Specific intra-operative controls include:

- 45
- I. Volume scan imaging guided positioning control (that may be referred to as "ablation zone positioning control" or "positioning control");
 - II. Ablation zone shaping control (that may be referred to as "ablation zone shaping" or "shape ablation control");
 - III. Ablation center control (that may be referred to as "centering-directed ablation control");
 - 50 IV. Ablation zone temperature control (that may be referred to as "probe shaft maximum ablation temperature control" that includes "passive temperature control" and "active temperature control.");
 - V. Guided ablation volume/diameter control (that may be referred to as "ablation zone volume/diameter control"); and
 - VI. Power loading control (that may be referred to as "power density control").

55 Controlling various combinations of these controls and their respective parameters results in highly selective ablation of the targeted tissues while mitigating damage to immediately adjacent collateral tissues. Such control limits damage outside the targeted tissue in a shaped zone of ablation with a size that is prescribed for treatment. Additionally, controlling the various combinations of these controls substantially reduces or eliminates tissue damage along the shaft of the

ablation probe tip 100 that conventional ablation probes fail to limit. This ability to control the size and shape of the prescribed zone of ablation (while keeping the position at which the center of ablation stationary when ablating tissue) substantially eliminates unwanted tissue damage along the probe shaft is unique.

[0119] The ablation probe system, as described herein, may be implemented as surgical ablation kits (that may be referred to as "surgical kits," or "micro-ablation kits") that preferably contain a patient-specific ablation probe tip (that may or may not be disposable) and a patient-specific high precision surgical guide (that may be a physical disposable guide as shown in FIG. 1A or a virtual guide as shown in FIG. 1B) used to position the probe during ablation. The high precision surgical guide (whether physical or virtual) is preferably suitable for directing the ablation probe tip's center of ablation to within (and preferably the middle of) the targeted tissue. Surgical kits may also include a "prescription" that indicates ablation energy dose tolerances and settings (e.g. level of energy and duration of energy deliverance) that should result in ablation of the targeted or predetermined or prescribed volume of soft tissue. The ablation kits may include and/or be used with an ablation source (e.g. a "smart" ablation generator) and a hand piece.

[0120] The apparatuses, methods/procedures, and systems described herein produce zones of heating (ablation zones) that result in a predetermined volume of tissue hyperthermia in a predetermined position. This focal hyperthermia induces a selective zone of cell death due to localized thermocoagulative necrosis that leads to tooth agenesis when a sufficient volume of tooth bud tissue has been destroyed (i.e. not just killing the cells, but destroying the targeted or prescribed tissue in a predetermined fashion). The ablation, therefore, removes or destroys the predetermined targeted tissue while minimally damaging surrounding tissue or structure compared to more invasive conventional surgical techniques. Once the targeted tissue is destroyed, then the body's normal healing mechanisms will remove the destroyed tissue.

[0121] Live animal trials of tooth bud ablation using the apparatuses, methods/procedures, and systems described herein, have delivered microwave energy into the soft tissue at frequencies ranging from 500 MHz up to 300 GHz. Testing results in multiple live audited animal trials have shown a 100% success of ablating targeted tissue ablation zones and clinically inducing complete molar tooth agenesis with limited damage to adjacent non-targeted tissues when the prescribed or predetermined thermal dose has been delivered. Further, there is excellent healing with all dead tissue removed, complete infilling of the bone, and no sign of any tooth formation arising from the targeted tooth bud within 4-6 weeks following treatment. Testing results show that using the ablation probe system will allow dental practitioners to deliver twenty-to-forty (20-40) second micro-ablation tooth bud ablation treatments in a highly controlled fashion when at least one of the intra-operative controls of the ablation probe system is employed.

[0122] The ablation technology described herein is believed to be unique because it is the only known medical ablation process with the ability to concurrently control positioning, shape, centering, peak temperature, power loading, and volume and/or diameter of the targeted ablation tissue. This ablation technology is also believed to be unique because it can concurrently control the peak or maximum temperature along the shaft of the probe to eliminate unwanted tissue damage along the probe shaft.

[0123] There are many possible advantages of the preferred ablation probe systems 50 described herein. Some possible preferred advantages include, but are not limited to, the following advantages:

- Because of the heat transfer mechanisms, preferred ablation probe systems 50 can yield twenty-to-forty (20-40) second ablation times without overheating the tissue (and thereby avoiding tissue charring) with the possibility that longer ablation times can be used when lower power densities (power loading) are employed or when larger ablation volumes are prescribed.
- The energy dose delivered by preferred ablation probe systems 50 can be monitored and controlled for repeatability over a wide range of clinical conditions and operator skills.
- Preferred ablation probe systems 50 have ablation probe tips 100 (that may be referred to as probe tips 100, micro-ablation probe tips 100, and micro-ablation ablation probe tips 100) with shafts having a diameter of 3.8 mm (the diameter of a 7-gauge needle) down to 1.0 mm or less (the diameter of a 20-gauge needle) for applications that require such small dimensions. However, larger diameter probes with more cross-sectional area in the heat transfer layer 130 can be used to deliver high levels of energy or in longer duration procedures.
- Because the ablation probe's center of ablation 124 (focal region 124) is stationary (the center of ablation 124 does not migrate during treatment), predetermining the outer margins of the ablation zone 150, 160, 170 to encompass only targeted tissues (e.g. at least part of a tooth bud 92 or any other targeted soft tissue) becomes significantly more predictable while reducing the risk of ablating surrounding tissue.
- The center of ablation 124 (focal region 124) is predetermined and, because it is stationary, its location remains known and fixed during the entire ablation cycle. The location of the active heating zone 125 surrounding the focal region 124 (and the tissue peak temperatures of the active heating zone 125), therefore, are significantly more predictable. When operating with a known power input the predictability of the active heating zone 125 at least reduces (and possibly eliminates) tissue "charring" into a black, undefined mass which, in turn, reduces (and possibly

eliminates) the risk of adverse post-operative healing (such as scarring).

- Because the maximum or peak temperature along the shaft can be predetermined for any given ablation procedure, the ablation probe tip 100 has the ability to deliver the prescribed or predetermined ablation energy dose without damaging non-targeted tissues along the shaft. This means the operator does not have to be concerned with preventing burning, charring, or damaging critical tissues (e.g. epidermal or mucosal tissues) along the shaft at the probe insertion site or that come in contact with the probe along the probe insertion pathway. If such non-targeted tissues were burned or charred, then these non-targeted tissues become avascular and result in increased rates of infection due to bacteria present on the surface of epidermal and mucosal tissues that line the mouth, GI tract, or respiratory pathway that are critical for keeping bacteria out of the body. Additionally, epidermal and mucosal tissue alike have numerous pain receptors that - if unnecessarily ablated - result in increased post-ablation pain that can be prevented using ablation probes described herein.

[0124] Before describing the ablation apparatuses, methods/procedures, and systems and the figures, some of the terminology should be clarified. Please note that the terms and phrases may have additional definitions and/or examples throughout the specification. Where otherwise not specifically defined, words, phrases, and acronyms are given their ordinary meaning in the art. The following paragraphs provide basic parameters for interpreting terms and phrases used herein.

- The term "tissue" is meant to describe any of the distinct types of material of which people or animals are made, consisting of specialized cells and their products. The tissue may be soft tissue such as epidermal tissue (skin), mucosal tissue (that lines the nose and mouth and entire GI tract and respiratory tract), blood vessels, organs (e.g. the liver, stomach, spleen, pancreas, and brain), or parts thereof. The tissue may also be hard tissue (e.g. bone, teeth, or parts thereof) that have living cells in them that are heat sensitive. The phrase "targeted tissue" (that may be referred to as "target tissue") is meant to describe the tissue that is desired, predetermined, or prescribed to be ablated. Exemplary targeted tissue might be a tooth bud, a tumor, or a part of a bone with cancerous tissue within the matrix of the bone. While the examples herein are focused on tooth buds as the targeted tissue, it should be understood that other types of tissues could be targeted tissues. The phrase "surrounding tissue" is meant to describe the tissue surrounding the targeted tissue that should not be ablated.
- The term "middle" (used in the phrases "middle of the tooth bud" or "middle of the tissue") is meant to describe a position within the targeted tissue (e.g. a tooth bud or a tumor). The middle is not necessarily the absolute "middle" of the tissue. A "calculated middle" of the tissue to be ablated may be calculated by methods including, but not limited to, those using volume, three-dimensional position, and/or other known or yet to be discovered methods. A "predetermined middle" (or "predetermined position") may be the "calculated middle" of the tissue to be ablated or it may just be a known position within the tissue to be ablated. Unless specifically noted otherwise, where the "middle" is discussed, a calculated and/or predetermined middle within the tissue may be used.
- The phrase "ablation zone" (that may be referred to as "zone of soft tissue ablation," "controlled zone of soft tissue ablation," "zone of ablation," "zone of heating," and "zone of temperature control") is meant to describe the area in which ablation will be created or has been created. Ideally, the ablation zone is substantially coextensive with the targeted tissue. The targeted tissue can also be thought of as the target ablation zone. The ablation zone has a three-dimensional area or volume even though photos and drawings herein may render them to appear as a two-dimensional image.
- The term "micro-ablation" is meant to describe ablations that are smaller than 25.0 mm in diameter for use on smaller anatomical structures, such as a tooth bud, although they can be larger and used on tumors that exceed 5.0 cm in diameter. For micro-ablations, the probe tip 100 would be a micro-ablation probe tip. Unless specified otherwise, the phrase "probe tip" will include micro-ablation probe tips or tips that are intended for larger ablations.
- The phrase "ablation means" (as in ablation means 62) is meant to describe the mechanism (e.g. energy) by which ablation or micro-ablation is performed. Preferred ablation means may be energy such as microwave (MW) and/or radiofrequency (RF) and, in particular, microwave ablation energy in the range of 500 MHz to 300 GHz (broad spectrum) and radiofrequency ablation energy in the range of 100 MHz to 500 MHz. Frequencies above and below these levels may be appropriate for particular uses. The ablation means 62 is provided by an ablation source 60.
- The phrase "ablation source" (as in ablation source 60) is meant to describe the mechanism by which the ablation means is produced. The ablation source 60 may be a purpose-built ablation source such as a "smart" ablation generator. The ablation source may be a generator and/or an amplifier (jointly referred to as a generator). If the ablation means 62 is microwave ablation means, the ablation source 60 may be a microwave generator. If the ablation means 62 is radiofrequency ablation means, the ablation source 60 may be a radiofrequency generator. If the ablation source 60 is a "smart" generator it may be loaded with the procedure parameters (e.g. time, temperature, rate of energy delivered, frequency, and other parameters) that can then deliver the ablation means based on those parameters to the targeted tissue. A smart generator may have error checking and safety measures. For example,

a smart generator can monitor for bad probe tips 100 by measuring forward power/energy and reflected power/energy to measure the total power/energy (energy/time) being delivered into the ablation zone. If the smart generator cannot reach the prescribed energy level and/or cannot maintain the prescribed energy level, then the procedure is stopped and an error message is generated instead of delivering an energy dose that is other than the prescribed or pre-determined amount.

- The phrases "center of ablation" and "focal region" are meant to describe the portion of the inner conductor 112 that is bounded by the annular aperture 120 from which the ablation means 62 radiates. An active heating zone 125 surrounds the focal region 124. Surrounding the active heating zone 125 is an ablation zone 150, 160, 170. As shown in FIGS. 23A-23C, for example, the area of the ablation zone 160a, 160b, 160c (which are variations of the spherical ablation zone 160) beyond the active heating zone 125 is a thermal heating zone 126 (created by thermal conduction).
- The phrases "active heating zone," "tissue active heating zone," "tissue zone of active heating," "zone of active heating," "active zone of heating," and variations thereof are meant to describe the targeted tissue within the ablation zone 150, 160, 170 that the ablation means 62 initially enters. As shown in FIGS. 23A-23C, for example, the active heating zone 125 is at least substantially annularly adjacent to annular aperture 120 of the probe tip 100. The active heating zone 125 is where the radiative energy is converted from radiative energy to thermal energy. The tissue within the ablation zone 150, 160, 170 that is located outside of the active heating zone 125 (i.e. within the thermal heating zone 126) still incurs cell death, but cell death within the thermal heating zone 126 is caused by heat conducting outwards from the active heating zone 125.
- The phrases "power loading," "power density," "power loading density," and "volume power density" describe the amount of energy (e.g. microwave or radiofrequency energy) as a function of time (power being a unit of energy being delivered per unit of time) being delivered into the active heating zone 125. For example, a dipole antenna (a longer and lower power loading antenna) with no end load and a lower capacitive coupling will generally be two to four times longer than the shown shorter and higher power loading end-loaded antenna (e.g. an ablation probe tip 100 having an end load 122). In this example, microwave energy spreads over the longer antenna in a predefined fashion before radiating outwards into the active heating zone 125. The spread of the energy in the longer antenna results in a power loading density in the active heating zone 125 that is two to four times lower when compared to the higher power loading in the shorter antenna delivering the same amount of energy per unit of time.
- The term "profile" (as used in the phrases "ablation zone profile," "probe profile," "ablation profile," "probe ablation profile," and "ablation zone margins" or "ablation zone tissue margins" is meant to describe the known attributes and variables of the ablation zone associated with a particular ablation probe system 50 and/or the ablation zones 150, 160, 170 it produces in soft tissues. These attributes and variables include, but are not limited to, the shape (e.g. oblate, spherical, oblong) of the ablation zone the ablation probe system 50 produces, the size (e.g. dimensions and volume) of the ablation zone the ablation probe system 50 produces, the location of the ablation zone along the length of the probe tip 100, the temperature of the ablation zone the ablation probe system 50 produces, and the time (duration) it takes the ablation probe system 50 to produce the ablation zone. The attributes and variables may be interrelated with each other. For example, the size of the ablation zone the ablation probe system 50 produces may be directly related to how much ablation means 62 (e.g. microwave energy) is used and how long the ablation means 62 is used. Using an ablation probe system 50 having the appropriate profile with the appropriate input for the appropriate duration will produce the desired ablation zones 150, 160, 170.
- The phrase "thermal transfer rate" (as well as the phrases such as "heat transfer rate," "thermal conductance," "thermal conductivity rate," "thermal conductive rate," and "thermal conduction rate") is meant to describe the rate (or amount of heat/time) that a material can transfer heat as a result of its size, cross-sectional area, thermal capacitance, and other properties of the material itself.
- The phrase "thermal capacitance" (as well as the phrase "thermal volume") is meant is meant to describe the total heat energy volume a material can hold.
- The phrase "volume scan" (as well as the phrase "volume scanning" and other variations used herein) is meant to include any volume scanning technology known or yet to be discovered that at least relatively safely accurately generates the necessary multi-dimensional images that can be used in medical procedures. Exemplary volume scan imaging includes, but is not limited to, computed tomography (CT) (e.g. cone beam computed tomography (CBCT)), X-ray, magnetic resonance imaging (MRI), ultrasound, nuclear medicine imaging (e.g. positron-emission tomography (PET)), and other types of volume scan imaging or three-dimensional soft tissue imaging that may be used or be adapted to be used to implement the functions described herein. The phrase and variations thereof may be used as a noun (e.g. the image) or a verb (the process of taking the image). Whether the phrase is used as a noun or a verb can be determined from the context in which it is used.
- The term "image" is meant to describe both the process of taking a "picture" and the "picture" itself, the difference therebetween apparent from context. The "picture" may be a volume scan image such as a cone-beam image (produced, for example, by a computed tomography (CT) image (e.g. cone beam computed tomography (CBCT)

image), an X-ray image, a magnetic resonance imaging (MRI) image, an ultrasound image, a nuclear medicine image (e.g. a positron-emission tomography (PET) image), or any image means known or yet to be discovered that can show the targeted tissue and surrounding tissue in sufficient detail to allow the system and methods described herein to be used. In some instances, a specific type of imaging is suggested, but other imaging may be used if it may accomplish the same purpose. For example, panoramic imaging is suggested for routine screening for tooth buds, but other types of imaging known or yet to be discovered could be used to screen for tooth buds and measure tooth bud soft tissue dimensions. When used as a verb, the term "image" is the process of taking an "image" as described above.

- Electromagnetic fields around objects such as antennas can be divided into regions including "near field" (which can additionally be divided into non-radiative (reactive) and radiative (fresnel)) and "far field." Non-radiative "near field" behaviors dominate close to the antenna, while "far field" behaviors dominate at greater distances in which full wave forms occur after they leave the near field region. In near field regions, there is interference with the propagation of electromagnetic waves and, therefore, the near field regions are considered unpredictable for allowing coherent waveforms to occur. By contrast, in far field regions, the field acts as "normal" with a relatively uniform or coherent wave pattern. Ablation probe systems 50 described herein are preferably designed to function in the near field region.
- The ablation system described herein may have associated hardware, software, and/or firmware (a variation, subset, or hybrid of hardware and/or software). The term "hardware" includes at least one "processing unit," "processor," "computer," "programmable apparatus," and/or other known or yet to be discovered devices capable of executing instructions or steps. The term "software" includes at least one "program," "subprogram," "series of instructions," or other known or yet to be discovered hardware instructions or hardware-readable program code. Exemplary software includes the surgical stent design software suite described herein. Software may be loaded onto hardware (e.g. the ablation source 60) to produce a machine, such that the software executes on the hardware to create structures for implementing the functions described herein. Further, the software may be loaded onto the hardware (e.g. the ablation source 60) to direct the ablation probe system 50 to function in a particular manner described herein or to perform a series of operational steps as described herein. The phrase "loaded onto the hardware" also includes being loaded into memory associated with or accessible by the hardware (including firmware). The term "memory" (e.g. the memory of the ablation source 60) is defined to include any type of hardware (or other technology)-readable media (that may be referred to as a machine-readable storage medium) including, but not limited to, attached storage media (e.g. hard disk drives, network disk drives, servers), internal storage media (e.g. RAM, ROM, EPROM, FLASH-EPROM, or any other memory chip or cartridge), removable storage media (e.g. CDs, DVDs, flash drives, memory cards, floppy disks, flexible disks), firmware, and/or other known or yet to be discovered storage media. Depending on its purpose, the memory may be transitory and/or non-transitory. Appropriate "communications," "signals," and/or "transmissions" (which include various types of information and/or instructions including, but not limited to, data, commands, bits, symbols, voltages, currents, electromagnetic waves, magnetic fields or particles, optical fields or particles, and/or any combination thereof) over appropriate "communication paths," "transmission paths," and other means for signal transmission including any type of connection between two elements of the system (the system including, for example, the ablation source 60, the hand piece 52, the ablation probe tip 100, other hardware systems and/or subsystems, and/or memory) would be used as appropriate to facilitate controls and communications.
- The term "associated" (and variations such as "associable"), when used in the context of a connection between components, is defined to mean integral or original, retrofitted, attached, connected (including functionally connected), positioned near, and/or accessible by. For example, if a display (such as the output mechanism 68 or other component) is associated with a computer (including a processor associated with the ablation source 60 or other technology), the display may be an original display built into the computer, a display that has been retrofitted into the computer, an attached display that is attached to the computer, a nearby display that is positioned near the computer, and/or a display that is accessible by the computer. Another example is that the connection between the ablation source 60, the hand piece 52, and the ablation probe tip 100 are described as associable in that the connections between these items may be integral or original, retrofitted, attached, connected (including functionally connected), positioned near, and/or accessible by.
- The terms "may," "might," "can," and "could" are used to indicate alternatives and optional features and only should be construed as a limitation if specifically included in the claims. It should be noted that the various components, features, steps, designs, or embodiments thereof are all "preferred" whether or not it is specifically indicated. Claims not including a specific limitation should not be construed to include that limitation.
- Unless specifically stated otherwise, the term "exemplary" is meant to indicate an example, representation, and/or illustration of a type. The term "exemplary" does not necessarily mean the best or most desired of the type.
- It should be noted that, unless otherwise specified, the term "or" is used in its nonexclusive form (e.g. "A or B" includes, but is not limited to, A, B, A and B, or any combination thereof). It should be noted that, unless otherwise

specified, "and/or" is used similarly (e.g. "A and/or B" includes, but is not limited to, A, B, A and B, or any combination thereof). It should be noted that, unless otherwise specified, the terms "includes," "has," and "contains" (and variations of these terms) mean "comprises" (e.g. a device that "includes," "has," or "contains" A and B, comprises A and B, but optionally may contain C or additional components other than A and B).

- It should be noted that, unless otherwise specified, the singular forms "a," "an," and "the" refer to one or more than one, unless the context clearly dictates otherwise. Similarly, unless specifically limited, the use of singular language (e.g. "component," "module," or "step") may include plurals (e.g. "components," "modules," or "steps"), unless the context clearly dictates otherwise.

I. Volume Scan Guided Positioning and Ablation Control

[0125] Volume scan, as described herein is any scanning technology that at least relatively safely can accurately generate the necessary multi-dimensional images that can be used in ablation procedures. "Volume scan guided positioning and ablation control" may also be referred to as "volume scan guided control" and "volume scan guided procedures." "Volume scan guided positioning and ablation control" includes "volume scan guided positioning control," "volume scan guided ablation control," and "volume scan guided soft tissue ablation." Volume scan guided control is a technology for precisely positioning an ablation probe tip and then ablating the desired soft tissue by delivering the predetermined amount of energy based upon the soft tissue dimensions measured in the volume scan. Positioning may be accomplished by physically using a physical stent as shown in FIG. 1A) and/or virtually using a virtual stent as shown in FIG. 1B).

[0126] Ablating may be accomplished by heating a predetermined soft tissue volume by controlling the energy delivery. Such physical and virtual stents are described in the Therapeutic Tooth Bud Ablation Properties. For example, the creation of a custom surgical stent using location and measurement information about the tooth bud obtained from a scan is described in the Therapeutic Tooth Bud Ablation Properties as well as herein. To control the tissue volumes being ablated, tissue dimensions are obtained from volume scans and a predetermined amount of tissue to be ablated is prescribed to effect desired treatment.

[0127] Volume scan guided positioning control (e.g. a physical stent or virtual stent) may be created from preoperative measurements obtained using volume scan technology. Exemplary steps for creating a stent include, but are not limited to:

- Selecting an ablation probe tip (that may be a sensed ablation probe tip) with known dimensions and capabilities. Information about the dimensions and capabilities may be stored in a volume scan information technology file (e.g. a three-dimensional computer aided design (CAD) file).
- Using volume scanning technology, scanning a patient's mouth. Information (including a volume scan image) from the volume scan may be stored in a scanning technology file (e.g. the volume scan information technology file).
- From the volume scan, creating physical (traditional) or digital impressions of the patient's teeth and gum tissue (gingival tissue). If a digital impression is created, it may be stored in a volume scan information technology file.
- From the volume scan or information in the volume scan information technology file, obtaining (e.g. calculating and/or measuring) the tooth bud size and position using information in the volume scan information technology file. Information about the tooth bud size and position may be stored in a volume scan information technology file.
- From the volume scan or information in the volume scan information technology file, locating a landmark (e.g. the distal side of erupted first molars or soft tissue over bone). Information about the location of the landmark in relation to the tooth bud may be stored in a volume scan information technology file.
- From the volume scan or information in the volume scan information technology file, locating or obtaining (e.g. calculating and/or measuring) the middle of the tooth bud (calculated middle) or at least a position within the tooth bud (a predetermined position). Information about the middle of the tooth bud may be stored in a scanning technology file.
- From the volume scan or information in the volume scan information technology file, obtaining (e.g. calculating and/or measuring) a predetermined angle (the angle at which the ablation probe tip's effective center of ablation is in the middle of the tooth bud - shown as 90 degrees in FIG. 2) to guide the ablation probe tip. The angle could be calculated/measured from a known point (e.g. the landmark or the point of entry - taking into consideration the thickness and surface of a physical stent and the shape of the ablation probe tip) to the middle of the tooth bud. Information about the predetermined angle may be stored in a scanning technology file.
- From the volume scan or information in the volume scan information technology file, obtaining (e.g. calculating and/or measuring) predetermined depth (the depth at which the ablation probe tip's effective center of ablation is in the middle of the tooth bud) to limit the depth of the ablation probe tip. The depth could be calculated/measured from a known point (e.g. the landmark or the point of entry - taking into consideration the thickness and surface of a physical stent and the shape of the ablation probe tip) to the middle of the tooth bud. In FIG. 2, the depth D is shown as the distance between the upper surface of the gingival tissue and the center of ablation or, alternatively, the depth D + D' is shown as the distance between the upper surface of the stent and the center of ablation. If there

was a raised mechanical stop (as shown in FIG. 1A), its height could also be added to the depth. Information about the predetermined depth may be stored in a scanning technology file.

- Processing the information in the volume scanning technology file(s) (that may be one file or multiple files) to put the information into a form that can be used for creating or manufacturing a stent (physical or virtual) and to create a "prescription" that indicates ablation energy dose tolerances and settings (e.g. level of energy and duration of energy deliverance) in order to be guided in selectively ablating the targeted tissues. "Creating" includes "manufacturing" such that both the virtual stent and the physical stent are created, but only the physical stent is manufactured. Depending on what is being "created," "creating" (and variations thereof) may also include programming, gathering, or other ways of bringing into existence.
- Creating or manufacturing a stent (virtual or physical) with at least one surgical guide (virtual or physical) to guide the ablation probe tip at the predetermined angle and at least one stop structure (virtual or physical) to limit the depth of the ablation probe tip to the predetermined depth. If the stent is physical, it may have mechanical stop structure that interacts with the stent's mechanical stop structure.

Using the stent surgical guide and mechanical stop structure, the ablation probe tip may be guided such that said center of ablation is within said tooth bud (and, preferably, at the middle of the tooth bud) when the ablation probe tip is guided at said predetermined angle to said predetermined depth.

[0128] FIGS. 1A, 1B, 2, and 3 show a basic system that uses volume scan guided positioning controls (shown as a physical stent 80 or a virtual stent 82', 86', 88') to properly position ablation probe systems 50 (including the probe tip 100) that deliver shaped, centered, temperature controlled, and/or volume controlled targeted tissue ablation. Volume scan guided procedures accurately position the ablation probe tip 100 to assure that the tooth bud tissue will be warmed from within (including from the middle of) the tooth bud outwards to a predetermined volume with outer soft tissue ablation margins in their desired location. Doing so results in safe and effective tooth bud ablation while mitigating damage to adjacent collateral tissues next to the tooth bud. As previously stated, this predetermined or prescribed volume applies to other forms of tissue ablation besides tooth bud tissues. There is no known competing technology that has this level of accuracy for three-dimensional (3D) positioning of the zone of ablation and delivering the predetermined ablation zone in the predetermined position throughout the procedure.

[0129] Although some exemplary ablation probe system(s) 50 and components thereof are described in more detail herein, FIGS. 1A, 1B, 2, and 3 provide a broad overview of an exemplary ablation probe system 50 as it is used in an exemplary application (tooth bud ablation). The ablation probe system 50 may work in conjunction with a custom surgical stent (the physical stent 80 shown in FIG. 1A or the virtual stent 82', 86', 88' shown in FIG. 1B) at a tooth bud ablation site 90. Robotics (which includes full robotic control or robotic assisted procedures) could also be used in volume scan guided soft tissue ablation, the robotics being a form of guidance that may be used with either the physical system or the virtual system. Some exemplary physical guides and virtual guides are described in the Therapeutic Tooth Bud Ablation Properties. For other non-tooth bud procedures, where the ablation site could be a site (location on a body) covering any targeted tissue, an appropriate surgical stent could be used to guide placement of the probe tip. For example, if the tumor were on a leg, a physical or virtual stent appropriate to a leg would be used.

[0130] As shown in FIG. 1A, an ablation probe system 50 (or ablation probe 50) includes an ablation probe tip 100, a hand piece 52, and an ablation source 60 which provides and/or facilitates the provision of an ablation means 62. The ablation probe tip 100 may be integral or connectable (directly or indirectly) or otherwise associable with the hand piece 52. The hand piece 52 may be integral or connectable (directly or indirectly) or otherwise associable with the ablation source 60. The hand piece 52 may be autoclavable. One type of indirect connection could include the use of a wire or cable that functionally connects components. Another type of indirect connection could include remote control mechanisms (e.g. appropriate transmitters and receivers) that functionally connect components.

[0131] FIGS. 1A, 2, and 3 show volume scan guided positioning control implemented as a custom surgical stent 80 having at least one surgical guide 82 (shown as darkened solid lines through the surgical stent 80 in FIG. 1A) and a stent mechanical stop 86 (which, as shown in FIG. 1A, may be a raised portion of the stent 80 at least relatively adjacent to the surgical guide 82 or, as shown in FIGS. 2-3, just the upper surface of the stent 80 at least relatively adjacent to the surgical guide 82). The stent 80, guide 82, and stop 86 together are a form of volume scan guided positioning control created using the process described herein. FIGS. 2-3 show that at least part of the surgical stent 80 may be at least partially supported by at least one erupted tooth. The custom surgical stent 80 is positioned so that a surgical guide 82 covers and/or surrounds the tooth bud 92 at the tooth bud ablation site 90 (including gingival tissue 94 and bone 96 (including the dense cortical bone)). FIG. 4 shows tissue (e.g. a tooth bud) having a middle 93 with radiating arrows that represent an exemplary ablation zone and the oval outline that represents predetermined or prescribed outer limits 98 of the ablation zone.

[0132] The ablation probe tip 100 (shown in FIG. 1A with solid lines before insertion and dashed lines after insertion) has a tip mechanical stop 106 and a center of ablation 124. The ablation probe tip 100 is insertable through gingival tissue 94 and into the tooth bud 92 (which is located within the bone 96 of a jaw). The ablation probe tip 100 is guided

by the stent 80 so that its insertion end 104 and center of ablation 124 would be within (e.g. at or near the middle 93 of) the tooth bud 92. The interaction between the surgical guide 82 and the tip shaft 102 guides the ablation probe tip 100 at the correct angle (shown as a 90 degree or straight angle, but could be other angles) so that the center of ablation 124 is within or at the planned position of tooth bud 92. More specifically, the interior diameter of the surgical guide 82 is just slightly larger than the outer diameter of the tip shaft 102 such that the ablation probe tip 100 inserted into the surgical guide 82 can only be inserted at the angle dictated (prescribed) by the surgical guide 82. Limiting the ablation probe tip 100 to the correct depth so that the center of ablation 124 is within the tooth bud 92 may be accomplished, for example, by the interaction between the stent mechanical stop 86 and the tip mechanical stop 106 (which may be, for example, a raised surface (FIG. 1A), an angled surface, and/or the top surface (FIGS. 2-3) of the stent 80). Preferably the center of ablation 124 is positioned at least substantially in the middle (e.g. calculated middle) of the tooth bud 92 as determined by volume, three-dimensional position, and/or other known or yet to be discovered methods. (The calculated or predetermined middle of the tissue to be ablated is the "middle of the tooth bud" 93.) The ablation probe tip 100 is positioned before the ablation means 62 is activated to create the ablation zones 150, 160, 170 (the radiating arrows - although only a single type of zone is shown in these figures, it is representative of differently shaped zones shown and discussed herein in relation to FIGS. 9 and 11-13). As shown in FIG. 3, the predetermined outer limits 98 of the ablation zone are preferably +/- 0.5 mm within the bony crypt of the tooth bud 92, but larger tolerances may be acceptable for treating other tissue types.

[0133] FIG. 1B shows a virtual stent system (82', 86', 88') that can be used with a sensed ablation probe tip 100' and/or a sensed hand piece 52'. The virtual stent may be dynamic navigation technology that is implemented as at least one software program (or subprogram) associated with the ablation source 60. The program would be able to receive input (e.g. the prescription) and convert the input to a virtual stent. Although the virtual stent could be used by itself, it could also be used in conjunction with a physical stent. For example, it could provide advanced notice as to approaching parameters (e.g. an audible "the tip is approaching the stop") or confirmation (e.g. a light flash on the handle or a pleasant audible "ding" when the probe tip is in position). Another example is that the surgical guide could be implemented physically, but the stop and/or target could be implemented virtually.

[0134] The virtual stent system could be shown on a visual display 68' with surgical guide angle markings 82', a virtual stop marking 86', and virtual target markings 88' overlaying an image (e.g. a volume scan) of the area 92' (e.g. tooth bud) to be ablated (for clarity, the actual image has been omitted). Although shown as lines (e.g. dashed lines), alternative visual position indicators could be a digital readout or color coding. The virtual surgical guide angle markings 82' are based on the three-dimensional path of insertion (defined by the predetermined angle (e.g. the 90 degree angle shown in FIG. 2) and predetermined depth (e.g. the depth D shown in FIG. 2)). In preferred embodiments, the system would not be able to be activated if the center of ablation was not in proper relationship to the middle of the tooth bud.

[0135] In addition to or in conjunction with a physical stent 80 and a virtual stent displayed on a visual display 68, alternative audible, visual, and/or tactile indications can be used as a surgical guide, stop, and/or target. For example, signals (e.g. an audible series of beeps, a series of flashing lights, or physical vibrations) could be used to indicate the probe tip is getting closer to the ablation zone. For example, the beeps/flashes/vibrations could get louder/brighter/faster as the probe tip approaches the ablation zone. Alternatively, the indicators could be a voice speaking the instructions (e.g. "3.0 mm ... 2.0 mm ... 1.0 mm) or the light could be color-coded (e.g. red to green). Another example is that the virtual stop and/or virtual target could be implemented audibly, visually, and/or tactilely using similar or different indicators. In robotic procedures (whether fully controlled robotic or robotic assisted), physical feedback to the operator may occur. Such physical feedback may include stopping the physical advancement of the probe by the robotic control system or actively shaking or vibrating the operator controls to alert the operator for additional procedure input before allowing the procedure to continue any further.

[0136] In use, the sensed ablation probe tip 100' may be guided by the virtual surgical guide angle markings 82' and the virtual stop marking 86' to a position in which the effective center of ablation 124' of the ablation probe tip 100' is in the middle of the tooth bud 93'. The operator may watch the insertion process on the display 68' as he physically manipulates the sensed ablation probe tip 100'. The virtual target markings 88' may also provide an indication that the sensed ablation probe tip 100' is within approximately 50%, 25%, and 10% of the average diameter of the tooth bud 92'. If the operator were manually manipulating the sensed ablation probe tip 100', the system would monitor the progress and alert the operator that the ablation probe tip 100' is not at the proper position using, for example, visual indicators, audible indicators, tactile indicators, or a combination thereof. Alternatively, the operator may monitor the progress on the display 68' as the sensed ablation probe tip 100' is inserted automatically (e.g. using a robotics system). Monitoring and override safeguards are preferably included in the system. For example, the system would not activate if the center of ablation was not in proper relationship to the middle of the tooth bud regardless of whether the insertion was performed manually or robotically.

[0137] When the probe tip 100 is properly positioned, the center of ablation 124 is within the tooth bud 92 at its predetermined position. Activating the ablation means 62 creates an ablation zones 150, 160, 170 (e.g. for a spherical tooth bud 92 (FIG. 1A) the appropriate ablation zone would be a spherical ablation zone 160, but for an oblate tooth bud

92 (FIGS. 2-3) the appropriate ablation zone would be an oblate ablation zone 150 centered about the center of ablation 124 within the tooth bud 92. If the ablation source 60 is a microwave generator, the ablation means 62 would be microwave energy. Ablation source parameter settings 64 and treatment time settings 66 may be provided by loading digital data (e.g. downloading parameter settings 64 and/or treatment time settings 66 using a provided "patient identification key" entered at a provided website address), by a user manually entering the data, or through some other data entry system such as scanning a 1D or 2D bar code or through the wireless transfer of data via an RFID chip.

[0138] Feedback from the ablation source 60 or from the ablation probe tip 100 (which may have at least one sensor 108 along the shaft 102 to monitor, for example, temperature) may be provided to the user (or to electronic or digital monitoring systems that may be implemented by software associated with an ablation source 60 (e.g. a smart generator)) using an output mechanism 68 such as a video display or audio display (speaker).

[0139] The volume scan (in this case a cone beam computed tomography (CBCT) volume scan) cross-sectional images in FIGS. 5-7 show the planned center-positioning of the ablation probe tip 100 inside a mandibular tooth bud (circled in dashed lines) of a pig (similar images could be taken of a human tooth bud). More specifically, FIG. 5 shows the axial view of a tooth bud, FIG. 6 shows the coronal view of a tooth bud, and FIG. 7 shows the sagittal view of a tooth bud.

[0140] It should be noted that the components of FIG. 1A are not to scale (for example, the ablation probe tip 100 would most likely be much smaller than the hand piece 52).

II. Ablation Zone Shaping Control

[0141] Another ablation probe system capability described herein is "ablation zone shaping" (or "ablation zone shaping control") inside the bony crypt of the tooth or any other targeted tissue type. FIGS. 8-18 detail how knowing at least one profile of ablation zones 150, 160, 170 and/or the ablation probe systems 50 (and their method of use) allows the selection of the specific ablation probe tips 100 to create predetermined ablation zones that are shaped and/or sized to correspond with targeted tissue ablation zones. More specifically, FIGS. 8-13 show cross-sections of exemplary probe tips using a tip with an antenna load 122 present. Other types of antenna designs, such as a dipole antenna that is 2-4 times longer, can also be used with similar results. FIGS. 14A-C show graphical representations of ablation probes and their respective ablation zones. FIGS. 15A-C show photographic representations of ablation probes and their respective ablation zones. FIGS. 16A-C show photographic representations of actual ablations that are oblong, tear-drop, and spherical ablations. FIG. 17 shows the results of an exemplary probe experiment and resulting zone of ablation related to roundness. The graph in FIG. 17 shows that oblate (width/length > 1), spherical (width/length = 1) and oblong (width/length < 1) can be controlled by increasing or decreasing the thermal conductivity for a fixed heat transfer layer 130 diameter.

[0142] FIGS. 8-13 show exemplary ablation probe tips 100 (including probe tips 100a, 100b, 100c) that are able to create ablation zones 150, 160, 170 with predetermined "shapes" and/or "sizes." For example, an ablation probe profile may specify a specific shape such as:

- oblate (the longest axis of ablation zone 150 being perpendicular to the shaft 102 of the ablation probe tip 100a) as shown in FIG. 11, having a width/length aspect ratio of greater than 1.0 (the oblate ablation zones 150 being wider than they are long);
- spherical as shown in FIG. 12 having a width/length aspect ratio of 1.0 (the spherical ablation zones 160 being as narrow as they are long); and/or
- oblong (the longest axis of ablation zone 170 being parallel and substantially coexistent with the shaft 102 of the ablation probe tip 100c) as shown in FIG. 13 having a width/length aspect ratio of less than 1.0 (the oblong ablation zones 170 being narrower than they are long).

Known microwave ablation probes produce oblong ablation zones that are narrower than they are long (an aspect ratio of less than 1.0) with some having an width/length ratio of less than 0.2. These known oblong ablation zones can be so long they may appear to be "hot dog" shaped along the probe. The oblong ablation zones of known microwave ablation probes are at least similar to the oblong ablation zones 170 (FIG. 13) produced by ablation probe systems 50 (those used with probe tip 100c).

[0143] Conventional medical microwave ablation (MWA) and radiofrequency ablation (RFA) are well understood methods of inducing tissue heating that results in thermocoagulation or coagulative necrosis (cell death). Known MWA and RFA, however, generate oblong-shaped zones of ablation relative to the position of the insertion path of the ablation probe. As a result, conventional medical ablation technology was found to be suboptimal for many tooth bud ablations because the zone of ablation procedure by conventional medical ablation systems did not destroy the tooth bud tissue without also unnecessarily destroying adjacent non-tooth bud tissue. If an ablation zone of the wrong shape is used, it is almost impossible to deliver the correct amount of ablation means without unnecessarily destroying on-tooth bud tissue. For example, if the tooth bud is spherical and the ablation zone is oblong, either too much tissue will be ablated (tissue outside the tooth bud will be ablated) which will damage surrounding tissue. Conversely, if the energy dose is

turned down to reduce tissue damage outside the tooth bud, then too little tissue inside the tooth bud will be ablated, which may result in an unsuccessful ablation. Put another way, unlike conventional medical ablation technology, the tooth bud ablation system described herein utilizes a proprietary ablation zone shaping technology for a more optimized fit inside the tooth bud that more selectively destroys targeted tooth bud tissue while destroying significantly less non-targeted tissue. Doing so greatly reduces the potential for collateral tissue damage, thus reducing the risk of adverse side effects.

[0144] FIGS. 14A-14C and FIGS. 15A-15C show representations of the heating patterns that result in the shaped ablation zones. Both the drawings of FIGS. 14A-14C and the photographs of FIGS. 15A-15C show a plurality of "isotherms" represented as a series of relatively annular lines (which can be thought of as nested rings) emanating from a relatively central region or point (an annular aperture 120 and/or a center of ablation 124 bounded by the annular aperture 120) of the tip shaft 102. Each of these isotherms represent ten degrees Celsius (10°C) and, starting from the highest temperature in the active heating zone 125, decrease outward through thermal conduction in the thermal heating zone 126, to the outermost annular line that represents fifty degrees Celsius (50°C). Put another way, an imaging having four nested annular lines (an example of which is shown in FIG. 23B) would mean that the first (innermost) ring represented eighty degrees Celsius (80°C), the second ring represented seventy degrees Celsius (70°C), the third ring represented sixty degrees Celsius (60°C), and the fourth (outermost) ring represented fifty degrees Celsius (50°C). Since the exemplary temperature needed for ablation of a tooth bud is sixty degrees Celsius (60°C), the shape of the ablation zone would be based on the next to last ring (in the four ring example, the third ring). The system could be adapted to using isotherms that represent different temperatures (e.g. eight degrees Celsius (8°C) or twelve degrees Celsius (12°C)). Further, the system could be adapted to alternative minimum temperatures needed for ablation for different soft tissues that require higher or lower temperatures for ablation.

[0145] FIGS. 16A-16C show photos that allow a comparison of the ablated tissue from a tissue ablation that was performed using known medical ablation systems (FIGS. 16A-16B) and the medical ablation system described herein (FIG. 16C). FIG. 16A shows the adverse impact of using conventional medical ablation at 2.45 GHz. The zone of ablation in the soft tissue is highly "ragged" in appearance in the active heating zone 125, was overheated at one end with tissue charring present, and is extremely oblong in shape as it asymmetrically migrated up the shaft of the ablation probe as the ablation probe heated up. FIG. 16B shows a zone of ablation produced at a higher frequency. It has a "tear-drop" shape that asymmetrically migrated outside the spherical shape of a tooth bud that occurred because the probe shaft became too hot and is also suboptimal for tooth bud ablation or other tissue types where the tear-drop shape is outside the targeted or prescribed zone of ablation. FIG. 16C shows a spherical zone of ablation generated using the tooth bud ablation probe described herein. The shaped zone of ablation represents a best fit inside the soft tissue of the tooth bud and can be configured to be oblate, spherical, or oblong along the path of ablation probe tip 100 insertion because the active heating zone 125 is predetermined with thermal energy conducting out of the active heating zone 125 and into the thermal heating zone 126 in a controlled fashion.

II.A. Ablation Probe:

[0146] FIGS. 8-13 show exemplary microwave ablation probe tips 100 (which, unless specified otherwise, generically include ablation probe tip 100a in FIG. 11, ablation probe tip 100b in FIG. 12, and ablation probe tip 100c in FIG. 13). These ablation probe tips are designed for thermal heating of tissues. The mechanism of thermal heating occurs in an active zone of heating (ablation zone) due to highly polar water molecule vibration for microwave (MW) or ion vibration in water for radiofrequency (RF). The shown and described structure of the ablation probe tips 100 conductively transfer excess heat in the target ablation zone out of the target ablation zone into non-targeted surrounding tissue at temperatures below the threshold where tissue destruction through thermocoagulation or thermal necrosis will occur.

[0147] The shown and described structure of the ablation probe tip 100 (including the near field antenna 110 - a coaxial cable with an annular aperture 120) uses "near field" energy emission into the ablation zone regions and, therefore, can be considered a near field antenna. (This can be thought of as a near field antenna having both the near field reactive and the near field radiative.) "Near field reactive" regions are approximately $\lambda/2\pi$ (~0.159) wavelengths or less in the antenna length of the ablation probe where the microwave energy is not propagating as a uniform wave. (A is the spatial period of a periodic wave - the distance over which the wave's shape repeats.) "Near field radiative" regions are approximately $\lambda/2\pi$ (~0.159) wavelengths up to ~0.25 wavelengths. As described below, near field radiation regions are distinctly different from far field radiation regions where the microwave signal spreads enough that waveforms propagate as more coherent waves in the far field radiation regions.

[0148] The shown and described structure of the ablation probe tip 100 preferably delivers energy that is non-resonant or noncoherent in a combined aperture/ablation zone dimension that is less than the frequency wavelength divided by 4 so as to minimize production of thermal energy along the shaft 102 of the ablation probe tip 100. The optional insulation annular layer 118 may be a thermally conductive outer sheath that further minimizes production of thermal energy along the ablation probe tip 100.

5 [0149] FIGS. 8-10 shows the shaft 102 of the ablation probe tip 100 having an insertion end 104 (that may be referred to as the "insertion tip," the "insertion point," and the "insertion tip point") at the end of the shaft 102. The insertion end 104 may be sharp enough to be self-introducing. The ablation probe tip 100 has a central coaxial antenna 110 (which can be thought of as a coaxial cable with an annular aperture 120). The central coaxial antenna 110 preferably includes an inner conductor 112, an annular dielectric insulator layer 114 (or other wave-guide), an annular outer conductor 116, and an optional insulation annular layer 118. Toward the end of the coaxial antenna 110 (near the insertion end 104) is an annular aperture 120 (which can be thought of as an annular window). An optional antenna end load 122 may be positioned between the aperture 120 and the insertion end 104 of the coaxial antenna 110 in order to increase the capacitive properties of the antenna to shorten the antenna center wire length, thereby making the focal region smaller (concentrating the total energy density) and increasing the power loading (power density) in the ablation zone. This will be discussed in more detail in relation to power loading control (section VI.). Surrounding the coaxial antenna 110 of shaft 102 (and spaced from the insertion end 104) is an annular heat transfer layer 130 (that may be referred to as a heat transfer layer 130, thermally conductive layer 130, or a thermal transfer shunt 130) and an annular tip cover 132 at the insertion end 104. The annular tip cover 132 covers and surrounds the end of coaxial antenna 110, the annular aperture 120, and the optional antenna end load 122. Further, the annular surface of the annular tip cover 132 farthest from the insertion end 104 preferably annularly abuts the annular surface of the thermally conductive layer 130 closest to the insertion end 104.

20 [0150] The central coaxial antenna 110 preferably includes an inner conductor 112 annularly surrounded by an annular dielectric insulator layer 114 (e.g. polytetrafluoroethylene (PTFE), air, or other known dielectrics) that is, in turn, surrounded by an annular outer conductor 116. The inner conductor 112 may be copper, copper- or silver-plated steel, or other conductive materials. The annular dielectric insulator layer 114 may be PTFE, air, or other known dielectrics that help form a wave guide between the center wire and the annular outer conductor. The annular outer conductor 116 may be a metallic shield such as a solid or woven copper or aluminum shield or other known metals.

25 [0151] The coaxial antenna 110 may be purchased, pre-made, or a combination thereof (e.g. purchased without an aperture and adding the aperture later or purchased without an insulation layer and adding the insulation layer later). The antenna may be an antenna design with a capacitive load on the end (as shown) or a dipole antenna with no capacitive load or an antenna having other method of loading the end of the antenna. Even though an antenna design with an end load is shown to increase capacitive coupling to shorten the length of the antenna, a dipole antenna with no end load or other form of capacitively loading the end of the antenna to lengthen or shorten the antenna can be considered.

30 [0152] The ablation probe tip 100 may also include an optional insulation annular layer 118 that provides thermal and electrical isolation between the outer annular surface of the outer conductor 116 and the inner annular surface of the heat transfer layer 130. Although shown with the optional insulation annular layer 118, alternative preferred ablation probe tips could omit the insulation annular layer. The optional insulation annular layer 118 may be part of a coaxial antenna 110 (e.g. a pre-made or purchased coaxial antenna). Alternatively, the optional insulation annular layer 118 may be added to a coaxial antenna 110 (e.g. a pre-made or purchased coaxial antenna) that does not have its own insulation layer. The insulation annular layer 118 may be made of materials including, but not limited to, plastic such as polymethylmethacrylate, polysulphone, or polyetherimide or other materials, such as zirconium dioxide or lithium disilicate ceramics capable of providing electrical isolation.

35 [0153] Toward the end of the coaxial antenna 110 (at least near the insertion end 104) is an annular aperture 120 that takes the form of a 360-degree groove. Put another way, the annular aperture 120 is a portion of the coaxial antenna 110 in which the annular dielectric insulator layer 114 is free from the annular outer conductor 116. Put yet another way, the annular aperture 120 is where the annular outer conductor 116 has been removed (or was never present) in an annular ring around the exposed annular ring of the dielectric insulator layer 114. As shown, there is a distance (space) between the annular edge of the heat transfer layer 130 and the insertion end 104 along the longitudinal length of the coaxial antenna 110 and the annular aperture 120 is shown as being located within the space. The center of ablation 124 (the focal point or region from which the ablation means radiates) is located within the inner conductor 112 at the annular aperture 120 (from which the ablation means emanates). As discussed in the center ablation control section (section III.), the ablation zones 150, 160, 170 stay centered around the annular aperture 120 and center of ablation 124 and do not migrate up the shaft 102. When the ablation probe tip 100 is assembled, the annular tip cover 132 covers the annular aperture 120.

40 [0154] As set forth herein, the optional antenna end load 122 is positioned between the annular aperture 120 and the insertion end 104 of the coaxial antenna 110 and acts to increase the capacitive properties of the antenna. The optional antenna end load 122 is preferably at least substantially perpendicular and adjacent to the end of the inner conductor 112. The optional antenna end load 122 functions as a capacitive concentrator such that the ablation means is altered or affected by the antenna end load 122 and radiates outward into the targeted tissue from a shorter effective antenna base.

45 [0155] The exemplary microwave ablation probe tip 100 has a shaft design with an annular heat transfer layer 130 (that may be referred to as a thermal transfer shunt or just shunt) at least partially surrounding the central coaxial antenna

110. The heat transfer layer 130 is preferably the outermost annular layer of at least the portion of the shaft 102 that it covers. As will be discussed in relation to FIGS. 11-13, the heat transfer layer 130 is positioned to create an oblate ablation zone 150, a spherical ablation zone 160, or an oblong ablation zone 170 along the shaft 102 of the ablation probe tip 100. The positioning of the heat transfer layer 130 may be predetermined or the heat transfer layer 130 may be positionable (e.g. movable, slidable, or otherwise associable at different positions) along the shaft 102, the shape of the ablation zones 150, 160, 170 being determined by the position of the heat transfer layer 130. In use, the heat transfer layer 130 partially extends into the ablation zone while part of the heat transfer layer 130 remains outside of the ablation zone. The heat transfer layer 130 is preferably made from material that both has high thermal conductivity and is electrically conductive (although electrical conductivity is not a requirement). Put another way, the heat transfer layer 130 is preferably a high thermal conducting layer. (On the other hand, the ablation probe tip 100 is both microwave transmissive and thermally nonconductive.) Exemplary material includes, but is not limited to, silver (Ag), copper (Cu), aluminum (Al), titanium (Ti), stainless steel (Ss), or any other material known or yet to be discovered that has high thermal conductivity and is electrically conductive. For example, silver has higher conductivity than copper, aluminum has high conductivity (but lower conductivity than copper), stainless steel has poor thermal conductivity, and titanium has poorer thermal conductivity than stainless steel. Additionally, non-metallic materials with thermal conduction properties that are 2 to 12 times greater than metals (such as diamond, boron nitride, pyrolytic graphite and graphene) can be used. (Graphene has a thermal transfer rate of up to 5,000.0 W/mC while silver is 406.0 W/mC.) The different thermal conduction properties of the different materials allow for the construction of devices having different measurable thermal conduction properties that can be used to create a variety of ablation probe tips for use in different applications. As discussed in ablation zone temperature control section (section IV.), preferred heat transfer layers 130 passively cool the ablation probe tip 100 by minimizing production of thermal energy along the portions of the ablation probe tip 100 substantially adjacent or near the heat transfer layer 130.

[0156] The exemplary microwave ablation probe tip 100 has a tip design with a tip cover 132 at the insertion end 104. The tip cover 132 is preferably made from material or substrate that has both high radio translucency (meaning that it is highly radiolucent or has low radiofrequency or microwave absorption rates) and low thermal conductivity (meaning that it is highly insulating or has low thermal conduction rates) while also being electrically nonconductive. Exemplary materials suitable for this purpose include, but are not limited to plastics such as polysulphone, polyetherimide and polymethylmethacrylate, but may also include ceramic substrates such as zirconium dioxide and lithium disilicate. Ablation probes with this tip design have the properties of allowing the microwave energy to escape preferentially (high radio translucency), blocking heat from returning into the ablation probe (low thermal conductivity) and high electrical isolation (low electrical conductivity).

II.B. Ablation Zones:

[0157] FIGS. 8-10 show the basic components of the ablation probe tip 100 and FIGS. 11-13 show the specific ablation probe tips 100a, 100b, 100c that create the three different shaped ablation zones 150, 160, 170.

[0158] While FIG. 9 shows three different ablation zones 150, 160, 170, it incorrectly shows a single aperture offset. FIGS. 11-13 correctly show the different aperture offsets 152, 162, 172 relative to the annular outer conductor 116 that would be necessary to create the respective ablation zones 150, 160, 170.

[0159] Similarly, FIG. 10 shows exemplary energy flow of the ablation probe tip 100a of FIG. 11, but the flows would be similar for the ablation probe tips 100b and 100c of FIGS. 12 and 13. FIG. 10 shows an exemplary energy flow of an exemplary ablation probe tip 100 that can be described in eight "flow steps" (FS1-FS8). Most of the flow step reference numbers point to arrows showing the direction of energy flow. Although described as "steps" to portray flow, in reality many of the steps occur continuously and/or simultaneously. This exemplary probe tip 100 is using microwave energy as its ablation means 62.

FS1: The ablation means 62 provided by the ablation source 60 is inserted or injected into the central coaxial antenna 110 and travels down the wave-guide (e.g. dielectric insulator layer 114) between the inner conductor 112 and annular outer conductor 116.

FS2: The ablation means 62 then exits out the annular aperture 120 near the antenna end load 122. The exiting of the ablation means entails energy acting in the near field reactive region of the antenna with an effective antenna length approximately $\lambda/2\pi$ (~0.159 wavelength) or less.

FS3: The ablation means 62 next begins to radiate outward as near field radiation out of the annular aperture 120 through an annular tip cover 132. The length of the annular aperture determines the effective antenna length and effective power loading (power density), with a

(continued)

larger annular aperture resulting in a lower effective power density going to the targeted tissue. As set forth herein, the annular tip cover 132 has the dual properties of being highly radiolucent to out-flowing MW or RF energy while also being highly insulating so that the ablation probe tip 100 does not conduct thermal energy back in as the ablation means 62 passes through it.

FS4: After traveling through the highly radiolucent annular tip cover 132, the ablation means 62 is subsequently absorbed into the living tissue 91 (that may be a tooth bud 92 or the surrounding tissue) around the annular tip cover 132 into what will become the active heating zone 125, which starts to rapidly heat up the tissue 91 as the MW or RF energy is converted to thermal energy.

FS5: As the tissue 91 around the annular tip cover 132 increases in temperature sufficient to form the ablation zone, the low thermal conductivity/high insulating properties of the annular tip cover 132 preferably blocks the tissue's thermal energy from conducting back into the ablation probe tip's 100 antenna structure and migrating up the central coaxial antenna 110 and annular outer conductor 116.

FS6: In addition to the dual properties of the annular tip cover 132, the shaft 102 of the ablation probe tip 100 also contains an electrically and thermally isolated annular heat transfer layer 130 that blocks transmission of the ablation means 62 up the shaft 102 while allowing thermal energy from the active ablation zone to conduct preferentially up the annular heat transfer layer 130 from the soft tissue 91 zone of ablation that is heating up.

FS7: The annular heat transfer layer 130 is "quenched" by transferring its thermal energy into the contacting soft tissue 91 that is not being directly heated by the ablation means 62 because the annular heat transfer layer 130 has blocked the ablation means 62 from migrating up the shaft 102.

FS8: The mechanism of cooling the annular heat transfer layer 130 by the adjacent soft tissue 91 not only occurs through its high thermal mass due to high water content, but soft tissues 91 are perfused by moving blood, which means heat is carried away from the annular heat transfer layer 130 and out of the surrounding soft tissue 91.

[0160] The shown aperture offsets 152, 162, 172 in FIGS. 11-13 create the different ablation zone shapes 150, 160, 170. More specifically, the length to width ratio (aspect ratio) of the ablation zone increases with an increase in aperture offset to take on a more oblong shape. Aperture offsets 152, 162, 172 can be described as the distances (set backs) between the annular aperture 120 (and/or the center of ablation 124) and the annular heat transfer layer 130. For consistency, the aperture offsets 152, 162, 172 shown and described herein are the distance between the center of the annular aperture 120 (shown as the effective center of ablation 124 and may also be referred to as the "center of the annular aperture 124") and the annular edge of the annular heat transfer layer 130 closest to the annular aperture 120. As the center of ablation 120 is stationary (does not migrate) as discussed in the center ablation control section (section III.), the center of ablation 124 and the center of the annular aperture 124 remain the same. It should be noted that, although the distances would be different, the aperture offsets could be measured from alternative points of reference (e.g. the annular edge of the annular outer conductor 116 closest to the annular aperture 120).

[0161] The examples of FIGS. 11-13 are based on exemplary ablation probe tips with apertures 1.0 mm to 1.5 mm. The exemplary frequency used was 12 GHz and the exemplary power used was 6.6 W. (Other frequencies, including 18 GHz, were able to produce shaped ablation zones.) The range of the aperture offsets are between 0.0 mm to 3.0 mm, but have been also measured to exceed 10.0 mm. Measurements were taken at twenty (20) seconds. Each probe was frequency-tuned in water to get the minimum reflected power reading prior to each ablation. (FIG. 17 shows the results of an exemplary probe experiment related to roundness of the zone ablation as it relates to both thermal conductivity of the annular outer conductor 116 and the effective aperture size 120.)

- FIG. 11 shows ablation zone 150 with an oblate shape. The aperture offset 152 is the shortest of the aperture offsets 152, 162, 172 and creates the oblate ablation zone 150. As an example, for a near field probe tip, the aperture offset might be less than 1.0 mm. The ablation zone 150 has a width/length aspect ratio of more than 1.0 (aspect ratio > 1.0). FIGS. 14A and 15A show ablation zone isotherms with an exemplary oblate shape.

- FIG. 12 shows an ablation zone 160 with a spherical shape. The aperture offset 162 has a length between the aperture offset 152 and the aperture offset 172 and creates the spherical ablation zone 160. As an example, for a near field probe tip, the aperture offset might be approximately 2.0 mm (or at least between 1.0 mm and 4.0 mm). The ablation zone 160 has a width/length aspect ratio of 1.0 (aspect ratio = 1.0). FIGS. 14B and 15B show ablation zone isotherms with an exemplary spherical shape.

- FIG. 13 shows an ablation zone 170 with an oblong shape. The aperture offset 172 is the longest of the aperture offsets 152, 162, 172 and creates the oblong ablation zone 170. As an example, for a near field probe tip, the aperture offset might be more than 4.0 mm. The ablation zone 170 has a width/length aspect ratio of less than 1.0

(aspect ratio < 1.0). FIGS. 14C and 15C show ablation zone isotherms with an exemplary oblong shape.

5 [0162] As will be discussed in the calibration section and in conjunction with the CT-guided ablation volume and/or diameter control (section V.), the ablation zone shaping may be calibrated. Further, there is no known competing technology that has this unique capability to shape the zone of ablation in a fixed oblate, spherical, or oblong shape with a fixed width/length aspect ratio throughout an ablation procedure and, therefore, no other medical ablation technology has this degree of ablation zone shaping capability.

10 III. Ablation Center Control

15 [0163] Conventional medical microwave ablation (MWA) and radiofrequency ablation (RFA) technologies were found to be suboptimal for tooth bud ablation for a number of reasons. Medical ablation systems were reviewed and rejected because they demonstrated substantial "migration" of the zone of ablation up the shafts of ablation probes during the procedure, thus resulting in an asymmetrical zone of ablation with respect to the center of ablation. The outer margin of the soft tissue ablation zone asymmetrically migrates up the probe tip shaft as the ablation probe heats. This means that the effective center of ablation migrates up the tip shaft as the ablation probe heats during the treatment cycle. This asymmetrical ablation zone migration makes predetermination or planning a medical ablation procedure extremely difficult for the operator and represents significant risk of damaging tissue outside the planned zone of ablation.

20 [0164] As set forth, the center of ablation 124 is positioned centrally within the inner conductor 112 and surrounded annularly by the annular aperture 120. The center of ablation 124 is also the effective center of the ablation zones 150, 160, 170. The center of ablation 124 is may also be referred to as the "center of the annular aperture 124." The ablation technology described herein has been designed to eliminate asymmetrical migration of the zone of ablation up the ablation probe tip shaft during the ablation procedure. Eliminating migration can be thought of as "fixing" the center of ablation 124 in place in relation to the center of ablation 124, the annular aperture 120, and/or the ablation probe tip 100. Put another way, preferred ablation probe tips 100 described herein have "stationary" (that may be referred to as "fixed") ablation zones 150, 160, 170 in that they stay centered on the annular aperture 120 and the center of ablation 124. This is shown in FIG. 19. The outer margins of the ablation zones 150, 160, 170 do not asymmetrically migrate up (toward the hand piece 52) the probe tip shaft 102 as the ablation probe tip 100 heats. Further, the effective center of ablation 124 within the center of the tissue does not migrate up (toward the hand piece 52) the probe tip shaft 102 as the ablation 100 heats up.

25 [0165] The ablation probe tip's annular outer heat transfer layer 130 in combination with the use of a near field antenna keeps the ablation zone's center stationary as the zone of ablation enlarges symmetrically outward, as shown in FIG. 19. As discussed in relation to FIG. 10 (FS6), the annular outer heat transfer layer 130 has dual properties: (1) it blocks transmission of the ablation means 62 from migrating up the shaft 102 and (2) it simultaneously allows thermal energy from the active ablation zone to conduct preferentially up the annular heat transfer layer 130 from the soft tissue 91 zone of ablation that is heating up.

30 [0166] Once the ablation probe tip 100 is positioned inside the targeted tissue 92, the ablation procedure is activated by the operator through use of the ablation source 60. The ablation means 62 flows through the ablation probe system 50 and radiates outward from the center of ablation 124. The energy/heat radiating outward from the center of ablation 124 forms the ablation zones 150, 160, 170. While energy is radiating outward from the center, the center of ablation 124 and the ablation zones 150, 160, 170 remains stationary in relation to the center of ablation 124 in that the ablation zones 150, 160, 170 stay centered about the center of ablation 124 and the outer margins of the ablation zones 150, 160, 170 do not migrate up the probe tip shaft 102 as the ablation probe tip 100 heats. Instead, properties of the near field antenna 110 (the central coaxial antenna 110) and/or the properties of the annular outer heat transfer layer 130 prevent the upward migration (away from the insertion end 104) in relation to the shaft 102. This is true regardless of whether the shape of the ablation zone is oblate, spherical, or oblong.

35 [0167] There is no known competing technology that has this unique capability to maintain the center of the zone of ablation in a fixed position throughout an ablation procedure and, therefore, no other medical ablation technology has this degree of centering capability.

40 IV. Ablation Zone Temperature Control

45 [0168] Another aspect of the tooth bud ablation process is ablation zone temperature control. The peak temperature is limited throughout the procedure in order to prevent tissue charring. Put another way, the temperature of the portion of the ablation probe tip that is inserted into tissue needs to be below a specified temperature to prevent it from killing tissue. For example, it is widely understood in the medical ablation industry that once the temperature of a surface rises above sixty degrees Celsius (60°C) for even a short period of time, the heat will kill any tissue that comes in contact with that surface. A comparison between over-heated tissue and properly heated tissue can be seen by comparing FIGS.

20A and 20B.

[0169] FIG. 20A shows over-heated tissue which can be seen as steam generated (shown as the wavy inner ring) in the center region in the active heating zone 125 around the ablation probe tip. This would occur when the peak temperature exceeded one hundred degrees Celsius (100°C). Steam generation dehydrates the tissue, which may lead to tissue charring and abnormal healing that includes residual scar formation. Put another way, failure to control the peak temperature may result in unpredictable healing that may lead to scarring. When scarring formation occurs, then it is possible that the soft tissue will not heal normally and may result in permanent tissue defects.

[0170] FIG. 20B shows properly heated tissue in which a thermal-capacitance-controlled ablation process does not exceed ninety degrees Celsius (90°C) to prevent charring. There is little potential for dehydration of the tissue during ablation or abnormal post-op healing with radiographically detectable scar formation when peak temperatures do not exceed one hundred degrees Celsius (100°C). Based upon multiple animal studies, when peak temperatures are limited to ninety degrees Celsius (90°C), the bone infills in a short period of time with no scarring and the tooth buds are no longer detectable on X-rays in just four (4) weeks. Keeping the peak temperatures to ninety degrees Celsius (90°C) or below, therefore, is highly desirable for tooth bud ablation, but it is desirable for other types of target tissue too where scarring is not a desired outcome.

[0171] There are two main types of temperature control that may be used in the ablation probe system: "passive" cooling and "active" cooling. Temperature is also affected by the power loading control as discussed in the power loading section (section VI.). Thermal capacitance that can be added to the heat transfer layers 130 can either be passive ("tissue quenching" or "thermal quenching") or through active thermal capacitance. Active thermal capacitance can be in the form of a cooling fluid (e.g. a liquid such as water or a gas such as air) being forced (circulated) through the ablation probe tip (e.g. through the heat transfer layer 130).

IV.A. Passive Cooling:

[0172] Preferred ablation probe tips 100 (including the probe tip shafts 102) described herein include passive cooling (passive ablation zone temperature control). For passive cooling, heat transfer layers 130 passively cool the ablation probe tips 100 by minimizing production of thermal energy along the portions of the ablation probe tips 100 substantially adjacent or near the heat transfer layers 130. The passive cooling of preferred ablation probe tips 100, therefore, keeps the probe tip shafts 102 relatively cool.

[0173] Ablation probe tips 100 described herein preferably use the thermal properties of the adjacent living tissue 91 (the specific thermal mass of the soft tissue 91 and the active blood perfusion of the soft tissue 91) to cool the ablation probe tip 100 and help shape the ablation zones 150, 160, 170. This feature can be referred to as "tissue quenching." Tissue quenching is shown in FIG. 10 (flow steps FS7 and FS8) which is discussed herein.

[0174] In the alternative to or in combination with using tissue quenching for passive cooling, "thermal quenching" may be used for passive cooling. Thermal quenching can be accomplished passively by adding additional thermal capacitance to the heat transfer layer 130. Exemplary ways of adding thermal capacitance are shown in FIGS. 26A-26D as the addition of at least one thermal capacitor (referred to and described generally as a thermal reservoir (TR) 134 that at least partially annularly surrounds the heat transfer layer 130 of an ablation probe tip such as one of the ablation probe tips 100 described herein). The thermal reservoir 134 is shown in FIG. 26A as thermal reservoir 134a, in FIG. 26B as thermal reservoir 134b, and in FIG. 26C as thermal reservoir 134c. FIG. 26D shows a cross-section taken along the longitudinal length of an ablation probe tip 100 that has a thermal reservoir 134. Although shown as a solid thermal reservoir 134a, with some modifications (e.g. for a fluid thermal reservoir 134b the cross section might distinguish the pipe 135a from the fluid therein), this could be a cross section of other types of ablation probe tips disclosed herein. Other changes to the cross-section would be needed based on other modifications/variations (e.g. if the optional insulation annular layer 118 was omitted) described herein. While the heat transfer layer 130 still functions as a heat pump (i.e. by drawing heat from the soft tissue zone by allowing thermal energy from the active ablation zone to be conducted preferentially up the annular heat transfer layer 130), the thermal reservoir 134 helps to cool the heat transfer layer 130 by transferring the heat from the heat transfer layer 130 into the thermal reservoir 134. Put another way, the thermal reservoir 134 absorbs heat from the heat transfer layer 130. Transferring heat into the thermal reservoir 134 quenches the heat transfer layer 130 which then maintains a high temperature gradient that facilitates continued high levels of heat transfer since no heat transfer can occur if there is no temperature gradient.

[0175] FIGS. 26A-26C show exemplary thermal reservoirs 134a-134c applied to exemplary ablation probe tips that have a heat transfer layer 130.

[0176] FIG. 26A shows a solid thermal reservoir 134a (e.g. an aluminum (Al) or a silver (Ag) thermal reservoir) implemented as a cylinder with an inner diameter (ID) of 2.1 mm annularly surrounding the heat transfer layer 130 such that the heat transfer layer 130 and the thermal reservoir 134a are thermally connected. (The cylinder may be constructed in many ways including, but not limited to, by drilling a blank of material, by applying a thick coating of material, by wrapping a sheet of material, by forming the heat transfer layer 130 and the thermal reservoir 134 as a single piece by

either additive 3D printing or subtractive machining, or by using any known or yet to be discovered method for effectively creating a cylinder.) Between the ID of the aluminum (or silver) cylindrical thermal reservoir 134a and the outer diameter (OD) of the heat transfer layer 130 may be a heat transfer grease (e.g. a high efficiency thermal grease such as GENNEL G107 with thermal conductivity or thermally conductive epoxy adhesive such as 3M TC-2810) to effectively couple the thermal reservoir 134 to the heat transfer layer 130. The shown thermal reservoir 134a is positioned over the heat transfer layer 130 at 20.0 mm from the center of ablation 124.

[0177] FIG. 26B shows a thermal reservoir 134b implemented as a copper (Cu) pipe or tube 135a with a 4.5 mm inner diameter (ID) filled with water and capped at both ends (end caps 135b) to keep the water contained within the pipe 135a. This can also be referred to as an H₂O thermal reservoir 134b. The water can be frozen (ice or solid water) to further increase its heat capacitance since there is no temperature change at zero degrees Celsius (0°C) as water goes from a frozen state to a liquid state and absorbs the latent heat of fusion energy to make this phase change. The shown thermal reservoir 134b is positioned over the heat transfer layer 130 at 20.0 mm from the center of ablation 124.

[0178] FIG. 26C shows a thermal reservoir 134c that forms at least part of the hand piece and surrounds at least part of the heat transfer layer 130 to form an ablation probe tip with an integrated hand piece and thermal reservoir assembly (referred to as an integrated assembly). The thermal reservoir 134c hand piece makes intimate contact with the heat transfer layer 130 and may provide sufficient thermal transfer capacity to cool the probe tip. A first preferred integrated assembly is a metal thermal reservoir hand piece that is constructed from metal. Metals that could be used include silver since it has a high thermal conductivity rate of 420.0 W/mC or aluminum with a moderate conductivity rate of 205.0 W/mC. A second preferred integrated assembly is a blended thermal reservoir hand piece that is constructed from a blend of thermal transfer compounds (e.g. boron nitride thermal fillers) and plastics (plastic/boron nitride blend) that is injection molded into the shape of the hand piece onto the heat transfer layer 130 so that the plastic/boron nitride blend hand piece acts as the thermal reservoir 134c. A third preferred integrated assembly is a superconductor thermal reservoir hand piece that is constructed from a superconductor (e.g. a nonmetal superconductor) that has a thermal conductivity rate that is greater than 420.0 W/mC (the thermal conductivity rate of silver). The shown thermal reservoir 134c is positioned over the heat transfer layer 130 at 20.0 mm from the center of ablation 124.

[0179] As will be discussed, there are several thermal-capacitance-control mechanisms (that may be referred to as means for controlling the thermal conductivity) that may be used to manipulate the thermal capacitance and the temperature gradient. For example, placing the thermal reservoir 134 toward the insertion end 104 of the ablation probe tip increases thermal transfer capacity (with an increased temperature gradient). Another example is that elongating the heat transfer layer 130 increases the capacitance, although the temperature gradient (with reduced thermal transfer rate) is lower than the temperature gradient created by placing the thermal reservoir 134 closer to the insertion end 104 of the ablation probe tip. Exemplary thermal-capacitance-control mechanisms can be used to adjust and/or optimize the thermal properties for a particular ablation probe tip and/or its intended use. The following is a partial list of such thermal-capacitance-control mechanisms:

- the temperature (e.g. initial temperature) of the thermal reservoir 134;
- the location of the thermal reservoir 134;
- the mass/dimension/volume (including the length and cross-sectional area) of the thermal reservoir 134;
- the material (which has a thermal capacitance) from which the thermal reservoir 134 is constructed (preferably taking into consideration the thermal conductivity rate);
- the mass/dimension/volume (including the length and cross-sectional area) of the heat transfer layer 130 (to determine the total heat transfer capacity);
- the material from which the heat transfer layer 130 is constructed (preferably taking into consideration the thermal conductivity rate);
- the power (e.g. source frequency) and/or energy applied to the ablation probe tip; and
- the duration (time) of the ablation cycle.

Using these thermal capacitance and heat transfer control mechanisms means that an ablation probe tip with a thermal reservoir 134 can have a predetermined maximum temperature (the hottest temperature to which tissue adjacent the ablation probe tip will be exposed) while delivering predetermined energy doses. Further, by controlling (including adjusting, determining, setting, and selecting control mechanisms such as the mass/dimension/volume and materials as well as using variable control mechanisms such as temperature, power, and duration) these thermal-capacitance-control mechanisms, the ablation probe tip can be optimized for particular purposes. These thermal-capacitance-control mechanisms can be used alone (adjusting only one thermal-capacitance-control mechanism) or together (adjusting multiple thermal-capacitance-control mechanisms). The following paragraphs will examine the effect of adjusting the thermal-capacitance-control mechanisms individually.

[0180] An optimal temperature and/or an optimal temperature range is the temperature or range of temperatures of the heat transfer layer 130 that is able to ablate the targeted tissue while mitigating damage to immediately adjacent

collateral (non-targeted) tissues. The optimal temperature of the heat transfer layer 130 that makes contact with tissue can be predetermined (set to a desired level or predetermined temperature) and then held at or below that level (temperature) using thermal-capacitance-control mechanisms such as those described herein. Alternatively, the optimal temperature range of the heat transfer layer 130 that makes contact with tissue can be predetermined (set within a desired level or predetermined temperature range) and then held within that level (temperature) range using thermal-capacitance-control mechanisms such as those described herein. The optimal temperature and/or the optimal temperature range is/are determined based on factors including the ablation probe tip design, the power source frequency and total energy dose, the sensitivity of the targeted tissue to heat, and other factors. For example, it is possible to predetermine an optimal temperature below sixty degrees Celsius (60°C) for the temperature of the surface of the heat transfer layer 130 that will make contact with tissue to prevent heat from killing tissue that comes into contact with that surface. FIG. 30A shows the tissue that was killed along the heat transfer layer 130. This can be compared to the photograph of FIG. 30B in which the tissue along the path of insertion was not killed because the ablation probe tip heat transfer layer 130 is kept at a temperature below forty-five degrees Celsius (45°C), which is low enough to prevent damage to the tissue even over extended ablation times.

[0181] If the optimal predetermined temperature of the heat transfer layer 130 is to be room temperature (twenty-three degrees Celsius (23°C)), some or all of the thermal-capacitance-control mechanisms can be adjusted (e.g. lowering the initial temperature of the thermal reservoir 134 and/or increasing the size (dimensions) of the of the thermal reservoir 134). The predetermined temperature of the heat transfer layer 130 could be lowered to five degrees Celsius (5°C) or lower. Looking at FIG. 28A, the ablation probe tip with a 20.0 mm heat transfer layer 130 and no thermal reservoir 134 exceeds one hundred degrees Celsius (100°C) at approximately twenty-five (25) seconds. (Using an ablation probe tip that exceeds one hundred degrees Celsius (100°C) would result in tissue damage as shown in FIG. 30A.) Simply elongating the thermal reservoir 134 to 125.0 mm dramatically drops the shaft temperature (it doesn't exceed seventy degrees Celsius (70°C) during the 40 second cycle), but it does exceed sixty degrees Celsius (60°C) by the end of the cycle because of the greater length and higher heat capacity and lower temperature gradient through which heat must be pumped. When additional thermal capacitance is added closer to the tip (in the form of thermal reservoir 134), the temperature does not exceed forty-five degrees Celsius (45°C) (which never kills tissue) throughout the entire cycle. (Using an ablation probe tip that does not exceed forty-five degrees Celsius (45°C) would result in no tissue damage for most tissue types along the insertion path as shown in FIG. 30B.)

[0182] The temperature (e.g. the initial temperature) of the thermal reservoir 134 affects the thermal capacitance. The temperature of the thermal reservoir 134 is a thermal-capacitance-control mechanism that may be controlled by setting or selecting the initial temperature (e.g. by cooling) of the thermal reservoir 134 and/or by adjusting the temperature if the thermal reservoir is temperature adjustable (e.g. using active cooling). Lowering the temperature of the thermal reservoir 134 increases the temperature differential (the difference in temperature between the thermal reservoir 134 and the heat transfer layer 130) such that the heat transfer layer 130 (cooling shunt) does not have to "pump" (or transfer) the heat as far or that more heat can be transferred in a shorter period of time. (There has to be a net temperature differential for heat to flow. If there is no temperature gradient or a zero-temperature differential, there is zero heat pumping and heat would not flow.) The greater the temperature differential, the more heat can be transferred and absorbed by the thermal reservoir 134. The temperature of the thermal reservoir 134 may be adjusted to increase the thermal capacitance of the thermal reservoir, for example, by dipping the thermal reservoir 134 into cold water, refrigerating the thermal reservoir 134, forcing (circulating) cooling fluids or cooling gases through the thermal reservoir 134, or any other means known or yet to be discovered for cooling the thermal reservoir 134.

[0183] The location of the thermal reservoir 134 affects the temperature differential which, in turn, affects the thermal transfer capacity of the heat transfer layer 130. The location of the thermal reservoir 134 is a thermal-capacitance-control mechanism that may be controlled by selecting the placement of the thermal reservoir 134 and/or by adjusting the placement if the thermal reservoir is a movable thermal reservoir that can slide up and down the shaft. More specifically, moving the thermal reservoir 134 toward the insertion end 104 increases the temperature differential. (Conversely, moving the thermal reservoir 134 away from the insertion end 104 decreases the temperature differential.) Increasing the temperature differential effectively means that the heat transfer layer 130 (cooling shunt) can pump more heat because it does not have to move the heat across a reduced temperature gradient. That means the closer the thermal reservoir 134 is moved towards the insertion end 104 the greater the temperature differential, resulting in greater thermal transfer rates. As previously stated, the greater the temperature differential, the more heat can be absorbed by the thermal reservoir 134.

[0184] Adjusting the mass/dimensions/volume of the thermal reservoir 134 affects the total thermal capacitance. The mass/dimensions/volume of the thermal reservoir 134 is a thermal-capacitance-control mechanism that may be controlled by setting or selecting the mass/dimensions/volume of the thermal reservoir 134 during manufacturing and/or when the user selects the ablation probe tip. For example, increasing the cross-sectional area, diameter, and/or length of the thermal reservoir 134 increases the amount of heat being pumped up the heat transfer layer 130 (cooling shunt) because a greater temperature differential can be maintained. The thermal reservoir 134 acts as a thermal capacitor that has

increasing thermal capacitance as the mass/dimensions/volume is increased.

[0185] The material from which the thermal reservoir 134 is constructed affects its thermal capacitance. The material of the thermal reservoir 134 is a thermal-capacitance-control mechanism that may be controlled by setting or selecting the material from which the thermal reservoir 134 is constructed during manufacturing and/or when the user selects the ablation probe tip. For example, using materials of higher thermal transfer capacity to construct the thermal reservoir 134 increases the amount of heat being pumped up the heat transfer layer 130 (cooling shunt) because a greater temperature differential can be maintained. A thermal reservoir 134 can be defined by the specific heat capacity of the thermal reservoir material in combination with the thermal conductive rate of the thermal reservoir material. A thermal reservoir 134 can include fluids (e.g. a liquid such as water or a gas such as air) or solids (e.g. ice or aluminum). For example, air (a gas) has almost no thermal capacitance and is a good insulator if it does not move. Another example is water (a liquid) that has a very high thermal capacitance. Aluminum has a low thermal capacitance compared to silver (i.e. it gets hot faster), but it conducts heat away faster than water (unless the water is forced (circulated) through the ablation probe tip). In addition to air, water, and aluminum, thermal reservoirs 134 may be made from or include conductive materials having good thermal transfer capacity including, but not limited to, silver, copper, diamond, superconductive materials (e.g. boron nitride, graphene, graphene nanotubes, and pyrolytic graphite), and combinations of materials such as water, aluminum, copper, and silver. Using non-metallic superconducting materials has advantages including, but not limited to: (a) the ablation probe tips may be smaller in diameter while conducting away the same amount of heat, (b) higher ablation powers may be used because they conduct more heat along the heat transfer layer 130 (cooling shunt) without damaging non-targeted tissues, and/or (c) lower temperatures can be used to protect the tissues that contact the ablation probe tip outside the targeted zone of ablation. The two or more materials mentioned above may be combined to create a combination thermal reservoir.

[0186] Adjusting the mass/dimension/volume of the heat transfer layer 130 affects the thermal transfer capacity of an ablation probe tip. The mass/dimensions/volume of the heat transfer layer 130 is a thermal-capacitance-control mechanism that may be controlled by setting or selecting the mass/dimensions/volume of the heat transfer layer 130 during manufacturing and/or when the user selects the ablation probe tip. For example, a shorter heat transfer layer 130 (e.g. a 20.0 mm heat transfer layer 130) has little or no effective thermal capacitance such that the ablation probe tip heats up quickly and stays hot. On the other hand, a longer heat transfer layer 130 (e.g. a 125.0 mm heat transfer layer 130) has more thermal capacitance and, therefore, keeps the heat transfer layer 130 cooler than the shorter heat transfer layer 130. Another example is that adjusting the cross-sectional area of the heat transfer layer 130 may affect the thermal transfer capacity of an ablation probe tip. A smaller cross-sectional area restricts the thermal transfer capacity of the heat transfer layer 130 such that the ablation probe tip heats up quickly and stays hot. On the other hand, an increased cross-sectional area of the heat transfer layer 130 (e.g. a 125.0 mm heat transfer layer 130) has more thermal transfer capacity and, therefore, pumps more heat along the heat transfer layer 130 due to the increased temperature gradient and keeps the ablation probe tip cooler than a smaller cross-sectional area heat transfer layer 130.

[0187] The material from which the heat transfer layer 130 is constructed affects its thermal capacitance. The material of the heat transfer layer 130 is a thermal-capacitance-control mechanism that may be controlled by setting or selecting the material from which the heat transfer layer 130 is constructed during manufacturing and/or when the user selects the ablation probe tip. This is similar to the description herein of the material of the thermal reservoir 134.

[0188] Adjusting the power and energy of the ablation energy affects how much heat is applied to the targeted tissue. The power applied to the ablation probe tip is a thermal-capacitance-control mechanism that may be controlled by selecting, setting, or adjusting the power (source frequency) applied to the ablation probe tip. The type of power/energy (ablation means) that is applied (e.g. microwave or radiofrequency) can be set during the manufacturing of the ablation probe tip and/or when the ablation probe tip is selected. The quantity of power/energy (the ablation means that may be measured in, for example watts (W) or joules (J)) supplied may be set and adjusted (increased or decreased) using the ablation source 60. The more power is applied, the hotter the heat transfer layer 130 becomes for a given ablation time cycle. When the other thermal-capacitance-control mechanisms are not optimized to prevent tissue damage, then the amount of energy and/or the power level may be limited to prevent unwanted tissue damage.

[0189] Adjusting the duration (time) of the ablation cycle affects how much heat is applied to the targeted tissue. The duration (time) is a thermal-capacitance-control mechanism that may be controlled by setting and/or adjusting the duration (time) during which the ablation means is applied to the ablation probe tip. Increasing the duration (time) increases the quantity of heat applied to the targeted tissue. Put another way, the longer the duration of the ablation, the hotter the heat transfer layer 130 becomes with a given amount of power. Decreasing the duration (time) decreases the quantity of heat applied to the targeted tissue. Put another way, the shorter the duration of the ablation, the less time the heat transfer layer 130 will have to become hot with a given amount of power. When the other thermal-capacitance-control mechanisms are not optimized to prevent tissue damage, then the amount of time may be limited to prevent unwanted tissue damage.

[0190] To prove the effectiveness of thermal quenching of the heat transfer layer 130, experiments were performed. In one such experiment, the ablation probe tips tested had the following properties: a 2.0 mm diameter x 125.0 mm

length silver heat transfer layer or cooling shunt (e.g. annular heat transfer layer 130), a 0.5 mm aperture offset, and an added 60.0 mm thermal reservoir 134, the end of which was positioned 20.0 mm from the end of the ablation probe tip (e.g. insertion end 104). The experiment included separate tests using three different thermal reservoirs: a water thermal reservoir 134 (constructed similarly to the fluid thermal reservoir 134b of FIG. 26B), an aluminum (Al) thermal reservoir 134 (constructed similarly to the solid thermal reservoir 134a of FIG. 26A), and a silver (Ag) thermal reservoir 134 (constructed similarly to the solid thermal reservoir 134a of FIG. 26A). Each of these thermal reservoirs were 60.0 mm long with a 6.4 mm diameter. For experimental purposes, all of the thermal reservoirs 134 were positioned over the heat transfer layer 130 in the same position relative to the insertion end 104, which was 20.0 mm from the center of ablation 124.

[0191] FIG. 27 shows equipment (camera equipment 140) used to obtain experimental results which may include, for example, an IR Camera (e.g. a FLIR® Model ETS320) that may be mounted on its side, a power source (in this case, a 12.0 GHz generator with output adjustable to up to 7.5 watts into the ablation probe tip), and modified ablation probe tips (e.g. ablation probe tips with the thermal reservoirs as described herein). The modified ablation probe tips used during the experiments were those shown in FIGS. 26A-26C and also described herein. Unmodified ablation probe tips were also used as controls.

[0192] During each test, the ablation probe tip 100 was inserted vertically down into a thirty-seven degrees Celsius (37°C) water saturated cosmetic sponge 138 to a depth of 10.0 mm (shown as probe insertion depth 136). The IR camera read the surface temperature of the heat transfer layer 130 at approximately 15.0 mm from the insertion end 104 of the ablation probe tip which is the middle of the exposed heat transfer layer 130 between the water-soaked sponge 138 and the start of the thermal reservoir 134. In practical use the probe insertion depth 136 may be at alternative points between the insertion end 104 and the thermal reservoir 134. Once the ablation probe tip 100 is properly inserted, the ablation cycle may be started. For experimental purposes, the microwave generator delivered forty (40) second microwave ablation cycles at 12.0 GHz with the power set at 5.5 watts into the ablation probe tip 100. The camera equipment 140 was used to record shaft temperatures 15.0 mm from the tip (i.e., midway between the water-soaked sponge 138 and the start of the thermal reservoir 134) and the temperatures of the thermal reservoir 134 during the ablation cycle. The tests were conducted at room temperature. The camera equipment 140 recording software (FLIR® Tools IR recording software) was triggered at the start of each 40 second ablation cycle and allowed to record for fifty (50) seconds.

[0193] The following table (which can be used in conjunction with the graphs of FIGS. 28A-28B and the chart of FIGS. 29A-29C) documents the sequence of some of the tests and the ablation probe tip with a thermal reservoir 134 configuration:

Run #s	Description of Ablation Probe Tip & Thermal Reservoir
1 & 6	<ul style="list-style-type: none"> • 23°C (Run #1) and 2°C (Run #6 - not performed because there is no thermal reservoir that can have a lower temperature) • 20.0 mm long silver heat transfer layer • No thermal reservoir
2 & 7	<ul style="list-style-type: none"> • 23°C (Run #2) and 2°C (Run #7 - not performed because there is no thermal reservoir that can have a lower temperature) • 125.0 mm long silver heat transfer layer • No thermal reservoir
3 & 8	<ul style="list-style-type: none"> • 23°C (Run #3) and 2°C (Run #8) • 125.0 mm long silver heat transfer layer • Thermal reservoir - 60.0 mm long with 6.34 mm OD copper tube with 4.5 mm ID filled with water
4 & 9	<ul style="list-style-type: none"> • 23°C (Run #4) and 2°C (Run #9) • 125.0 mm long silver heat transfer layer • Aluminum thermal reservoir - 60.0 mm long with 6.4 mm OD and 2.1 mm ID
5 & 10	<ul style="list-style-type: none"> • 23°C (Run #5) and 2°C (Run #10) • 125.0 mm long silver heat transfer layer • Silver thermal reservoir - 60.0 mm long with 6.4 mm OD and 2.1 mm ID

[0194] FIG. 28A shows the heat transfer layer "shunt effect" for Runs #1-#5 by showing the relationship of the temperature (shown with the degrees listed from thirty degrees Celsius (30°C) at the bottom of the vertical axis to one hundred ten degrees Celsius (110°C) at the top of the vertical axis) to the ablation energy duration (the time progression from the start of the recording and noted every five (5) seconds for forty (40) seconds). FIG. 28B shows the heat transfer layer "shunt effect" for Runs #8-#10 by showing the relationship of the temperature (shown with the degrees listed from

zero degrees Celsius (0°C) at the bottom of the vertical axis to forty degrees Celsius (40°C) at the top of the vertical axis) to the ablation energy duration (the time progression from the start of the recording and noted every five (5) seconds for forty (40) seconds).

[0195] In FIGS. 29A-29C (which is a single continuous chart), the various ablation probe tip constructions of Runs #1-#10 are listed over a series of time snapshots (every five (5) seconds) represented as rows in the chart. Temperature measurements are taken 10.0 mm from the insertion end 104 and, at the thermal reservoir 134 (listed as the "heatsink") if the configuration includes a thermal reservoir 134. The first half of the chart (which correlates to the information shown in FIG. 28A) shows results taken from tests in which the initial temperature of the thermal reservoir 134 is room temperature (twenty-three degrees Celsius (23°C)). The second half of the chart (which correlates to the information shown in FIG. 28B) shows results taken from tests in which the thermal reservoir 134 is chilled such that the initial temperature of the thermal reservoir 134 is a lowered temperature (approximately two degrees Celsius (2°C)).

[0196] The results shown in FIGS. 28A-28B and FIGS. 29A-29C clearly demonstrate that adding thermal capacitance starting at 20.0 mm from the ablation probe tip reduces the shaft temperature compared to unmodified ablation probes tips. Adding sufficient thermal capacitance keeps the ablation probe shaft at a relatively low temperature by creating a greater thermal gradient along the heat transfer layer 130.

[0197] The results shown in FIG. 28A-28B and FIGS. 29A-29C clearly demonstrate that increasing the length of the heat transfer layer 130 (listed as "shunt" in FIGS. 29A-29C) helps to lower the temperature of the shaft. More specifically, the added thermal capacitance created by increasing the length of the heat transfer layer 130 from 20.0 mm to 125.0 mm had a positive effect in reducing the temperature of the heat transfer layer 130 at the position 15.0 mm from the insertion end 104. By comparison, increasing the thermal capacitance by adding thermal reservoir 134 of Al, Ag, or Cu/H₂O 20.0 mm from the center of ablation 124 had an even greater effect in reducing the heat transfer layer 130 temperature at the position 15.0 mm from the insertion end 104. There was no practical difference between the effects on the capacitance when comparing thermal reservoirs 134 of Cu/H₂O, Al, or Ag. Significantly, there was no significant temperature change measured on the heat transfer layer 130 on the side exiting the thermal reservoir 134 because the thermal reservoir 134 is very effective at absorbing all the heat traveling through the heat transfer layer 130. The heat transfer layer 130 temperature can be optimized to limit the maximum temperature of the heat transfer layer 130 making contact with tissue along the probe shaft by increasing or decreasing the thermal capacitance depending on the application. As also shown, the shaft temperature can be further optimized by cooling the thermal reservoir to further limit maximum heat transfer layer 130 temperatures making contact with any tissue depending on the application.

IV.B. Active Cooling:

[0198] It should be noted that many known microwave ablation probe tips require active cooling of some sort (e.g. active movement of liquid coolant (such as water) or gas (such as CO₂) along the probe tip shaft or else the shaft superheats and charring of tissue along the shaft occurs with local temperatures sometimes exceeding three hundred degrees Celsius (300°C). Preferred ablation probe tips 100 described herein that create ablation zones less than 25.0 mm in diameter, however, they may not require active cooling to keep the probe tip shaft 102 from getting so hot that tissue 91 is ablated along the probe tip shaft 102.

[0199] Some preferred ablation probe tips 100 described herein may also include optional active cooling 54 (FIGS. 1A and 25) for ablation zones. In active ablation zone temperature control, feedback from the ablation source 60 (FIG. 1A) and/or from the ablation probe tip 100 (which may have at least one sensor 108 (FIGS. 2-3) along the shaft 102 to monitor, for example, temperature) may be provided to the user (or to electronic or digital monitoring systems that may be implemented by software) using an output mechanism 68 (FIG. 1A) such as a video display or audio display (speaker).

[0200] As shown in FIGS. 1A and 25, for the ablation probe systems 50 described herein, exemplary optional active cooling 54 (which includes cooling materials (represented as arrows) such as liquid coolant (such as water) or gas (such as CO₂)) may be provided via the hand piece 52 and/or directly to the ablation probe tip 100. Using the cross-section of an exemplary ablation probe tip shown in FIG. 25, the cooling material (represented as arrows) may flow (circulate) from the optional active cooling device 54 (that may be designed for cooling and/or circulating), through channels and/or openings 154 that are positioned in the heat transfer layer 130 toward the insertion end 104, and then return, through channels and/or openings 154 that are positioned in the annular outer conductor 116 to the optional active cooling device 54. If an optional insulation annular layer 118 is present, the cooling materials could flow (circulate) either inside or outside of the optional insulation annular layer 118 using channels and/or openings (not shown). Alternatively, the cooling 54 could travel (circulate) through channels and/or openings 154 incorporated in or through only the heat transfer layer 130. Using these or other types of active cooling methods, the heat transfer layer 130 that comes into contact with tissue can be regulated such that it does not exceed a maximum predetermined temperature.

[0201] There are at least many variables that can be controlled that relate at least tangentially to temperature control (active cooling): power/temperature, frequency/penetration, time/size, and shape/roundness.

- Power/Temperature: The power is kept low to prevent the maximum temperature from rising above ninety degrees Celsius (90°C).
- Frequency/Penetration: The frequency is selected to penetrate further into the tissue (i.e. there is less need for conduction and higher temperature).
- Time/Size: The size of the ablation zone may be determined by the duration of the ablation process (typically twenty to forty (20 to 40) seconds) for 5.0 to 10.0 mm diameter zones of ablation. In addition to controlling the total time of the duration of the ablation, modulating the energy on and off in a controlled fashion (pulse width modulation) is part of the time control.
- Thermal conductivity: The thermal transfer capacity of the heat transfer layer can be modified by increasing the thermal conductivity rate to increase the thermal transfer capacity of the heat transfer layer 130 or decreasing the thermal transfer conductivity rate to reduce the thermal transfer capacity of heat transfer layer depending upon the application.
- Thermal transfer cross-section area: The thermal transfer capacity of the heat transfer layer 130 can be modified by increasing the cross-sectional area to increase the thermal transfer capacity of the heat transfer layer 130 or decreasing the cross-sectional area to decrease the thermal transfer capacity of the heat transfer layer 130 depending on the application.
- Shape/Roundness: The shape/roundness of the ablation zones 150, 160, 170 is determined by the design of the ablation probe tip 100 including, for example, the size of the aperture offset (e.g. aperture offsets 152, 162, 172).

These variables, however, can be intertwined. For example, a large ablation zone (time/size) may take longer to heat (power/temperature) than a small ablation zone. Pulse width modulation of the time/energy may also improve the degree to which a zone of ablation becomes more oblate. The combination of the variables is generally controlled by the ablation source 60 that may be controlled manually (regular) and/or automatically (smart). At least an initial set of parameters for the variables may be part of a prescription (in a surgical kit) that is input (programmed) into the ablation source 60. The combination of the variables is based on an empirical map (developed based on extensive testing) and/or using at least one sensor that provides feedback.

[0202] An empirical mapping of the ablation process shows the maximum temperature and temperature gradients are based on total energy/power and frequency. Empirical testing may be used, for example, to determine the maximum energy input (power) as a function of time. After conducting extensive testing and mapping out the maximum temperatures, over heating may be avoided by controlling the variables (e.g. controlling power input or increasing the thermal transfer capacity of the heat transfer layer 130).

[0203] Alternatively, or in conjunction with empirical testing, at least one external temperature sensor may be placed on or in the surface of the ablation probe 100. Having precise energy (power) delivery control with feedback from at least one sensor can be a key component to temperature control. There are a number of fiber optic-based temperature sensors that do not interfere with the microwave energy emission including, for example, fiber optic temperature sensor solutions from OSENSA Innovations (Burnaby, BC, Canada). The temperature feedback from at least one fiber optic sensor can be provided to (coupled into) the ablation source 60 to adjust and maintain a targeted temperature.

[0204] Feedback may be provided as input to the ablation source 60. Feedback may be provided to the user using an output mechanism 68 such as a video display or audio display (speaker). The user could then manually adjust the parameter settings 64 and the treatment time settings 66 (including stopping the treatment) of the ablation source 60. Feedback may also (or in the alternative) be provided directly to an output mechanism 68 (e.g. a smart generator) (or to electronic or digital monitoring systems associated therewith that may be implemented by software associated with the ablation source 60) that automatically adjusts the parameter settings 64 and the treatment time settings 66.

V. Guided Ablation Volume and/or Diameter Control

[0205] Ablation volume control is another aspect that can be instrumental in procedural success. To this end, the ablation source 60 (e.g. a "smart" ablation generator) precisely delivers prescribed ablation zone volumes. The ablation zone volumes are determined pre-operatively through volume scan imaging and provided as a prescription along with parameters of the relative variables (e.g. time and power). The ablation source 60 preferably controls the energy delivery (e.g. rate and time) to generate the prescribed ablation zone volume inside the bony crypt of the tooth bud. This allows the system to deliver ablation zone margins +/- 0.5 mm (within statistical limitations) for the prescribed ablation. This technology has the unique capability of being able to predetermine and deliver the final diameter and ablation volume with this degree of precision.

[0206] FIG. 21 shows four images: an original image (top left) and three images (top right, bottom left, and bottom right) with marking thereon. The top left image is of the targeted tooth bud. The three marked drawings each include a dashed line circle that represents the tooth bud. The three marked drawings also include a solid-line circle with arrows radiating from the center to the interior perimeter of the solid-line circle that represents the ablation zone. The top right

image shows the tooth bud under-ablated because the ablation zone is significantly smaller than the tooth bud. The bottom left image shows the tooth bud over-ablated because the ablation zone is larger than the tooth bud. The bottom right image shows the tooth bud correctly ablated because the ablation zone is a relatively tight fit (the annular distance between the ablation zone within the tooth bud may be a bit exaggerated) to the tooth bud.

5 **[0207]** Using the prescription from the volume scan guided procedure, the ablation means 62 (e.g. the "smart" microwave generator) controls energy delivery (both rate and time) to generate the prescribed ablation zone volume inside the bony crypt of the tooth bud once the ablation probe tip is in the correct position.

10 **[0208]** Extensive experiments were performed both on tooth buds (ex vivo) and on pork loin to determine the estimated duration required for variation ablation diameters. The results of the experiments were analyzed and the graph in FIG. 22 and the table below show some of the results. In the FIG. 22 graph, the solid line shows the diameter estimates for ablations in tooth buds for various durations. The dashed line above the solid line shows diameter estimates for ablations in pork loin. The chart below adds the additional variable of the specific diameter that would represent the bony crypt diameter along with a correlation of ablation duration to the estimated diameter of the ablation zone.

15

Ablation Duration Table For In Vivo Pig Ablations		
Largest Bony Crypt Diameter Measured in CT Image (mm)	Ablation Duration (seconds)	Estimated Ablation Zone Final Diameter (mm)
4.0 to 4.5	20	6.2
4.6 to 5.0	25	6.8
5.1 to 5.5	30	7.2
5.6 to 6.0	40	8.0
6.1 to 6.5	45	8.4
6.6 to 7.0	55	9.0
7.1 to 7.5	65	9.6
7.6 to 8.0	75	10.1
8.1 to 8.5	85	10.6
8.6 to 9.0	95	11.1
9.1 to 9.5	110	11.7

30

35 VI. Power Loading Control

[0209] As set forth herein, the length of the annular aperture (and the size of the focal region therein) determines the effective antenna length and/or effective power loading (that may be referred to as "power density" and "power loading density"). Compared to larger annular apertures, smaller annular apertures produce relatively higher effective power densities in the targeted tissue's active heating zone 125. Compared to smaller annular apertures, larger annular apertures produce relatively lower effective power densities going to the targeted tissue's active heating zone 125. Because the size of the annular apertures can be controlled and/or predetermined, the power loading densities can be controlled and/or predetermined (a predetermined power loading density).

45 **[0210]** As set forth herein, the length of the annular aperture (and the size of the focal region therein) determines the effective peak temperatures in the active heating zone 125. Compared to larger annular apertures, smaller annular apertures produce relatively higher effective peak temperatures in the active heating zone 125 when the same power is being delivered. Compared to smaller annular apertures, larger annular apertures produce relatively lower effective peak temperatures in the active heating zone 125 when the same power is being delivered. Because the size of the annular apertures can be controlled and/or predetermined, the peak temperatures in the active heating zone 125 can be controlled and/or predetermined to be high peak temperatures, medium peak temperatures, low peak temperatures (a predetermined peak temperature). The peak temperatures are relative to other ablation probe tips and systems having the same parameters and/or variables.

50 **[0211]** As set forth in the ablation probe tip section (section II.A.) of the ablation zone shaping control section (section II.), an antenna end load 122 near the aperture 120 of the coaxial antenna 110 increases the capacitive properties of the antenna 110 to shorten the antenna center wire length. This makes the focal region 124 smaller (concentrating the energy density) and increases the power loading (power density) in the ablation zone 150, 160, 170 (shown in FIGS.

23A-23C as ablation zones 160a, 160b, 160c, which are variations of the spherical ablation zone 160). There are other ways to change (increase/decrease) the size of the focal region 124 including, but not limited to, antenna designs that use pigtail and other known techniques and technology used to add end loads to increase antennas' power loading.

5 [0212] FIGS. 23A-23C and FIGS. 24A-24C are graphic and photographic images that show the effect that the size of the focal region (the center of ablation 124 bounded by the annular aperture 120 (shown as 120a, 120b, 120c in FIGS. 23A-23C) has on the creation of ablation zones 150, 160, 170 (although only the approximately spherical ablation zone 160 is shown). Other than the size of the annular aperture 120, the variables (e.g. time, power, and so forth) in the experiments documented by these photographs remained constant. The rings on these photographs are like the rings in FIGS. 15A-15C in that the isotherms (annular lines) surrounding the focal region each represent ten degrees Celsius (10°C) and the outermost isotherm (annular line) represents fifty degrees Celsius (50°C). Exemplary isotherms are labeled in FIGS. 23A-23C.

10 [0213] The rate of heating (delta temperature / delta time) increasing as the annular aperture gets smaller can be shown mathematically. Power density can be thought of as the amount of power (time rate of energy transfer) per unit volume. In this equation (and an example only), the amount of power is expressed in watts (W) and the unit volume is expressed in cubic millimeters (mm³). If 5.0 W of microwave energy were applied to an ablation probe tip with an annular aperture that is 1.0 mm long, the power density would be approximately 5.0 W/mm³. If 5.0 W of microwave energy were applied to an ablation probe tip with an annular aperture that is 4.0 mm long, the power density would be approximately 1.25 W/mm³.

15 [0214] The ablation probe tip shown in FIG. 24A has a small focal region that creates high power loading density in the ablation zone 160a. More specifically, the focal region is a 0.8 mm (length along the probe shaft) annular aperture 120a. If 5.0 W of microwave energy were applied to this ablation probe tip, the power density would be approximately 6.25 W/mm³ as the microwave energy first begins to enter the tissue. The inner peak ablation zone temperature in the active heating zone 125 is ninety degrees Celsius (90°C). FIG. 23A shows a similar ablation probe tip 100 that creates a spherical ablation zone 160a (although other shapes could be created using ablation probe tips with shorter or longer aperture offsets) with an active heating zone 125 and a thermal heating zone 126. The short annular aperture 120a bounds a short/small focal region 124 that, in turn, results in a short/small zone of active heating that creates high power loading (represented by the relative closeness (tight spread) between isotherms in the thermal heating zone 126 of the ablation zone 160a).

20 [0215] The ablation probe tip shown in FIG. 24B has a medium focal region that creates medium power loading density in the ablation zone 160b. More specifically, the focal region is a 1.5 mm (length along the probe shaft) annular aperture 120b. If 2.4 W of microwave energy is applied to this ablation probe tip, the power density would be approximately 3.3 W/mm³ as the microwave energy first begins to enter the tissue. The inner peak ablation zone temperature in the active heating zone 125 is eighty degrees Celsius (80°C). FIG. 23B shows a similar ablation probe tip 100 that creates a spherical ablation zone 160b (although other shapes could be created using ablation probe tip with shorter or longer aperture offsets) with an active heating zone 125 and a thermal heating zone 126. The medium annular aperture 120b bounds a medium focal region 124 that, in turn, results in a medium length/size zone of active heating that creates medium power loading (represented by the intermediate spread isotherms in the thermal heating zone 126 of the ablation zone 160b).

25 [0216] The ablation probe tip shown in FIG. 24C has a large focal region that creates low power loading density in the ablation zone 160c. More specifically, the focal region is a 4.0 mm (length along the probe shaft) annular aperture 120c. If 2.4 W of microwave energy is applied to this ablation probe tip, the power density would be approximately 1.25 W/mm³ as the microwave energy first begins to enter the tissue. The inner peak ablation zone temperature in the active heating zone 125 is seventy degrees Celsius (70°C). FIG. 23C shows a similar ablation probe tip 100 that creates a spherical ablation zone 160c (although other shapes could be created using ablation probe tips with longer or longer aperture offsets) with an active heating zone 125 and a thermal heating zone 126. The long annular aperture 120c bounds a long/large focal region 124 that, in turn, results in a long/large zone of active heating that creates low power loading (represented by the relatively large distance (wide spread) between isotherms in the thermal heating zone 126 of the ablation zone 160c).

30 [0217] Power density is one of the capabilities of an ablation probe tip 100 that would be relevant for calculations performed, for example, by software. Selecting an ablation probe tip 100 with an annular aperture 120 of a known or predetermined length will produce an ablation zone 150, 160, 170 with a known or predetermined power loading. The ablation probe tip 100 with the predetermined-sized annular aperture 120 may be included in a surgical kit or the prescription may specify ablation probe tip 100 with the predetermined-sized annular aperture 120 to be used in the procedure.

35 [0218] As a point of clarity, it should be noted that the power density is at least substantially independent from the shape of the ablation zone 150, 160, 170. Whereas the power density is related to the size of the annular aperture 120, the shape of the ablation zone 150, 160, 170 is related to the aperture offsets 152, 162, 172.

Calibration:

[0219] The ablation probe systems 50 are preferably calibrated. This may be accomplished by performing a plurality of ablations (e.g. 150 ablations in tooth bud tissue from freshly harvested mandibles and maxillas of sacrificed animals) and using the results to establish a "calibration curve" based upon the resulting ablation of the tissue.

[0220] A volume scan is taken of the targeted tissue. This image may be used to determine, for example, the volume/diameter of the zone of ablation, the shape of the zone of ablation, and/or the position of the zone of ablation.

[0221] After the diameter of the bony crypt of each tooth bud is measured, a "best fit" ablation zone may be created, for example, by selecting an ablation probe tip 100 and the system settings based upon an ablation probe system's actual ablation volume properties. Put another way, a probe with known predetermined three-dimensional ablation profile is used. The size and shape of the ablation probe tip 100 is also relevant, as it would relate to the positioning provided by the custom surgical stent 80. Finding the "best fit" would preferably include determining that the volume/diameter of the zone of ablation is adjusted to fit the individual tooth buds. Further, finding the "best fit" would preferably include determining that the shape of the zone of ablation is adjusted to fit the individual tooth buds. Put another way, the ablation zone shape is preferably controlled to fit inside the tooth bud. (For example, if the tooth bud is oblong, then an oblong ablation zone is produced.) The adjustment of the size and shape may be accomplished by, for example, selecting the ablation probe tip 100 with the appropriate annular aperture 120 to create the appropriate ablation zones 150, 160, 170. Another method to alter or control shape is by using pulse width modulation of the energy going out the probe. Properly positioning the ablation probe tip 100 using the procedures described in the Therapeutic Tooth Bud Ablation Properties and herein, the ablation zones are clearly circumferentially centered around the tooth bud and greatly reduce the incidence of any adjacent non-targeted tissue (e.g. nerves, teeth, etc.) being damaged.

[0222] The area of the ablation zones may be calculated using the following exemplary equation or other known area calculation methods (that may be more detailed and/or provide more accurate results):

$$\text{Area} = \text{average length} * \text{average width} * \pi$$

The roundness of the ablation zones may be calculated using the following exemplary equation or other known roundness calculation methods (that may be more detailed and/or provide more accurate results):

$$\text{Roundness} = \text{average width} / \text{average length}$$

Other methods for determining the area and roundness of the ablation zone may be used including, but not limited to, direct observation, measurement, and other known or yet to be discovered empirical means for determining the area and roundness of the ablation zone.

Exemplary Use:

[0223] There are many advantages to prophylactically preventing the formation of third molars using methods, systems, and procedures described both herein and in the Therapeutic Tooth Bud Ablation Properties. Earlier intervention is safer due to anatomy (the tooth bud is separated by 5.0-10.0 mm from the mandibular canal), tooth development (the crown of the adjacent first and/or second molars 95 is generally well developed), and improved healing (smaller surgical footprints reduce post-operation healing issues).

[0224] Using the apparatuses, methods/procedures, and systems described herein for inducing tooth agenesis, the clinical goal is predictable efficacy for inducing tooth agenesis with zero long-term adverse side effects. The apparatuses, methods/procedures, and systems described herein may be used in the apparatuses (customized surgical stents 80, virtual stents 82', 86', 88', and/or surgical kits), methods/procedures, and systems described in the Therapeutic Tooth Bud Ablation Properties. For example, the probes may be used with customized surgical stents 80 or virtual stents 82', 86', 88' for proper placement. A surgical kit (including an ablation probe system 50, custom surgical stent 80, and ablation energy dose tolerances) is configured with the goal of statistically maintaining +/- 0.5 mm total ablation zone positioning control inside each tooth bud.

[0225] The following exemplary steps may be used for tooth agenesis (although the order may vary - e.g. the hand piece 52 may be connected to the ablation source 60 after the patient is seated):

- Routine Screening Ages 6-14: Routine screening to determine the presence of tooth bud 92 (e.g. third molar tooth buds) formation in two-year increments between age 6 and age 14 because of the wide range of ages that reflects the degree of variability in the formation of tooth buds. The screening may be accomplished using scanning

techniques such as low-dose digital panoramic imaging techniques (which are common to at least most pediatric and most general dentists) or even new technologies such as ultrasound.

▪ **Diagnosis and Volume Scan Imaging:** Once the presence of tooth buds has been diagnosed during screening, a pre-operative imaging step is performed to determine the three-dimensional location and volume of each tooth bud 92. This imaging can be practically accomplished using, for example, dental CBCT three-dimensional volume scans using a voxel resolution of 0.4 mm or better. The result is a three-dimensional digital volume scan.

▪ **Pre-Operation Impressions:** A dental impression (conventional physical or digital dental impression) is obtained of the teeth and soft tissue (gums) in at least the quadrant of interest. This impression captures the surface of the gum tissue and detail of the teeth. Erupted first and/or second molars 95 and/or the primary dentition are used to physically stabilize surgical stent(s) 80. The creation of digital impressions is described in more detail in the Therapeutic Tooth Bud Ablation Properties.

▪ **Doctor's Prescription for Services:** In one preferred method, a dental professional may complete and electronically sign an online prescription form. The electronically signed prescription is preferably completed with the uploading of the three-dimensional digital image (e.g. digital CBCT image) and at least one dental impression.

▪ **Ablation Probe Tip 100:** The ablation probe tip 100 will have a defined or known ablation zone 150, 160, 170. The ablation probe tip 100 will have a defined or known depth of penetration. The ablation probe tip 100 will preferably be self-introducing through the gingival tissue 94 into the tooth bud 92. In practice, a family of ablation probe tips 100 may be produced and shipped in a surgical kit.

▪ **Creation of Custom Surgical Stent 80:** The custom surgical stent 80 may be fabricated using the surgical stent design software suite that may be implemented as one or more programs, subprograms, applications, or modules.

▪ The three-dimensional digital image and at least one dental impression are imported into the surgical stent design software suite. The specific ablation probe tip 100 or possible ablation probe tips 100, and the specifications therefore, are preferably known by (or provided to) the surgical stent design software suite so that the surgical stent design software suite can take the profile, dimensions, and/or capabilities (e.g. power density) of the ablation probe tip(s) 100 into consideration when designing the surgical stent 80. The surgical stent design software suite designs the surgical stent 80 with at least one surgical guide 82 and at least one mechanical stop 86 to guide and limit the placement of the ablation probe tip 100 into the tooth bud 92. (Put another way, the surgical stent design software suite calculates and provides ideal probe positioning and entry angle data and depth data that is required for optimal placement of the ablation probe's center of ablation 124 into the targeted tooth bud 92 with a total system tolerance of +/- 0.5 mm for total ablation zone positioning control. This information may then be used to calculate the data necessary to create the at least one surgical guide 82 and at least one mechanical stop 86.) The surgical stent design software suite also designs the surgical stent 80 to mate with the patient's soft tissue (gums), preferably including the soft tissue covering the tooth bud 92. The surgical stent design software suite also designs the surgical stent 80 to mate with the patient's erupted teeth (e.g. primary and/or permanent first and/or second molars 95) such that the erupted teeth act as physical rests to hold the surgical stent 80 in place.

▪ The surgical stent design software suite designs and fabricates custom surgical stents 80 in accordance with the methods discussed in the Therapeutic Tooth Bud Ablation Properties and known methods. Further, the surgical stent design software suite preferably formats the information about the custom designed surgical stent to be held as at least one output file (e.g. an *.stl output file). The output file(s) may be used for creating the surgical stent 80 using, for example, three-dimensional printing. In other instances, the output files may result in mapping a virtual stent 82', 86', 88'.

▪ The surgical stent design software suite may work with CBCT software or may include custom software enhancements in CBCT software that assists in the rapid design and manufacturing of the custom surgical stents 80.

▪ **Determination of Optimal Settings:** The surgical stent design software suite preferably calculates and/or defines the optimum intra-operative ablation power and time settings (power and time dosage). (FIG. 18 shows the effects of power and time on the ablation area in an exemplary modeling.) The determination of ideal power and time (duration) settings for ablation take into consideration factors including, but not limited to, the profile of the ablation probe systems 50 (e.g. the zone(s) 150, 160, 170 produced by the ablation probe tip(s) 100), the tooth bud dimensions (computed from the volume scan images in the surgical stent design software suite), and the patient's age (during the ages of 6-12, a patient's tooth buds will generally have a diameter in the range of 4.0 mm to 12.0 mm). Ablation dose energy and treatment times are preferably incrementally compensated for increased tooth bud volumes. These patient and tooth-specific settings are then stored in a database (e.g. a volume scan information technology file) for later upload to the ablation source 60 when the operator sets it up or it may be part of the custom surgical guide kit (e.g. a prescription).

EP 4 231 953 B1

▪ Custom Surgical Kits: Components of the custom surgical stent may be fabricated using a surgical stent design software suite that may be implemented as one or more programs, subprograms, applications, or modules to control production and/or calculate digital data (e.g. parameter settings 64 and/or treatment time settings 66).

5 ▪ A custom surgical kit preferably includes necessary components for the procedure. These necessary components include, but are not limited to, at least one sterile custom surgical stent 80, at least one sterile probe tip (ablation probe tip 100), instructional paperwork (or an indication of where instructions may be found - e.g. online), the calculated optimal settings (or an indication of where the optimal settings may be found - e.g. online), and/or a patient identification key provided with the kit. The custom surgical kit is preferably disposable.

10 ▪ It should be noted that some of the custom surgical kit components may be combined. For example, the instructional paperwork may be a small card with a website address and the patient identification key. The user may enter the patient identification key at the website address to obtain the calculated optimal settings.

 ▪ It should be noted that the "instructional paperwork" may be printed or may be accessed electronically (e.g. via a website, a CD, or a thumb drive).

15 ▪ The at least one ablation probe tip 100 in the surgical kit is matched to the patient's custom surgical stent 80. Alternatively, a family of probe tips (e.g. 2-10 ablation probe tips) may be included in the surgical kit to cover multiple possible tooth bud depth and tooth bud volume relationships. The family of probe tips would have probe tips of differing characteristics such as differing lengths (e.g. the distance from the tip mechanical stop 106 to the center of ablation 124 and/or the distance from the tip mechanical stop 106 to the insertion end 104), connection structure (e.g. the connections structure that mates with the hand piece 52) and/or widths. If a family of probe tips is provided, the correct ablation probe tip 100 would be clearly indicated or a method for determining the correct ablation probe tip 100 would be provided (e.g. color-coding on the manufactured stent with a table showing which ablation probe tip would be used for each color). Alternatively, the surgical kit may not include a probe tip, but instead include a specific indication as to the ablation probe tip 100 that is necessary (e.g. ablation probe tip 100 that is matched to the patient's custom surgical stent 80). This specific indication might include the brand, model, and size of the correct ablation probe tip 100. The ablation probe tip(s) 100 may be individually packaged (or packaged as a family), sterile, and disposable.

20 ▪ The custom surgical kit is preferably labeled and packaged. Labeling may be customized for each package to indicate information including, but not limited to, the patient's name (and/or other identifying information), part numbers, treating doctor's name (and/or other identifying information such as the address), and the patient identification key.

25 ▪ Operator Use of the Custom Surgical Kit to ablate a tooth bud 92 (without ablating overlying gingival tissue 94) with minimal pain and minimal infection potential.

30 ▪ The operator sets up for the procedure by powering up the ablation generator (ablation source 60). On power up the correct procedure information or patient identification key (that may be any predetermined information or code) is preferably entered into the generator, which then accesses and downloads the patient's name and preprogrammed settings for each tooth to be ablated from a database (that may be a database controlled by a central company or one of many databases). The system may be structured such that the preprogrammed settings cannot be changed (i.e. an operator cannot input or adjust the power level or time settings).

35 ▪ The hand piece 52 is preferably functionally connected to the ablation source 60. The disposable ablation probe tip 100 is preferably also functionally attached to the ablation hand piece 52. The hand piece 52 may have a "chuck" (that may be a push-button electrical connector "chuck" that provides rapid and reliable setup and easy maintenance) into which the ablation probe tip 100 may be inserted and secured.

40 ▪ The operator may start the procedure by placing the surgical stent 80 onto the patient's teeth prior to administering local anesthetic. Then the local anesthetic (1/4 carpule per site) is generally administered through the surgical guides 82 of the surgical stent 80, and directly into or around the tooth bud 92 by placing the tip of the needle into the predetermined physical location. Precision placement of the anesthetic reduces the quantity necessary for the procedure.

45 ▪ Once the patient is anesthetized, a waiting period is preferably provided to allow the anesthetic solution to physically dissipate to avoid altering the tooth bud's volume. During the waiting period, the operator may functionally connect the sterile ablation probe tip 100 to the hand piece 52 and power-on the ablation source 60 if these steps have not already been performed. The surgical stent 80 may also be resealed at this time.

50 ▪ When everything is ready, the operator begins performing the ablation procedure by reseating the surgical stent 80 (if it hasn't already been done), gripping the hand piece 52, and inserting the self-penetrating ablation probe tip 100 through the surgical guide 82 to a full stop to puncture and penetrate the oral mucosal tissue and come to a correct final stop position with the center of ablation 124 within in the tooth bud 92 (e.g. in the middle

of the tooth bud 93). To verify full-stop positioning, the ablation probe tip 100 is pressed to a full stop to secure the probe tip shaft in the surgical stent 80 (and particularly to the area surrounding the surgical guide 82) to position the ablation probe tip 100 at the predetermined angle and depth of the probe tip's predetermined center of ablation 124 in the center of the tooth bud 92.

5 ▪ Once the ablation probe tip 100 is positioned so that the center of ablation 124 is in the center of the tooth bud 92, the ablation source 60 may be activated. Activation may be accomplished using a direct activator (button) or a remote activator (e.g. a wireless foot pedal) in order to deliver the total energy dose according to the patient-specific time/power levels.

10 ▪ Ablation times are set based upon the system power, predetermined tooth bud volume and other parameters. The ablation means 62 will preferably monitor the procedure progress. The ablation probe tip 100 output may be monitored by percentage of reflected energy in order to positively confirm delivery of the proper procedure ablation dose. A visual and/or audible signal may be provided to indicate a successful delivery of the ablation energy when the ablation is complete.

15 ▪ The operator then withdraws the ablation probe tip 100 and removes the surgical stent 80. No sutures are required and there is generally very little bleeding following the procedure. The patient is free to assume normal activities immediately.

Distinctions:

20 **[0226]** The NEUWAVE™ Microwave Ablation System is described in the Background. It is described as being able to ablate lesions with consistency and control to help protect non-targeted tissue. More specifically, the NEUWAVE™ System and NEUWAVE PR Probe is described as having a burn pattern that controls the ablation distance past the probe tip. The NEUWAVE™ System always produces an oblong ablation zone that asymmetrically migrates up the shaft of the probe, which means the center of ablation is moving up the shaft during the procedure and the outer margins of the zone of ablation are moving up the shaft as the zone of ablation expands. The NEUWAVE System relies on coherent microwave emissions with at least $\frac{1}{4}$ wavelengths. Because of this, there is no physical ability to shape the ablation zone to alternative shapes using the NEUWAVE™ PR probe or NEUWAVE SYSTEM. Among the ways the invention described herein addresses the PR probe's limitations is by having a stationary center of ablation and eliminating asymmetric ablation pattern migration up the probe while also being able to shape effectively the pattern to fit the desired ablation pattern.

30 **[0227]** U.S. Patent No. 7,611,508 to Yang et al. is discussed in the Background. Yang describes an antenna for microwave tumor ablation that has coaxial antenna conductors surrounded by an insulated sleeve of length and size promoting destructive interference of axial microwave energy passing inside and outside of the sleeve to limit migration of SAR power toward the skin. Yang's floating sleeve provides destructive cancellation or wave interference of the microwaves. Changing the position of the sleeves changes the effective size of the heating pattern as a result of changing the degree of destructive cancellation or wave interference. Yang, operating at 2.45 GHz, would have wavelengths operating at odd multiples of $\frac{1}{2}$ the wavelength, which is $1 * 12.2 \text{ cm} (122.0 \text{ mm}) * 0.5 = 6.1 \text{ cm} (61.0 \text{ mm})$ or longer as higher odd multiples are used. This means that Yang operates using far field radiation regions of the electromagnetic field (EM) surrounding the antenna where microwaves can radiate in a coherent fashion. Among the ways the invention described herein addresses Yang's limitations is by eliminating ablation pattern migration up the probe by having a stationary center of ablation while also being able to effectively shape the pattern to fit the desired ablation pattern.

40 **[0228]** In contrast to the NEUWAVE PR Probe and Yang probe designs, which rely on far field coherent waveform, the ablation probes described herein function in the near field non-radiative (near field reactive) regions of the electromagnetic field (EM) surrounding the antenna where microwaves radiate in a noncoherent fashion. Near field reactive regions are generally considered to be wavelengths of $\lambda/2\pi \sim 0.159$ or less. The ablation probes described herein preferably operate at a wide range of wavelengths, but for soft tissue ablation at 2.45 GHz, the near field reactive aperture would preferably be less than 20.0 mm. For 12 GHz, the wavelength is shorter (e.g. 25.0 mm), which means the aperture and effective antenna length the probe preferably is 4.0 mm or less to provide optimal shaping and centering directed properties. The heat transfer layer 130 described herein is preferably able to take advantage of tissue quenching because there is no coherent waveform being emitted. In sharp contrast, the antenna described in the Yang reference starts with the shortest antenna length of 22.0 mm from the proximal end of the ablation probe and is elongated in increments of $\frac{1}{2}$ wavelengths further up the ablation probe as the floating sleeve is moved further up the shaft (per Yang FIG. 6, the distances labeled with reference numbers 62a, 62b, and 62c) making ablation zone shaping in a space of less than 30.0 mm physically impossible.

Miscellaneous:

55 **[0229]** It is to be understood that the inventions, examples, and embodiments described herein are not limited to

particularly exemplified materials, methods, and/or structures. It is to be understood that the inventions, examples, and embodiments described herein are to be considered preferred inventions, examples, and embodiments whether specifically identified as such or not. The shown inventions, examples, and embodiments are preferred, but are not meant to be limiting unless specifically claimed, in which case they may limit the scope of that particular claim.

5 **[0230]** While the above is a complete description of selected embodiments of the present invention, it is possible to practice the invention using various alternatives, modifications, adaptations, variations, and/or combinations. It will be appreciated by those of ordinary skill in the art that any arrangement that is calculated to achieve the same purpose may be substituted for the specific embodiment shown. It is also to be understood that this description intended to cover all of the generic and specific features of the invention herein described and all statements of the scope of the invention that, as a matter of language, might be said to fall therebetween.

Claims

15 1. An ablation probe tip (100) having a shaft (102) with an insertion end (104), said ablation probe tip (100) receiving ablation means from an ablation source (60), said ablation probe tip (100) for ablating targeted tissue, said ablation probe tip (100) comprising:

(a) said shaft (102) including a coaxial antenna (110);

20 (b) a center of ablation (124) located within said coaxial antenna (110) at least near said insertion end (104);

(c) a heat transfer layer (130) surrounding said coaxial antenna (110), said heat transfer layer (130) spaced from said insertion end (104) such that said center of ablation (124) is between said heat transfer layer (130) and said insertion end (104); and

(d) a thermal reservoir (134) at least partially surrounding said heat transfer layer (130),

25 said thermal reservoir (134) being one of:

a silver thermal reservoir;

an aluminum thermal reservoir;

30 a superconductive thermal reservoir made from at least one superconductive material selected from the group consisting of boron nitride, graphene, graphene nanotubes, and pyrolytic graphite; or

a combination thermal reservoir made from a combination of at least two materials selected from the group consisting of air, water, ice, aluminum, silver, copper, diamond, boron nitride, graphene, graphene nanotubes, and pyrolytic graphite.

35 2. The ablation probe tip (100) of claim 1, said thermal reservoir (134) being a solid thermal reservoir.

3. The ablation probe (100) tip of claim 1, said thermal reservoir (134) forming at least part of a hand piece (52).

40 4. The ablation probe tip (100) of any one of claims 1 to 3, an ablation zone surrounding said center of ablation (124) when said ablation means is provided to said ablation probe tip (100), said thermal reservoir (134) preventing peak temperatures exceed sixty degrees Celsius (60°C) in said ablation zone, or said thermal reservoir (134) preventing peak temperatures exceed forty-five degrees Celsius (45°C) in said ablation zone.

45 5. The ablation probe tip (100) of any one of the preceding claims, said thermal reservoir (134) for passively cooling said heat transfer layer (130) by absorbing heat from said heat transfer layer (130).

50 6. The ablation probe tip (100) of claim 5, an ablation zone surrounding said center of ablation (124) when said ablation means is provided to said ablation probe tip (100), said heat transfer layer (130) and said thermal reservoir (134) providing ablation zone temperature control by keeping peak temperatures below a predetermined temperature in said ablation zone.

55 7. The ablation probe tip (100) of claim 5, an ablation zone surrounding said center of ablation (124) when said ablation means is provided to said ablation probe tip (100), said heat transfer layer (130) and said thermal reservoir (134) providing passive cooling ablation zone temperature control.

8. The ablation probe tip (100) of claim 5, an ablation zone surrounding said center of ablation (124) when said ablation means is provided to said ablation probe tip (100), said heat transfer layer (130) and said thermal reservoir (134)

providing tissue quenching ablation zone temperature control.

- 5 9. The ablation probe tip (100) of claim 5, an ablation zone surrounding said center of ablation (124) when said ablation means is provided to said ablation probe tip (100), said heat transfer layer (130) and said thermal reservoir (134) providing thermal quenching ablation zone temperature control.
10. The ablation probe (100) tip of any one of the preceding claims wherein the heat transfer layer (130) and the thermal reservoir (134) are thermally connected.
- 10 11. The ablation probe tip (100) of claim 10 wherein a heat transfer grease or a thermally conductive epoxy adhesive is provided between the heat transfer layer (130) and the thermal reservoir (134).
12. The ablation probe tip (100) of any one of the preceding claims, further comprising at least one thermal-capacitance-control mechanism for controlling thermal capacitance or capacity of said ablation probe tip (100), said at least one thermal-capacitance-control mechanism comprising
15 means for controlling the temperature of said thermal reservoir (134) by active cooling.
13. The ablation probe tip (100) of any one of the preceding claims, further comprising at least one thermal-capacitance-control mechanism for controlling thermal capacitance or capacity of said ablation probe tip (100), said at least one thermal-capacitance-control mechanism comprising:
20 means for controlling the location of said thermal reservoir (134) by selecting the placement of the thermal reservoir (134) and/or by adjusting the placement of the thermal reservoir (134) by sliding it up or down the shaft.
14. The ablation probe (100) tip of any one of the preceding claims, further comprising at least one thermal-capacitance-control mechanism for controlling thermal capacitance or capacity of said ablation probe tip (100), said at least one thermal-capacitance-control mechanism selected from the group consisting of:
25
- (a) means for controlling the volume of said thermal reservoir (134);
 - (b) means for controlling the cross-sectional area of said heat transfer layer (130);
 - 30 (c) means for controlling the material from which said thermal reservoir (134) is constructed;
 - (d) means for controlling the mass of said heat transfer layer (130);
 - (e) means for controlling the cross-sectional area dimensions of said heat transfer layer (130);
 - (f) means for controlling the volume of said heat transfer layer (130);
 - (g) means for controlling the cross-sectional area of said heat transfer layer (130);
 - 35 (h) means for controlling the material from which said heat transfer layer (130) is constructed;
 - (i) means for controlling power applied to the ablation probe tip (100);
 - (j) means for controlling energy applied to the ablation probe tip (100); and
 - (k) means for controlling duration of an ablation cycle during which heat is applied.

40 **Patentansprüche**

1. Ablationssondenspitze (100) aufweisend einen Schaft (102) mit einem Einführende (104), wobei die Ablationssondenspitze (100) Ablationsmittel von einer Ablationsquelle (60) empfängt, wobei die Ablationssondenspitze (100) zum Abtragen von Zielgewebe dient, wobei die Ablationssondenspitze (100) umfasst:
45
- (a) den Schaft (102) einschließlich einer Koaxialantenne (110);
 - (b) ein Ablationszentrum (124), das sich innerhalb der Koaxialantenne (110) zumindest in der Nähe des Einführendes (104) befindet;
 - 50 (c) eine Wärmeübertragungsschicht (130), die die Koaxialantenne (110) umgibt, wobei die Wärmeübertragungsschicht (130) von dem Einführende (104) so beabstandet ist, dass sich das Ablationszentrum (124) zwischen der Wärmeübertragungsschicht (130) und dem Einführende (104) befindet; und
 - (d) ein Wärmereservoir (134), das die Wärmeübertragungsschicht (130) zumindest teilweise umgibt,
- 55 wobei das Wärmereservoir (134) eines der Folgenden ist:
- ein Wärmereservoir aus Silber;
 - ein Wärmereservoir aus Aluminium;

ein supraleitendes Wärmereservoir aus mindestens einem supraleitenden Material, ausgewählt aus der Gruppe bestehend aus Bornitrid, Graphen, Graphen-Nanoröhren und pyrolytischem Graphit; oder ein kombiniertes Wärmereservoir aus einer Kombination von mindestens zwei Materialien, ausgewählt aus der Gruppe bestehend aus Luft, Wasser, Eis, Aluminium, Silber, Kupfer, Diamant, Bornitrid, Graphen, Graphen-Nanoröhren und pyrolytischem Graphit.

5

2. Ablationssondenspitze (100) nach Anspruch 1, wobei das Wärmereservoir (134) ein festes Wärmereservoir ist.
3. Ablationssondenspitze (100) nach Anspruch 1, wobei das Wärmereservoir (134) zumindest einen Teil eines Handstücks (52) bildet.
4. Ablationssondenspitze (100) nach einem der Ansprüche 1 bis 3, wobei eine Ablationszone das Ablationszentrum (124) umgibt, wenn das Ablationsmittel an der Ablationssondenspitze (100) bereitgestellt ist, wobei das Wärmereservoir (134) verhindert, dass Spitzentemperaturen in der Ablationszone sechzig Grad Celsius (60 °C) überschreiten, oder wobei das Wärmereservoir (134) verhindert, dass Spitzentemperaturen in der Ablationszone fünfundvierzig Grad Celsius (45 °C) überschreiten.
5. Ablationssondenspitze (100) nach einem der vorstehenden Ansprüche, wobei das Wärmereservoir (134) zum passiven Kühlen der Wärmeübertragungsschicht (130) durch Absorbieren von Wärme von der Wärmeübertragungsschicht (130) dient.
6. Ablationssondenspitze (100) nach Anspruch 5, wobei eine Ablationszone das Ablationszentrum (124) umgibt, wenn das Ablationsmittel an der Ablationssondenspitze (100) bereitgestellt ist, wobei die Wärmeübertragungsschicht (130) und das Wärmereservoir (134) eine Temperaturregelung der Ablationszone bereitstellen, indem sie die Spitzentemperaturen in der Ablationszone unter einer vorbestimmten Temperatur halten.
7. Ablationssondenspitze (100) nach Anspruch 5, wobei eine Ablationszone das Ablationszentrum (124) umgibt, wenn das Ablationsmittel an der Ablationssondenspitze (100) bereitgestellt ist, wobei die Wärmeübertragungsschicht (130) und das Wärmereservoir (134) eine passive Kühlung der Ablationszonentemperaturregelung bereitstellen.
8. Ablationssondenspitze (100) nach Anspruch 5, wobei eine Ablationszone das Ablationszentrum (124) umgibt, wenn das Ablationsmittel an der Ablationssondenspitze (100) bereitgestellt ist, wobei die Wärmeübertragungsschicht (130) und das Wärmereservoir (134) eine Temperaturregelung der Ablationszone zur Gewebeabschreckung bereitstellen.
9. Ablationssondenspitze (100) nach Anspruch 5, wobei eine Ablationszone das Ablationszentrum (124) umgibt, wenn das Ablationsmittel an der Ablationssondenspitze (100) bereitgestellt ist, wobei die Wärmeübertragungsschicht (130) und das Wärmereservoir (134) eine Temperaturregelung der Ablationszone zur Wärmeabschreckung bereitstellen.
10. Ablationssondenspitze (100) nach einem der vorstehenden Ansprüche, wobei die Wärmeübertragungsschicht (130) und das Wärmereservoir (134) thermisch verbunden sind.
11. Ablationssondenspitze (100) nach Anspruch 10, wobei zwischen der Wärmeübertragungsschicht (130) und dem Wärmereservoir (134) ein Wärmeübertragungsfett oder ein wärmeleitender Epoxidkleber bereitgestellt ist.
12. Ablationssondenspitze (100) nach einem der vorstehenden Ansprüche, ferner umfassend mindestens einen Wärmekapazitätsregelmechanismus zum Regeln der Wärmekapazität oder Kapazität der Ablationssondenspitze (100) umfasst, wobei der mindestens eine Wärmekapazitätsregelmechanismus umfasst Mittel zum Regeln der Temperatur des Wärmereservoirs (134) durch aktive Kühlung.
13. Ablationssondenspitze (100) nach einem der vorstehenden Ansprüche, ferner umfassend mindestens einen Wärmekapazitätsregelmechanismus zum Regeln der Wärmekapazität oder Kapazität der Ablationssondenspitze (100), wobei der mindestens eine Wärmekapazitätsregelmechanismus umfasst: Mittel zum Regeln der Position des Wärmereservoirs (134) durch Auswählen der Platzierung des Wärmereservoirs (134) und/oder durch Anpassen der Platzierung des Wärmereservoirs (134), indem es entlang des Schafts nach oben oder unten geschoben wird.

10

15

20

25

30

35

40

45

50

55

14. Ablationssondenspitze (100) nach einem der vorstehenden Ansprüche, ferner umfassend mindestens einen Wärmekapazitätsregelmechanismus zum Regeln der Wärmekapazität oder Kapazität der Ablationssondenspitze (100), wobei der mindestens eine Wärmekapazitätsregelmechanismus ausgewählt ist aus der Gruppe bestehend aus:

- 5 (a) Mittel zum Regeln des Volumens des Wärmereservoirs (134);
- (b) Mittel zum Regeln der Querschnittsfläche der Wärmeübertragungsschicht (130);
- (c) Mittel zum Steuern des Materials, aus dem das Wärmereservoir (134) aufgebaut ist;
- (d) Mittel zum Regeln der Masse der Wärmeübertragungsschicht (130);
- 10 (e) Mittel zum Regeln der Querschnittsflächenabmessungen der Wärmeübertragungsschicht (130);
- (f) Mittel zum Regeln des Volumens der Wärmeübertragungsschicht (130);
- (g) Mittel zum Regeln der Querschnittsfläche der Wärmeübertragungsschicht (130);
- (h) Mittel zum Regeln des Materials, aus dem die Wärmeübertragungsschicht (130) aufgebaut ist;
- (i) Mittel zum Regeln der an die Ablationssondenspitze (100) angelegten Leistung;
- (j) Mittel zum Regeln der an die Ablationssondenspitze (100) angelegten Energie; und
- 15 (k) Mittel zum Regeln der Dauer eines Ablationszyklus, während dem Wärme angewendet wird.

Revendications

20 1. Pointe de sonde d'ablation (100) ayant un arbre (102) doté d'une extrémité d'insertion (104), ladite pointe de sonde d'ablation (100) recevant un moyen d'ablation à partir d'une source d'ablation (60), ladite pointe de sonde d'ablation (100) permettant de réaliser l'ablation d'un tissu ciblé, ladite pointe de sonde d'ablation (100) comprenant :

- 25 (a) ledit arbre (102) comportant une antenne coaxiale (110) ;
- (b) un centre d'ablation (124) situé au sein de ladite antenne coaxiale (110) au moins à proximité de ladite extrémité d'insertion (104) ;
- (c) une couche de transfert de chaleur (130) entourant ladite antenne coaxiale (110), ladite couche de transfert de chaleur (130) étant espacée de ladite extrémité d'insertion (104) de telle sorte que ledit centre d'ablation (124) se trouve entre ladite couche de transfert de chaleur (130) et ladite extrémité d'insertion (104) ; et
- 30 (d) un réservoir thermique (134) entourant au moins partiellement ladite couche de transfert de chaleur (130),

ledit réservoir thermique (134) est l'un parmi :

- 35 un réservoir thermique en argent ;
- un réservoir thermique en aluminium ;
- un réservoir thermique supraconducteur constitué à partir d'au moins un matériau supraconducteur choisi dans le groupe constitué de nitrure de bore, de graphène, de nanotubes de graphène et de graphite pyrolytique ; ou
- un réservoir thermique de combinaison constitué à partir d'une combinaison d'au moins deux matériaux choisis dans le groupe constitué d'air, d'eau, de glace, d'aluminium, d'argent, de cuivre, de diamant, de nitrure de bore,
- 40 de graphène, de nanotubes de graphène et de graphite pyrolytique.

2. Pointe de sonde d'ablation (100) selon la revendication 1, ledit réservoir thermique (134) étant un réservoir thermique solide.

45 3. Pointe de sonde d'ablation (100) selon la revendication 1, ledit réservoir thermique (134) formant au moins une partie d'une pièce à main (52).

4. Pointe de sonde d'ablation (100) selon l'une quelconque des revendications 1 à 3, une zone d'ablation entourant ledit centre d'ablation (124) lorsque ledit moyen d'ablation est fourni à ladite pointe de sonde d'ablation (100), ledit réservoir thermique (134) empêchant les températures maximales de dépasser soixante degrés Celsius (60 °C) dans ladite zone d'ablation, ou ledit réservoir thermique (134) empêchant les températures maximales de dépasser quarante-cinq degrés Celsius (45 °C) dans ladite zone d'ablation.

5. Pointe de sonde d'ablation (100) selon l'une quelconque des revendications précédentes, ledit réservoir thermique (134) permettant de refroidir passivement ladite couche de transfert de chaleur (130) en absorbant de la chaleur à partir de ladite couche de transfert de chaleur (130).

6. Pointe de sonde d'ablation (100) selon la revendication 5, une zone d'ablation entourant ledit centre d'ablation (124)

EP 4 231 953 B1

lorsque ledit moyen d'ablation est fourni à ladite pointe de sonde d'ablation (100), ladite couche de transfert de chaleur (130) et ledit réservoir thermique (134) fournissant la commande de la température de zone d'ablation en maintenant les températures maximales en dessous d'une température prédéterminée dans ladite zone d'ablation.

- 5 7. Pointe de sonde d'ablation (100) selon la revendication 5, une zone d'ablation entourant ledit centre d'ablation (124) lorsque ledit moyen d'ablation est fourni à ladite pointe de sonde d'ablation (100), ladite couche de transfert de chaleur (130) et ledit réservoir thermique (134) fournissant une commande de température de zone d'ablation de refroidissement passif.
- 10 8. Pointe de sonde d'ablation (100) selon la revendication 5, une zone d'ablation entourant ledit centre d'ablation (124) lorsque ledit moyen d'ablation est fourni à ladite pointe de sonde d'ablation (100), ladite couche de transfert de chaleur (130) et ledit réservoir thermique (134) fournissant la commande de température de zone d'ablation de trempe de tissu.
- 15 9. Pointe de sonde d'ablation (100) selon la revendication 5, une zone d'ablation entourant ledit centre d'ablation (124) lorsque ledit moyen d'ablation est fourni à ladite pointe de sonde d'ablation (100), ladite couche de transfert de chaleur (130) et ledit réservoir thermique (134) fournissant la commande de température de zone d'ablation de trempe thermique.
- 20 10. Pointe de sonde d'ablation (100) selon l'une quelconque des revendications précédentes, dans laquelle la couche de transfert de chaleur (130) et le réservoir thermique (134) sont reliés thermiquement.
- 25 11. Pointe de sonde d'ablation (100) selon la revendication 10 dans laquelle une graisse de transfert de chaleur ou un adhésif époxy thermoconducteur est prévu entre la couche de transfert de chaleur (130) et le réservoir thermique (134).
- 30 12. Pointe de sonde d'ablation (100) selon l'une quelconque des revendications précédentes, comprenant en outre au moins un mécanisme de commande de capacitance thermique pour commander la capacitance thermique ou la capacité de ladite pointe de sonde d'ablation (100), ledit au moins un mécanisme de commande de capacitance thermique comprenant un moyen de commande de la température dudit réservoir thermique (134) par refroidissement actif.
- 35 13. Pointe de sonde d'ablation (100) selon l'une quelconque des revendications précédentes, comprenant en outre au moins un mécanisme de commande de capacitance thermique pour commander la capacitance thermique ou la capacité de ladite pointe de sonde d'ablation (100), ledit au moins un mécanisme de commande de capacitance thermique comprenant : un moyen de commande de l'emplacement dudit réservoir thermique (134) en sélectionnant le placement du réservoir thermique (134) et/ou en ajustant le placement du réservoir thermique (134) en le faisant glisser en haut ou en bas de l'arbre.
- 40 14. Pointe de sonde d'ablation (100) selon l'une quelconque des revendications précédentes, comprenant en outre au moins un mécanisme de commande de capacitance thermique pour commander la capacitance thermique ou la capacité de ladite pointe de sonde d'ablation (100), ledit au moins un mécanisme de commande de capacitance thermique étant choisi dans le groupe constitué par :
- 45 (a) un moyen de commande du volume dudit réservoir thermique (134) ;
(b) un moyen de commande de la section transversale de ladite couche de transfert de chaleur (130) ;
(c) un moyen de commande du matériau à partir duquel ledit réservoir thermique (134) est construit ;
(d) un moyen de commande de la masse de ladite couche de transfert de chaleur (130) ;
50 (e) un moyen de commande des dimensions de section transversale de ladite couche de transfert de chaleur (130) ;
(f) un moyen de commande du volume de ladite couche de transfert de chaleur (130) ;
(g) un moyen de commande de la section transversale de ladite couche de transfert de chaleur (130) ;
(h) un moyen de commande du matériau à partir duquel ladite couche de transfert de chaleur (130) est construite ;
55 (i) un moyen de commande de la puissance appliquée à la pointe de sonde d'ablation (100) ;
(j) un moyen de commande de l'énergie appliquée à la pointe de sonde d'ablation (100) ; et
(k) un moyen de commande de la durée d'un cycle d'ablation au cours duquel de la chaleur est appliquée.

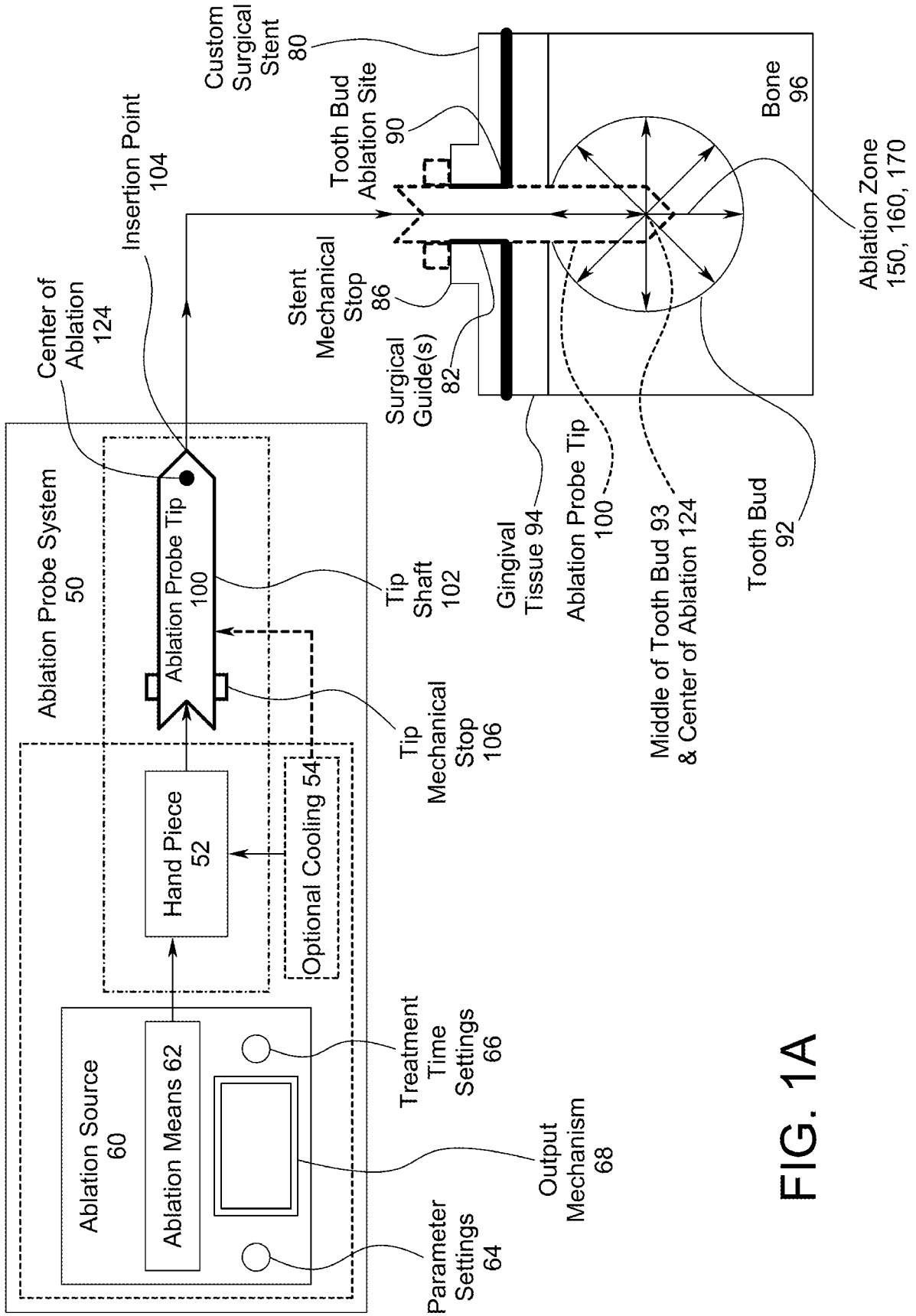

FIG. 1A

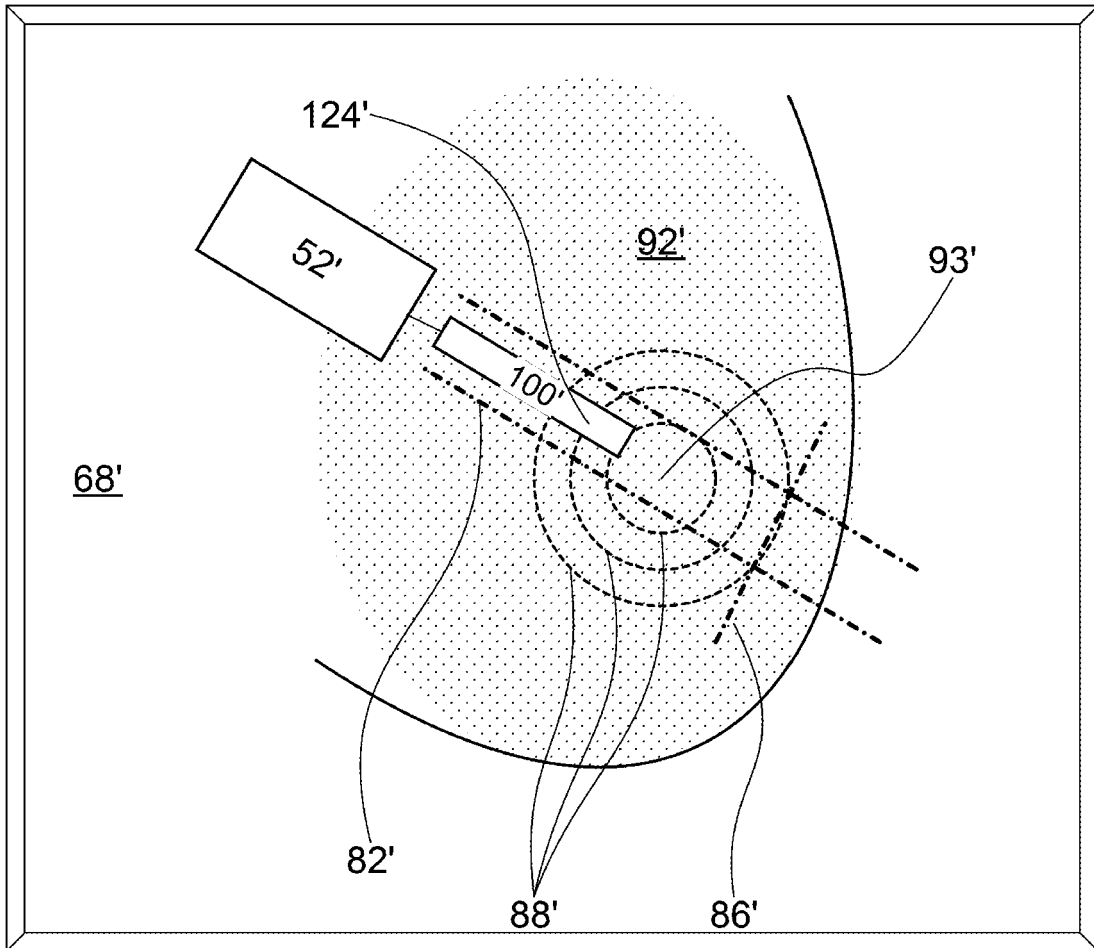

FIG. 1B

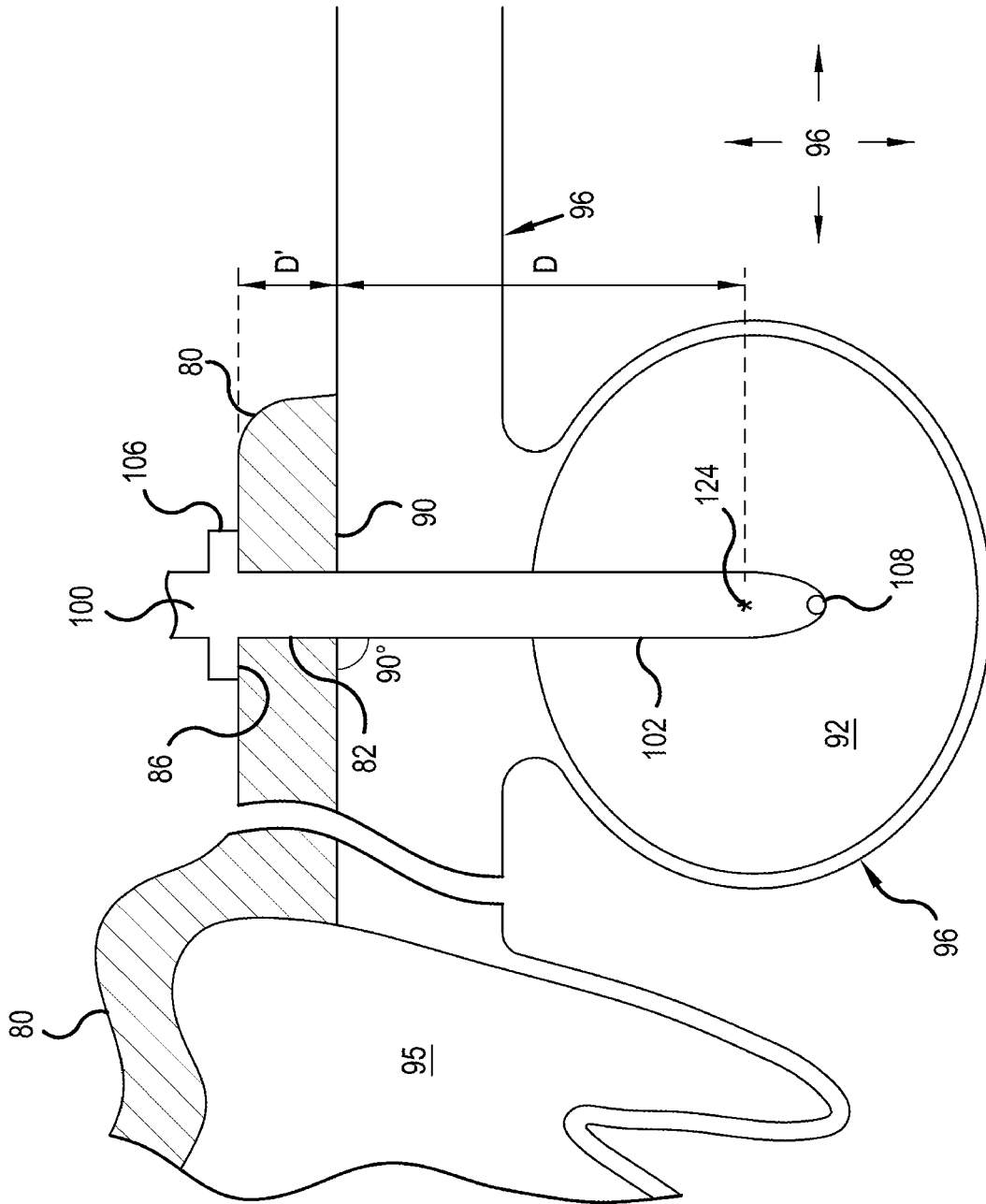

FIG. 2

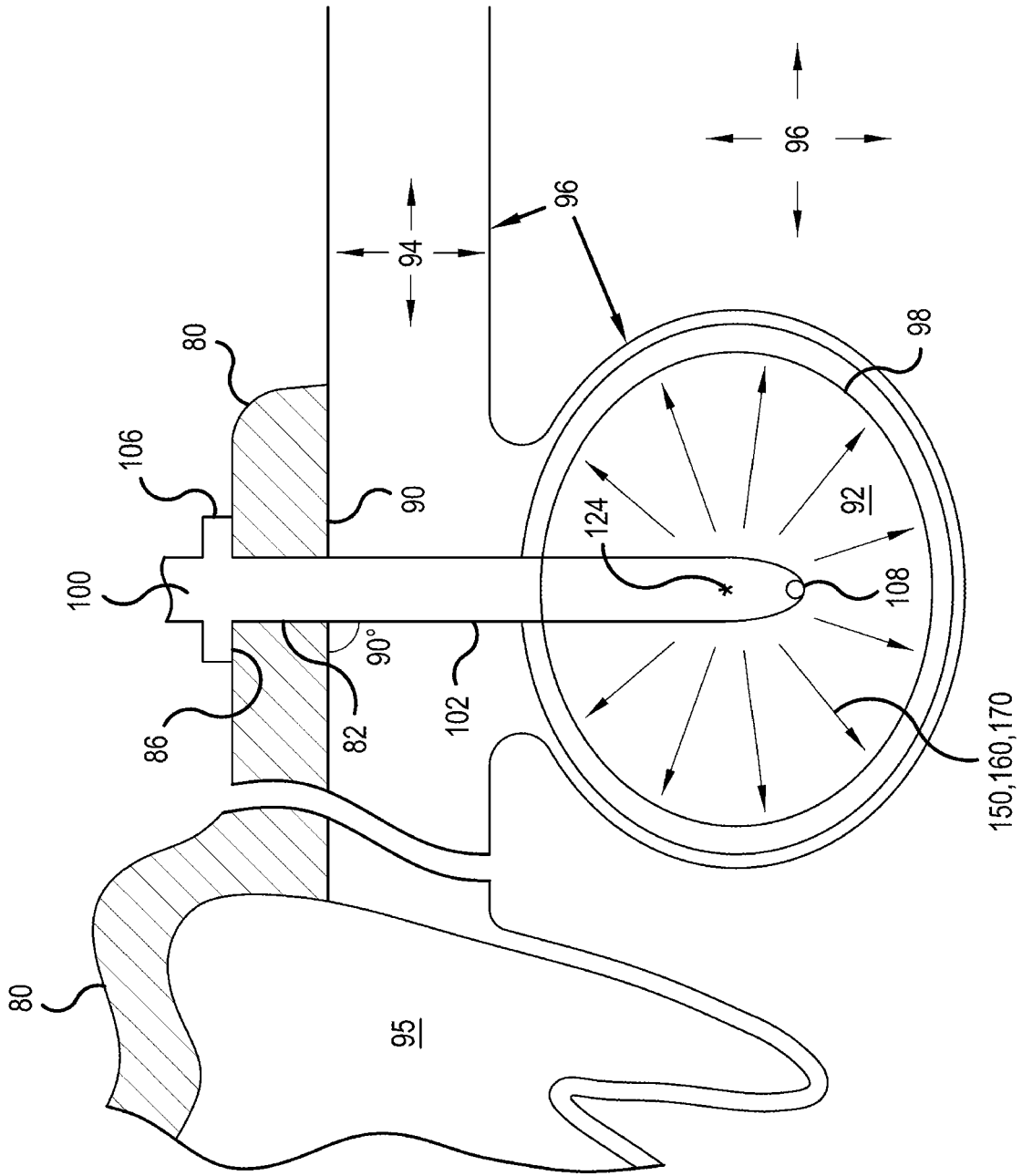

FIG. 3

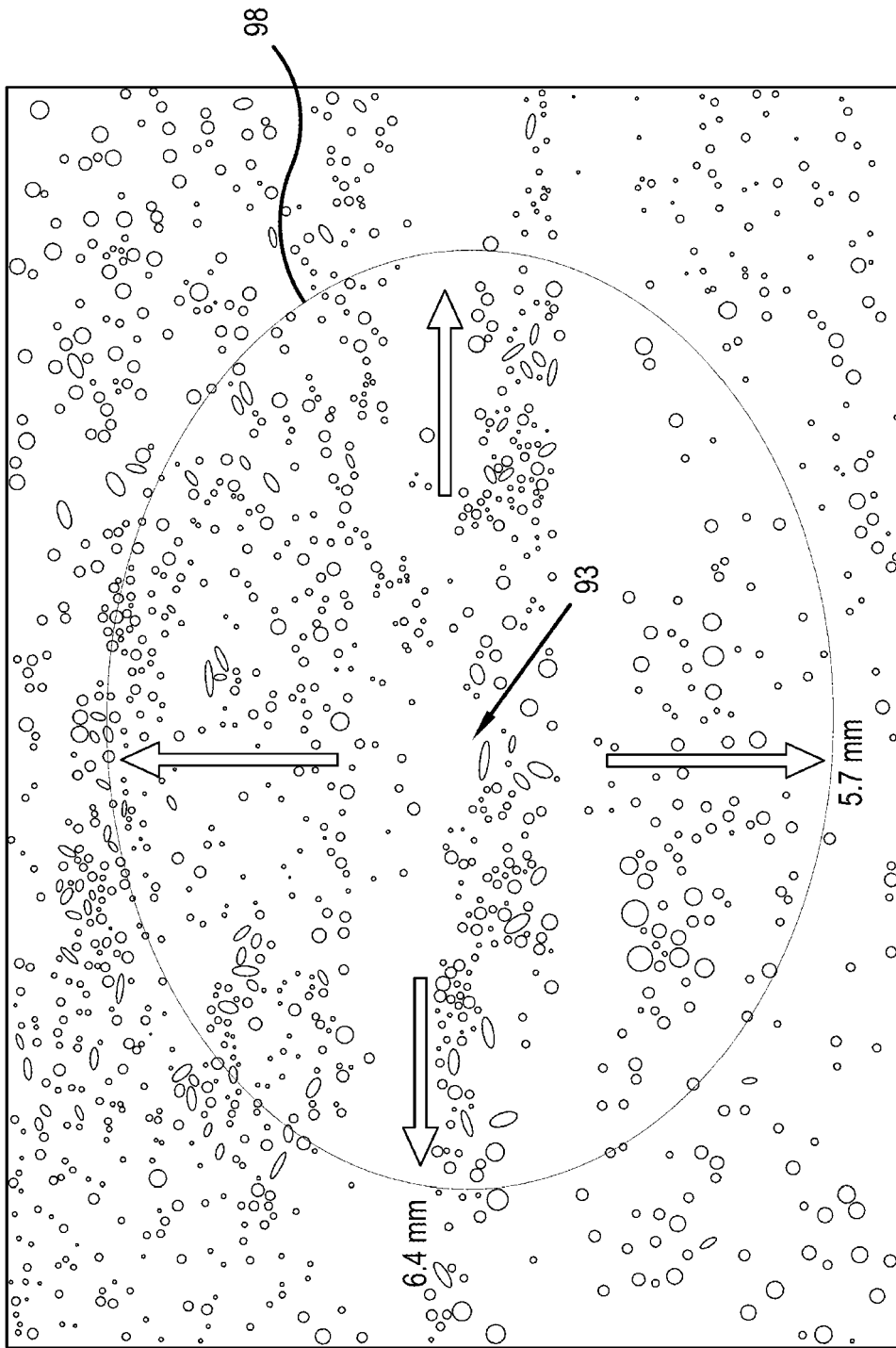

FIG. 4

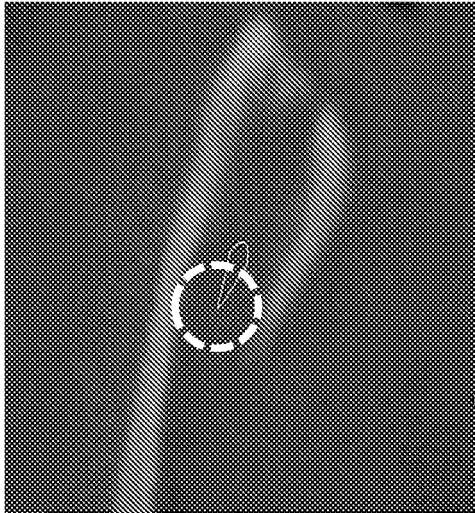

FIG. 5

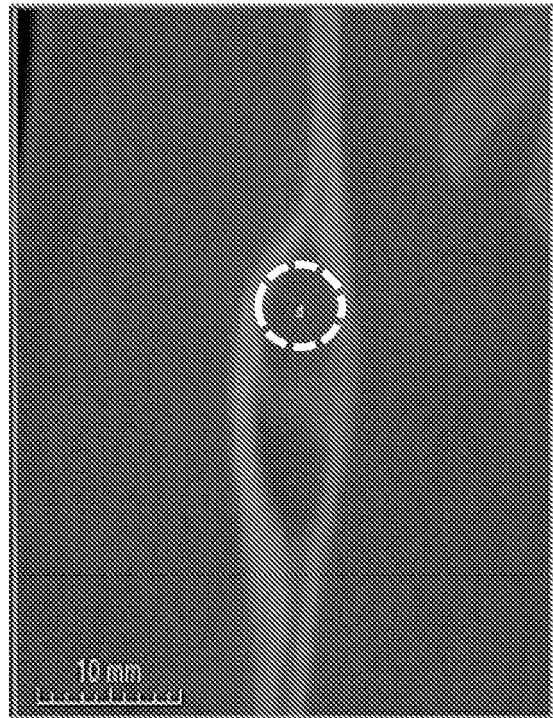

FIG. 6

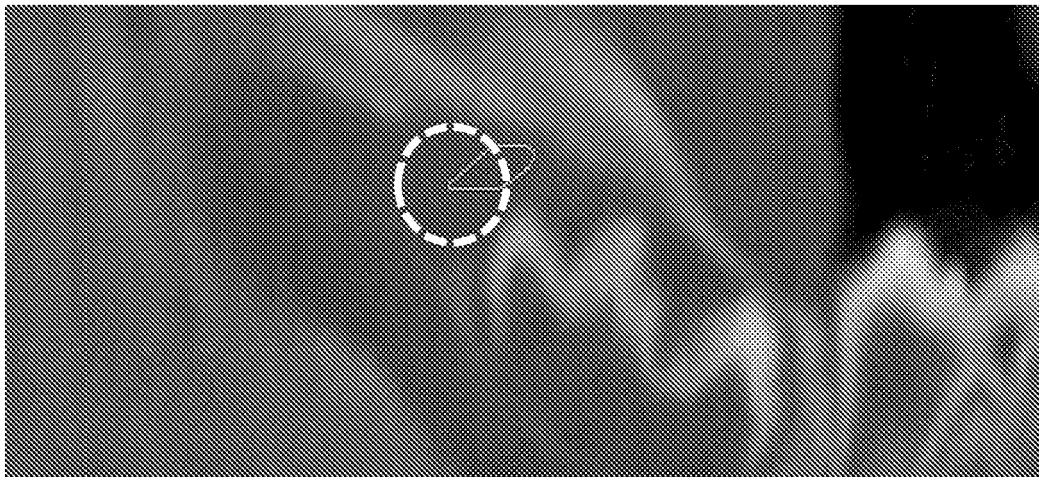

FIG. 7

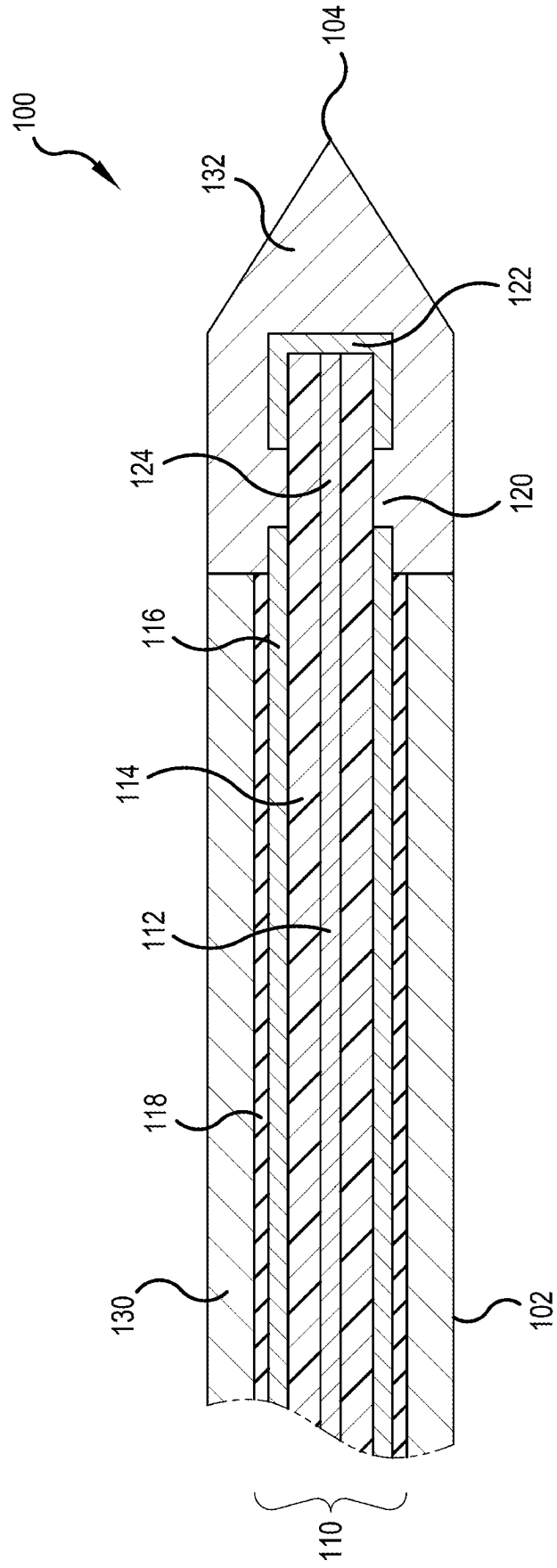

FIG. 8

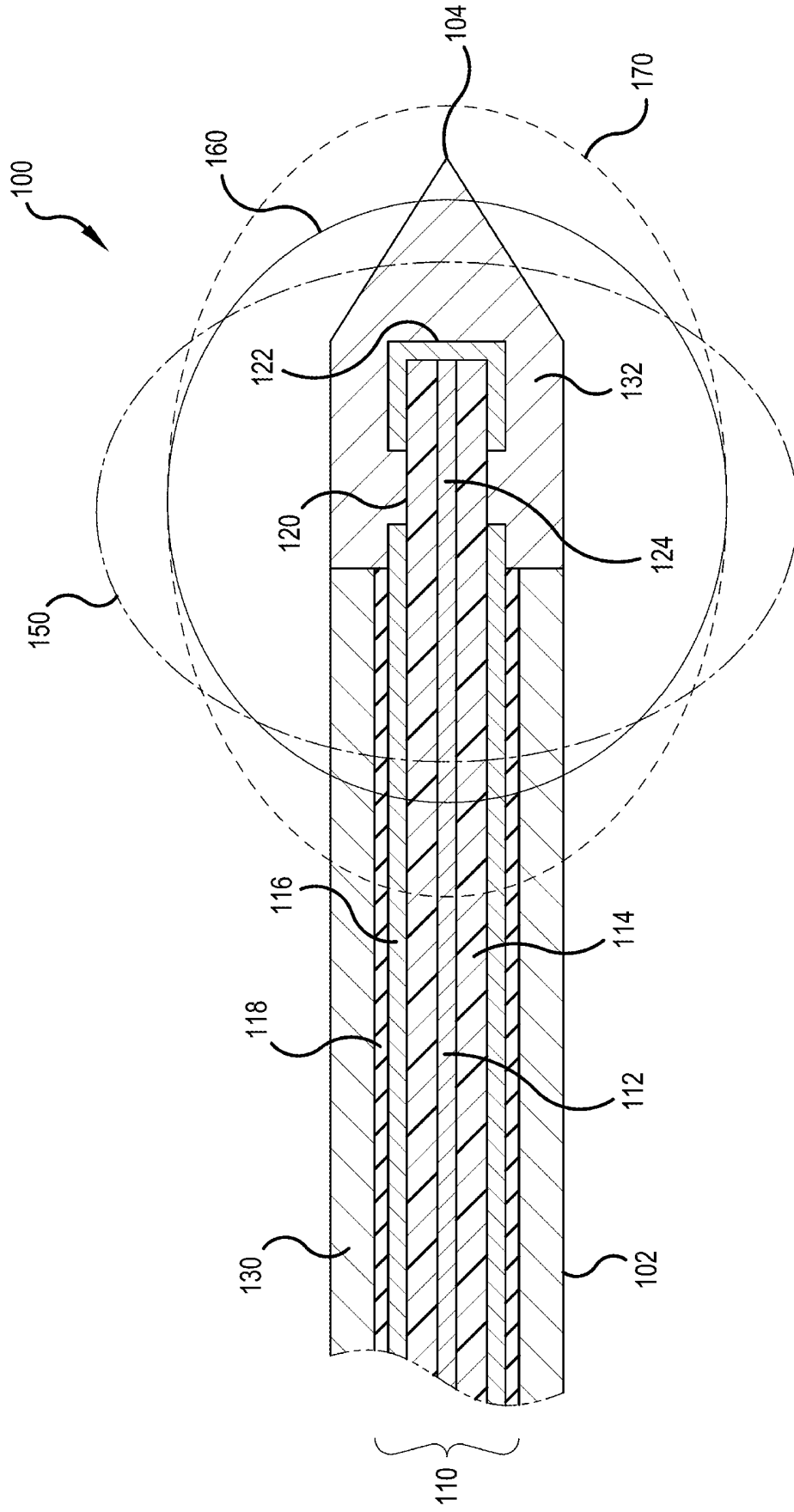

FIG. 9

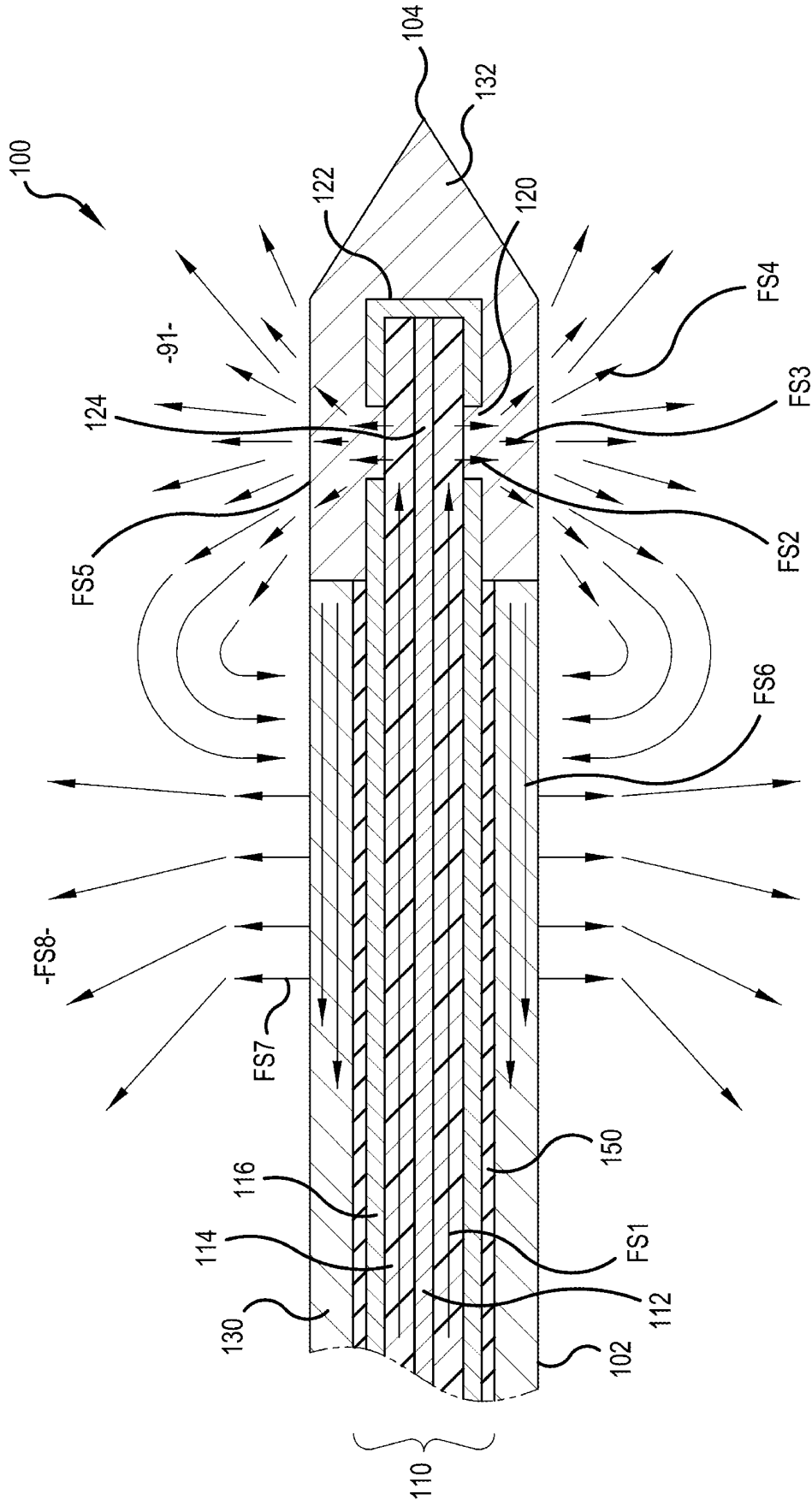

FIG. 10

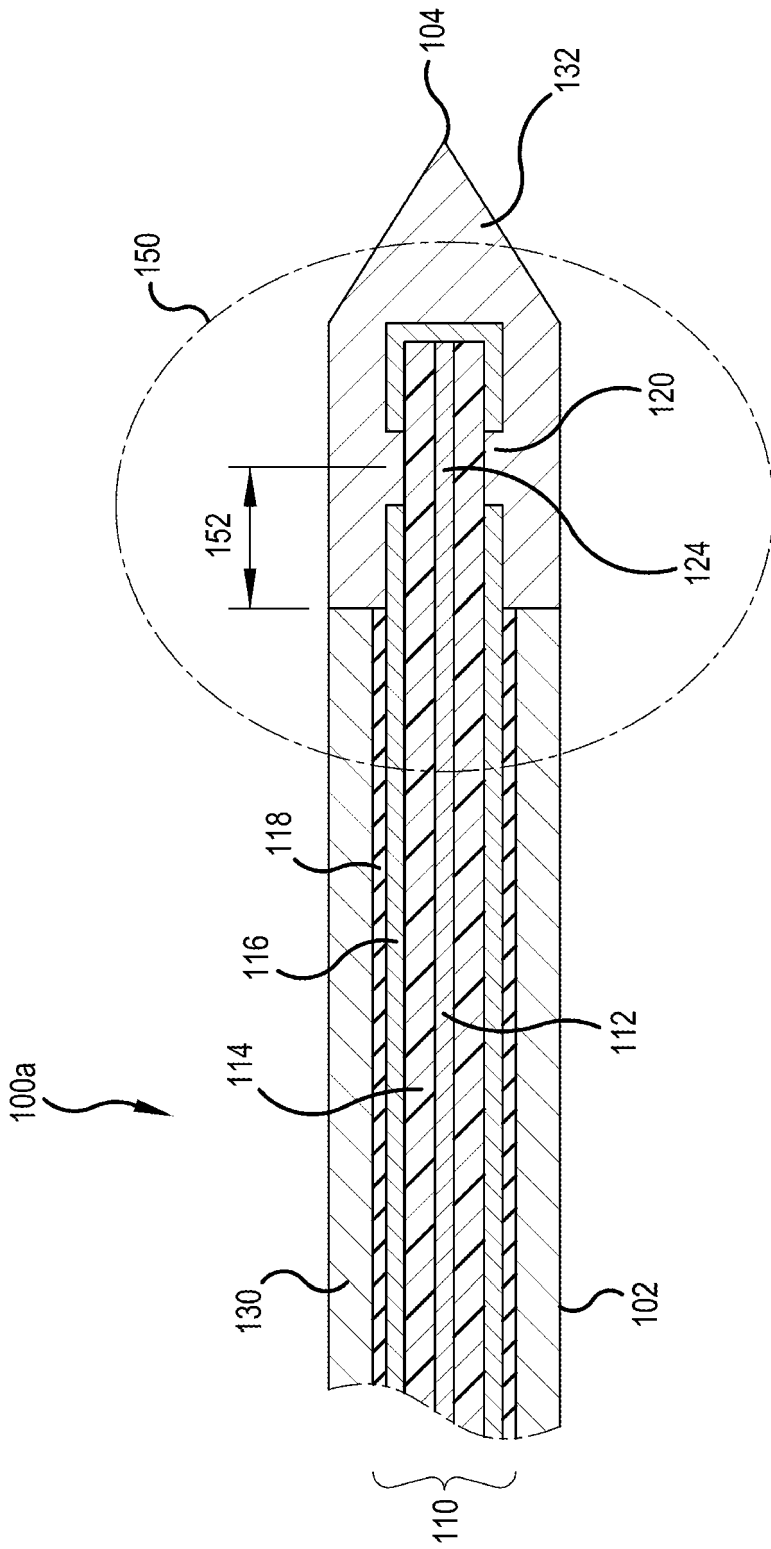

FIG. 11

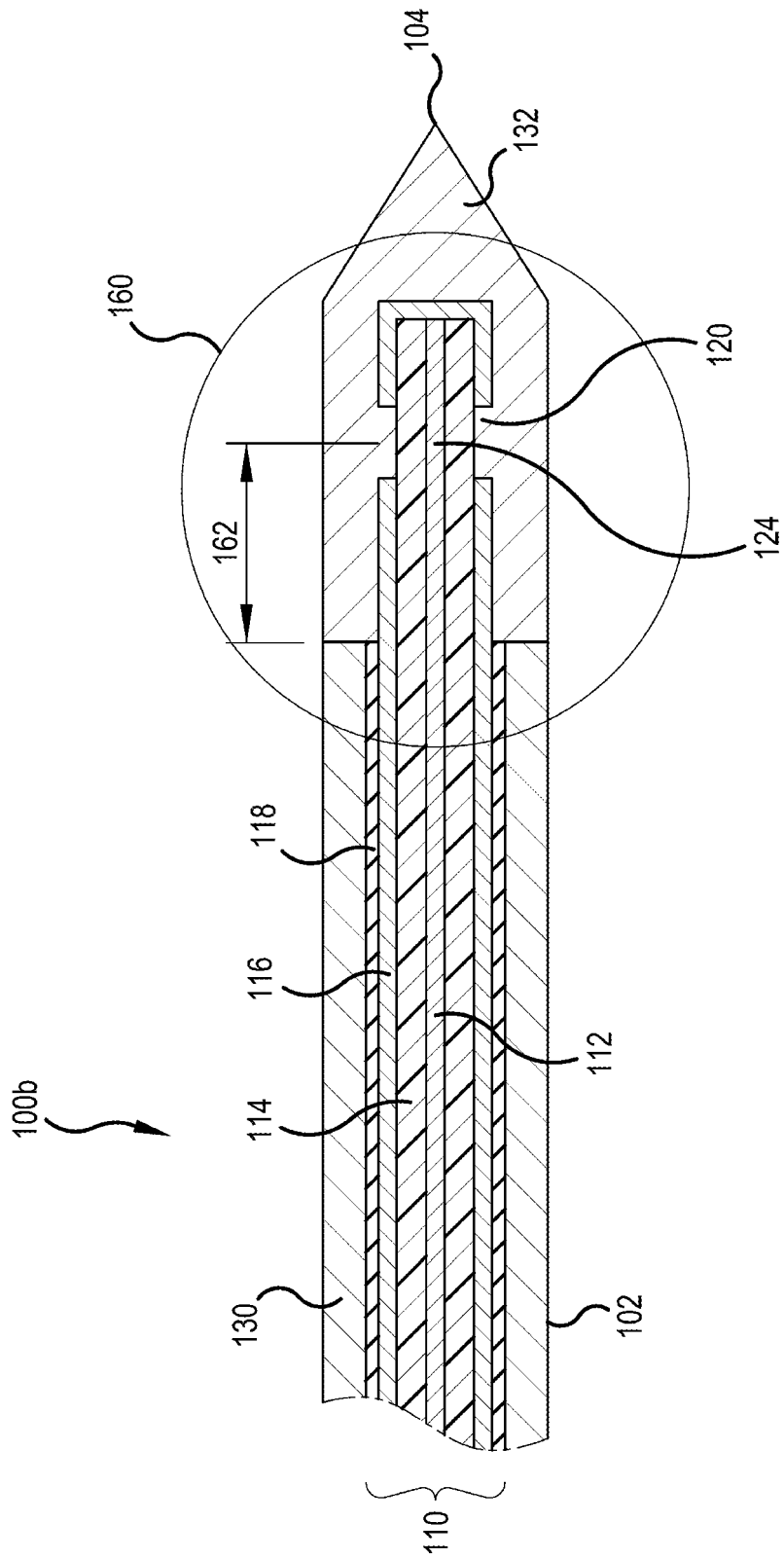

FIG. 12

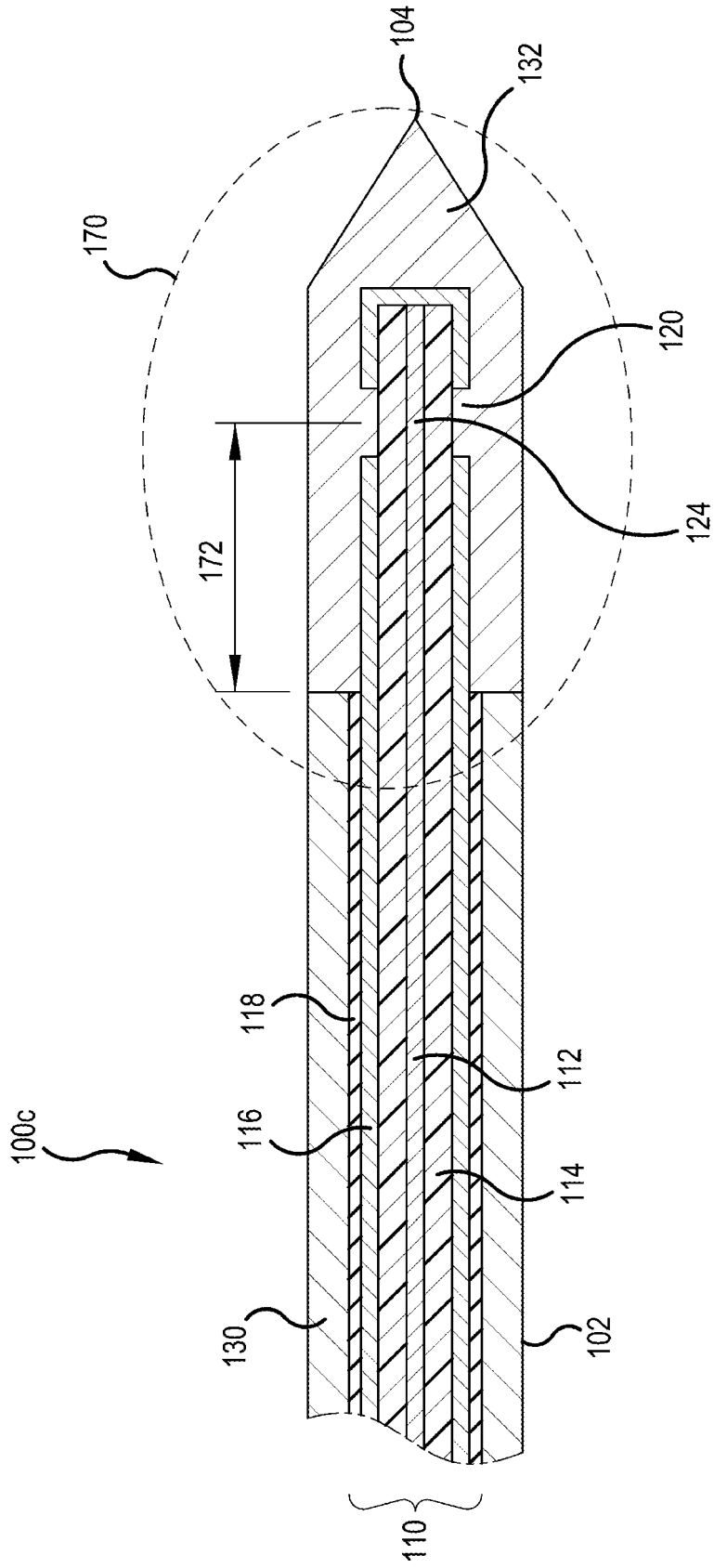

FIG. 13

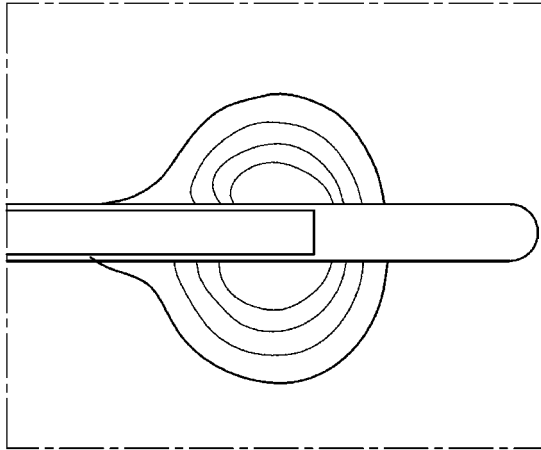

FIG. 14A

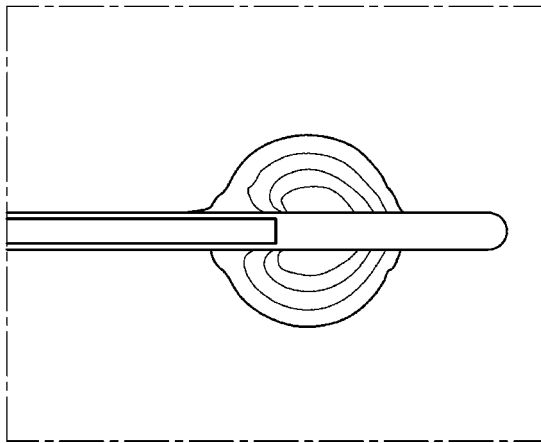

FIG. 14B

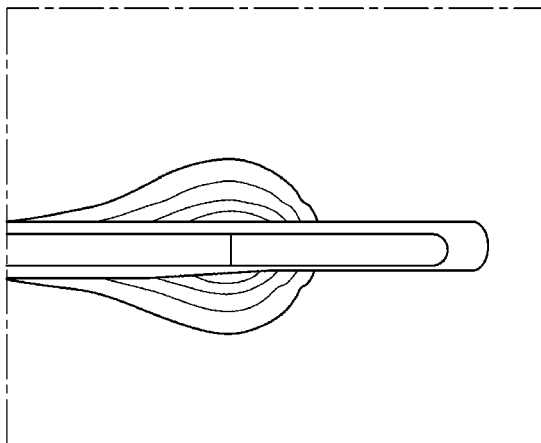

FIG. 14C

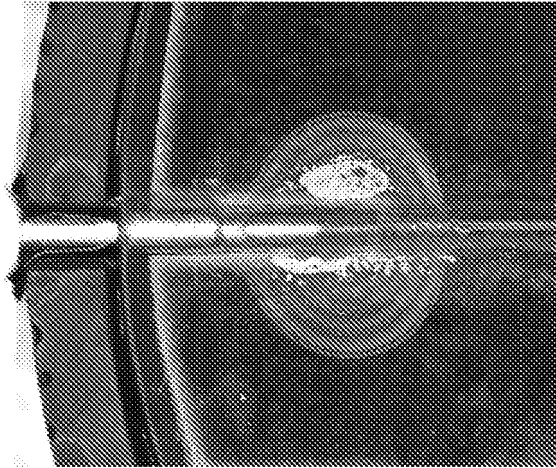

FIG. 15A

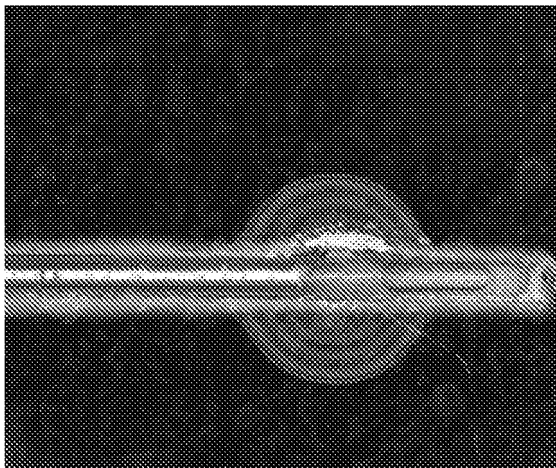

FIG. 15B

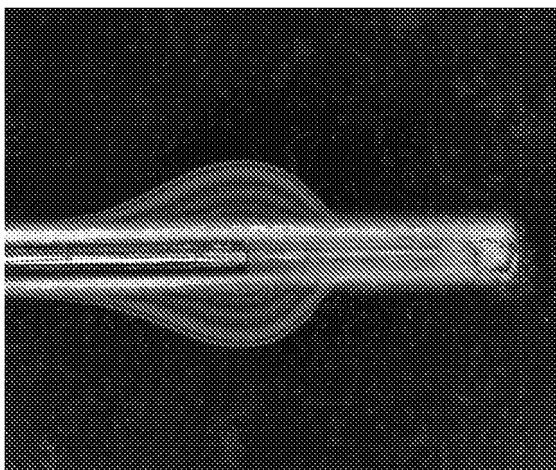

FIG. 15C

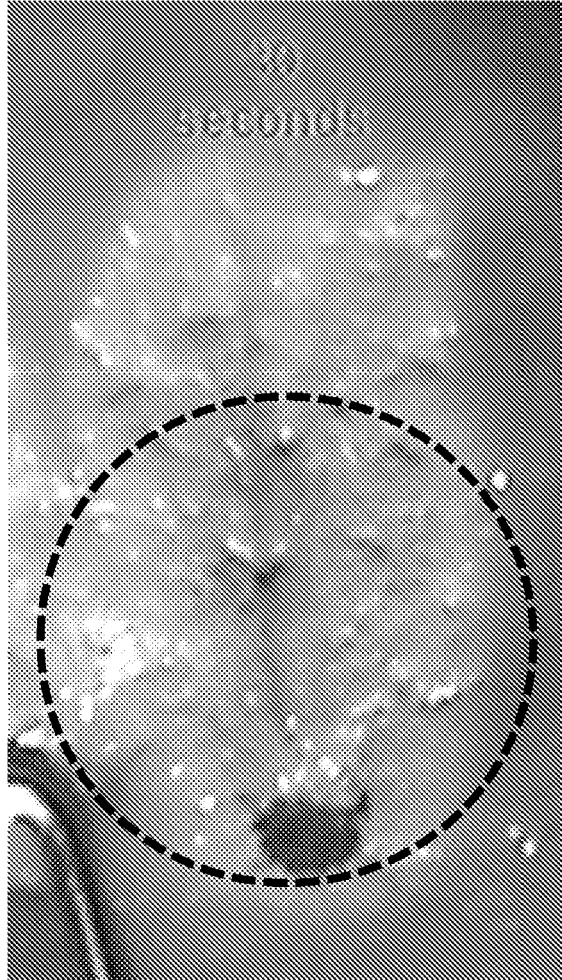

FIG. 16A

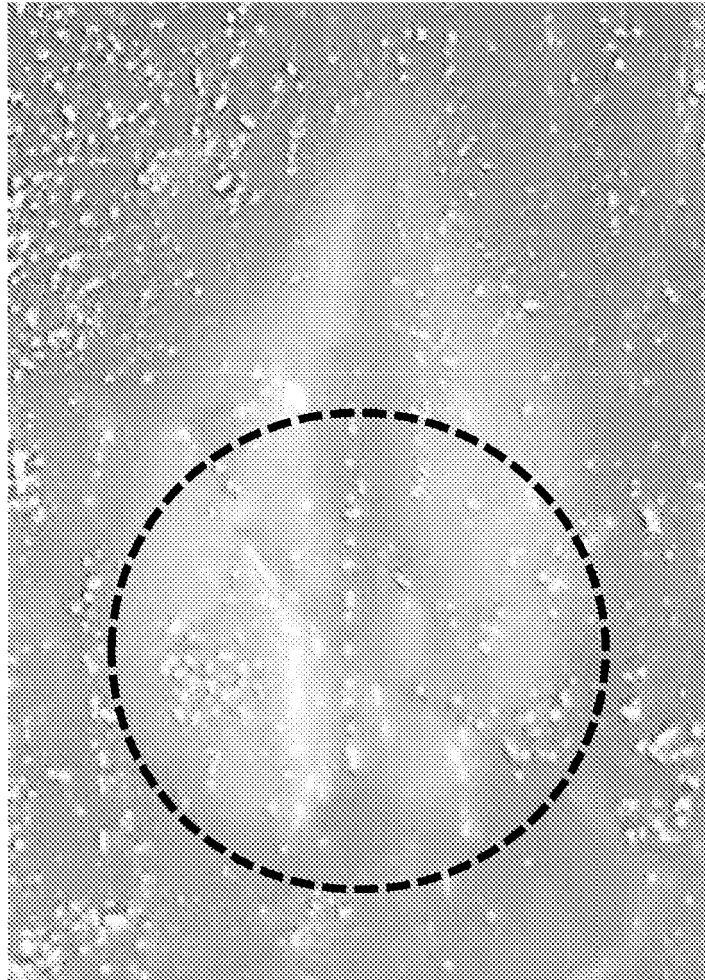

FIG. 16B

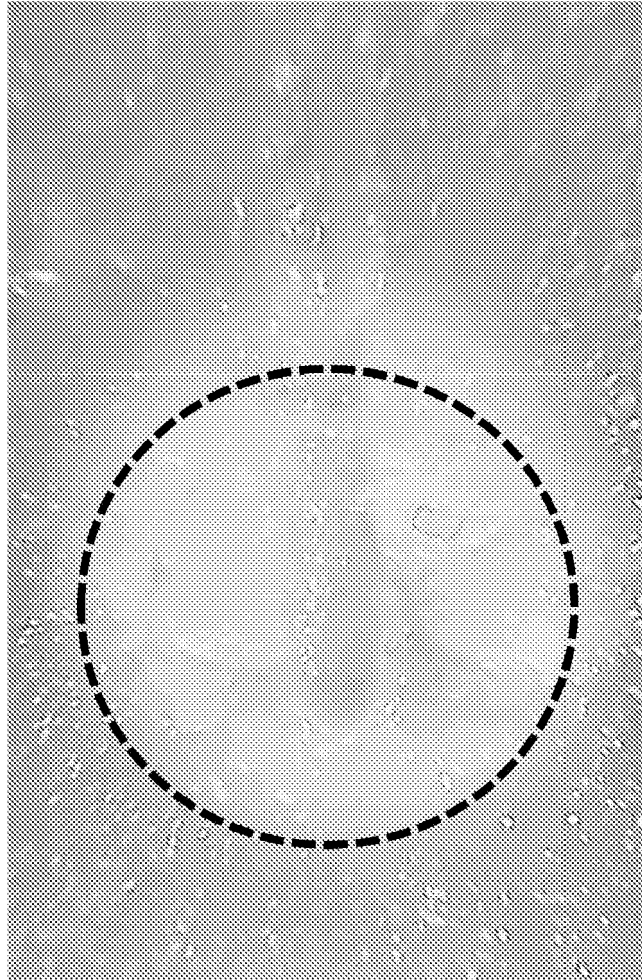

FIG. 16C

The data is fit to the following model:

$$R = \beta_0 + \beta_1 T + \beta_2 A + \beta_{12} TA + \varepsilon$$

Where:

R = 60C Contour Roundness (Width/Length)

T = Thermal Conductivity (W/mK at 0C)

A = Probe Aperture (mm)

ε = error

Source	Log Worth	PValue
Thermal Conductivity (W/mK at 0C)	11.844	0.00000
Aperture (mm)	3.470	0.00034
Thermal Conductivity (W/mK at 0C)*Aperture (mm)	0.960	0.10958

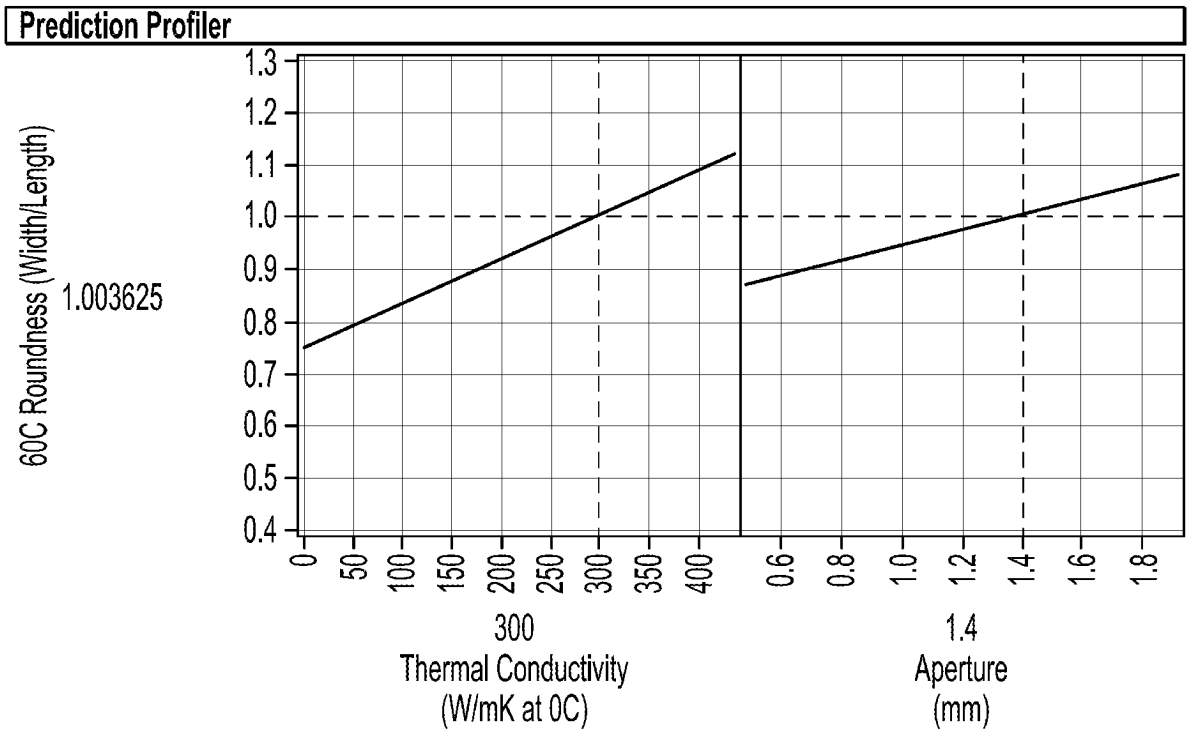

FIG. 17

$Area = \beta_0 + \beta_1 t + \beta_2 p + \beta_{12} tp + \beta_{11} t^2 + \varepsilon$
 where t is time and p is power. The model results are shown in the figure below.

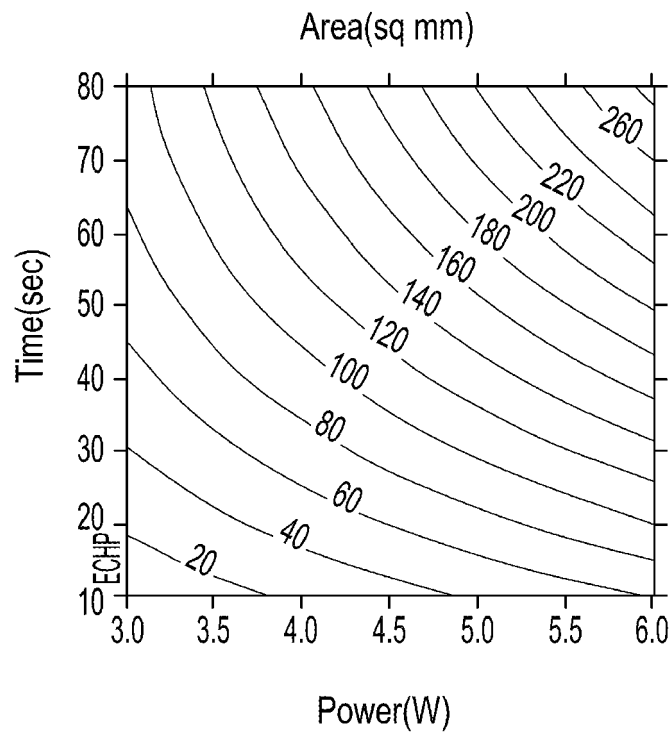

FIG. 18

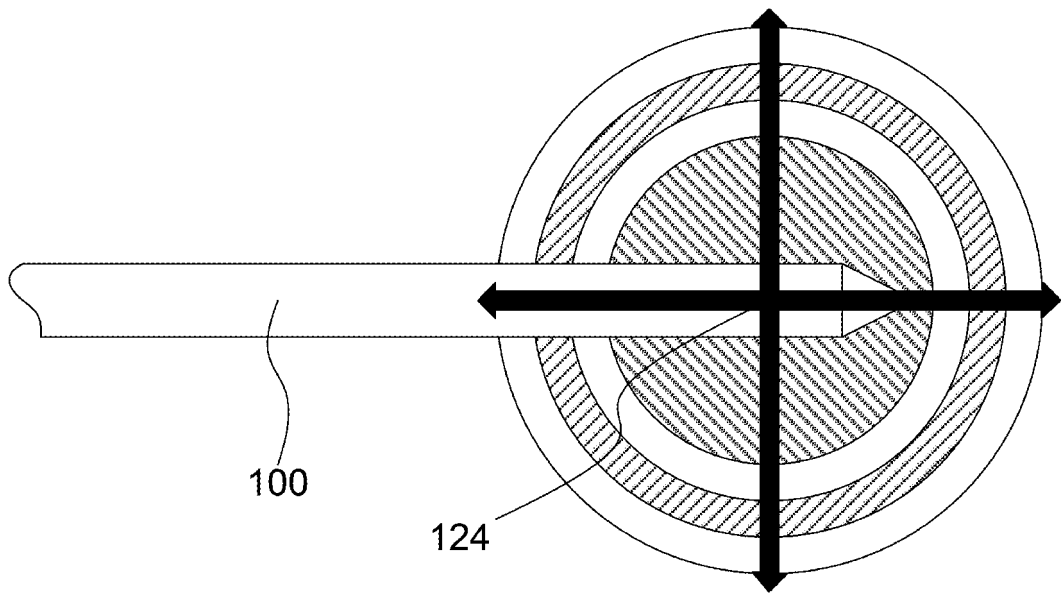

FIG. 19

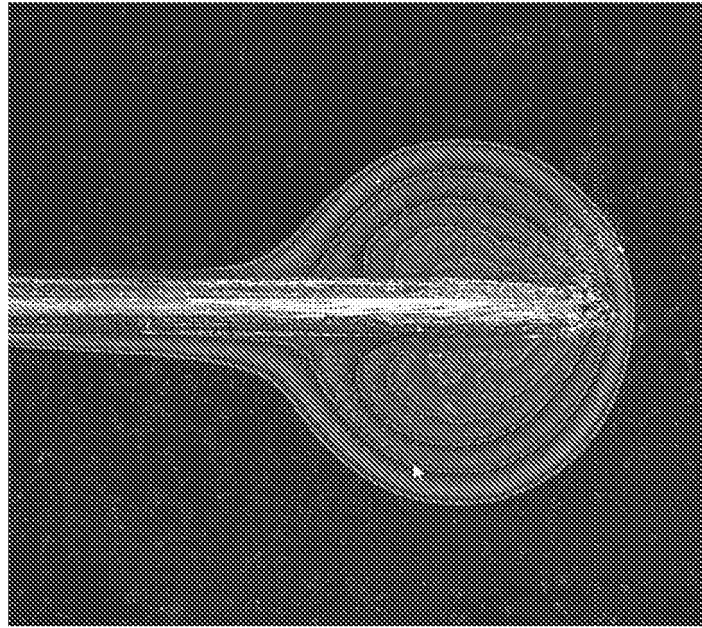

FIG. 20A

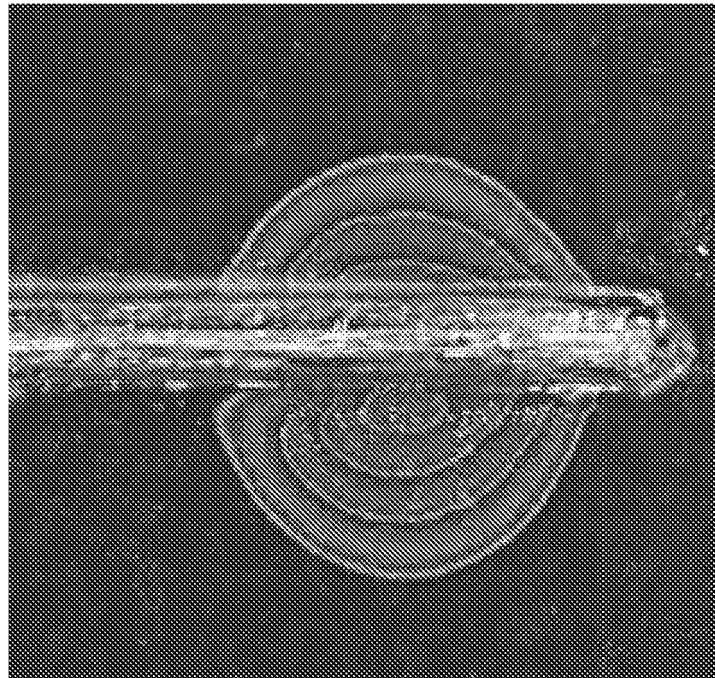

FIG. 20B

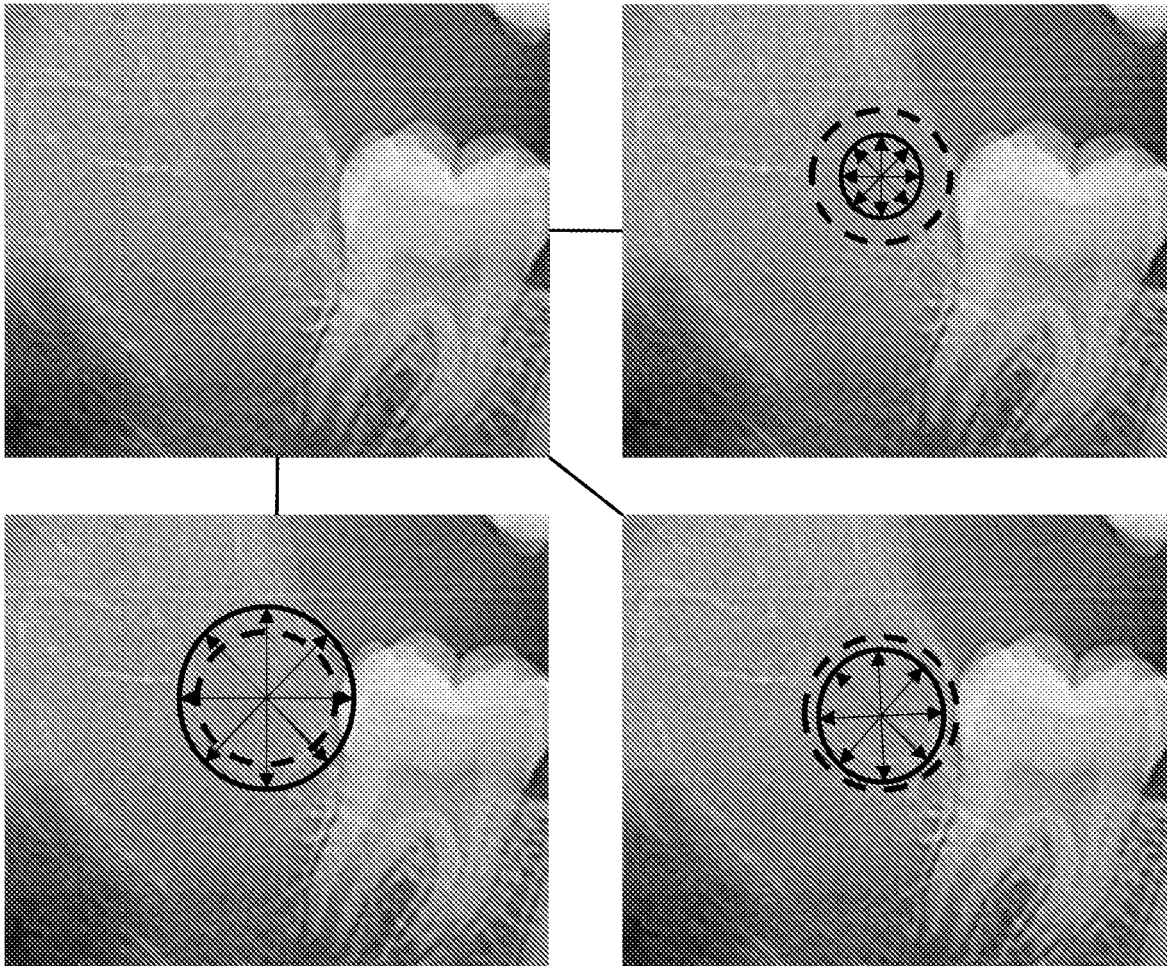

FIG. 21

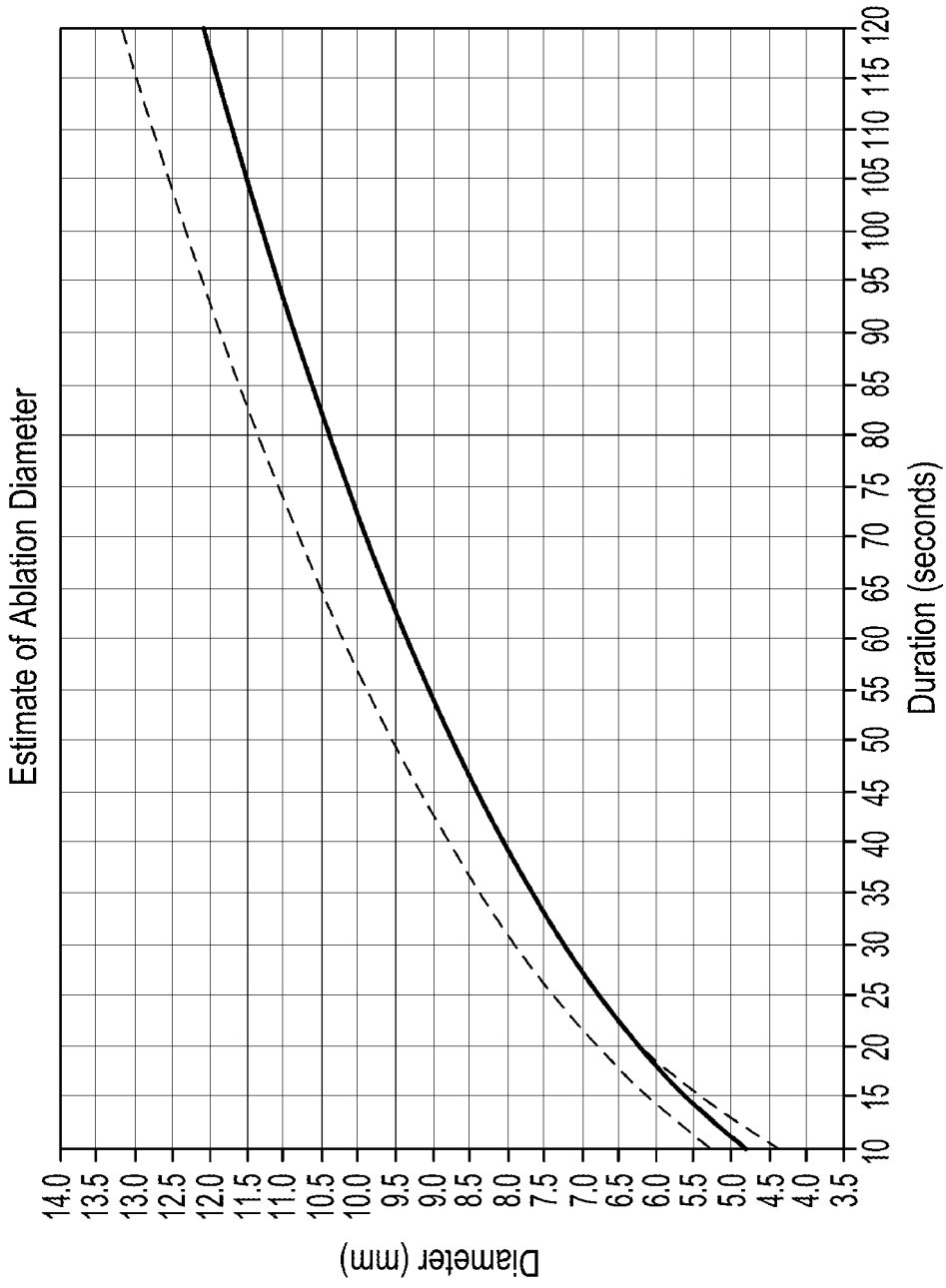

FIG. 22

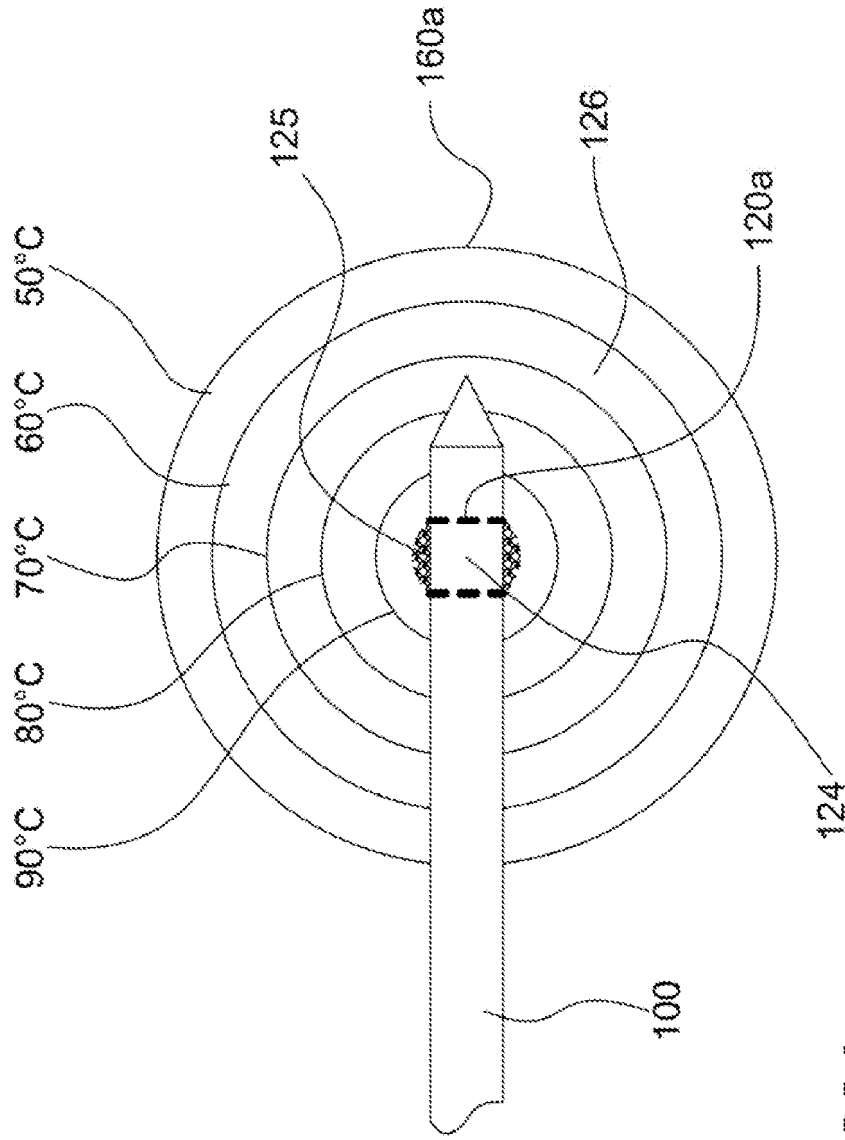

FIG. 23A

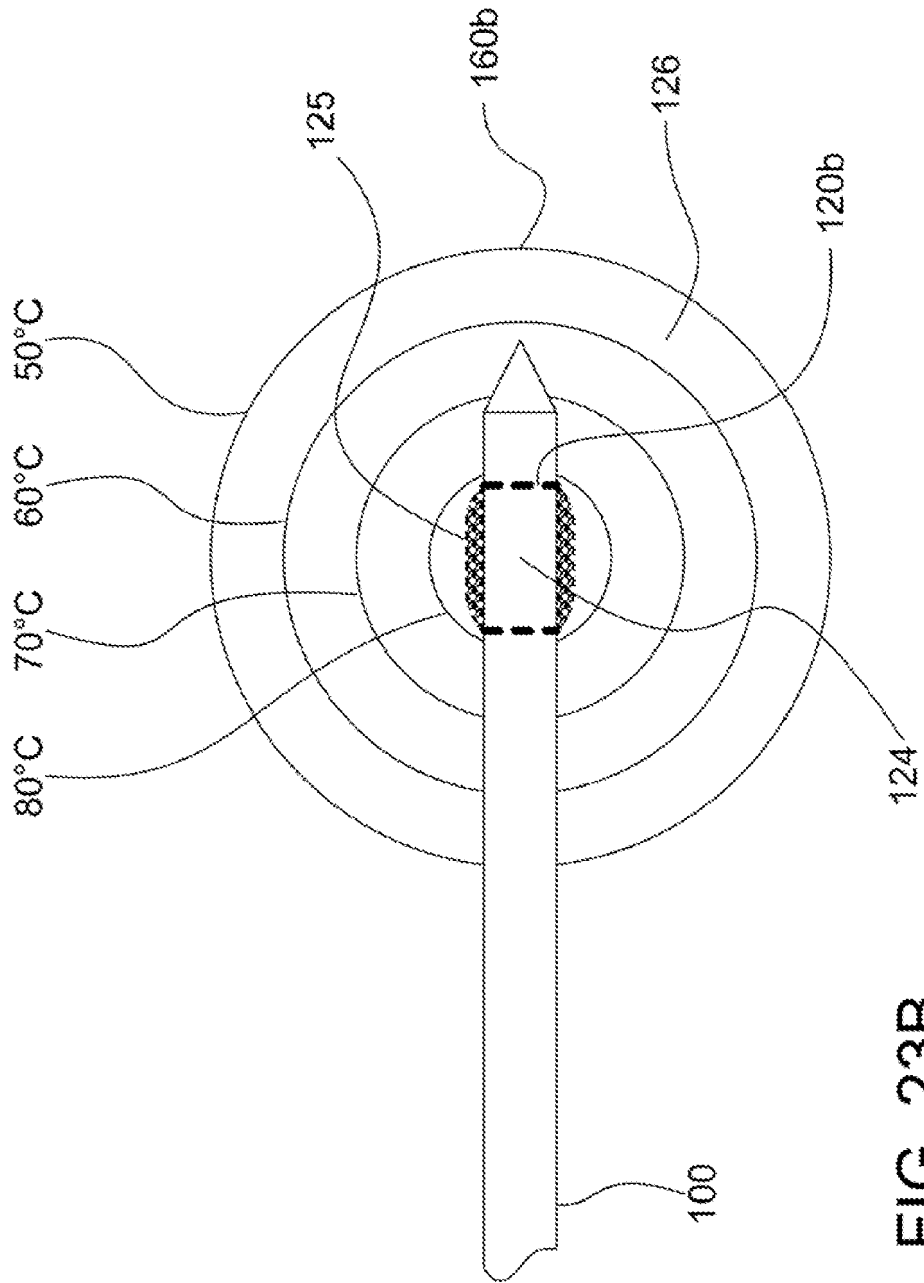

FIG. 23B

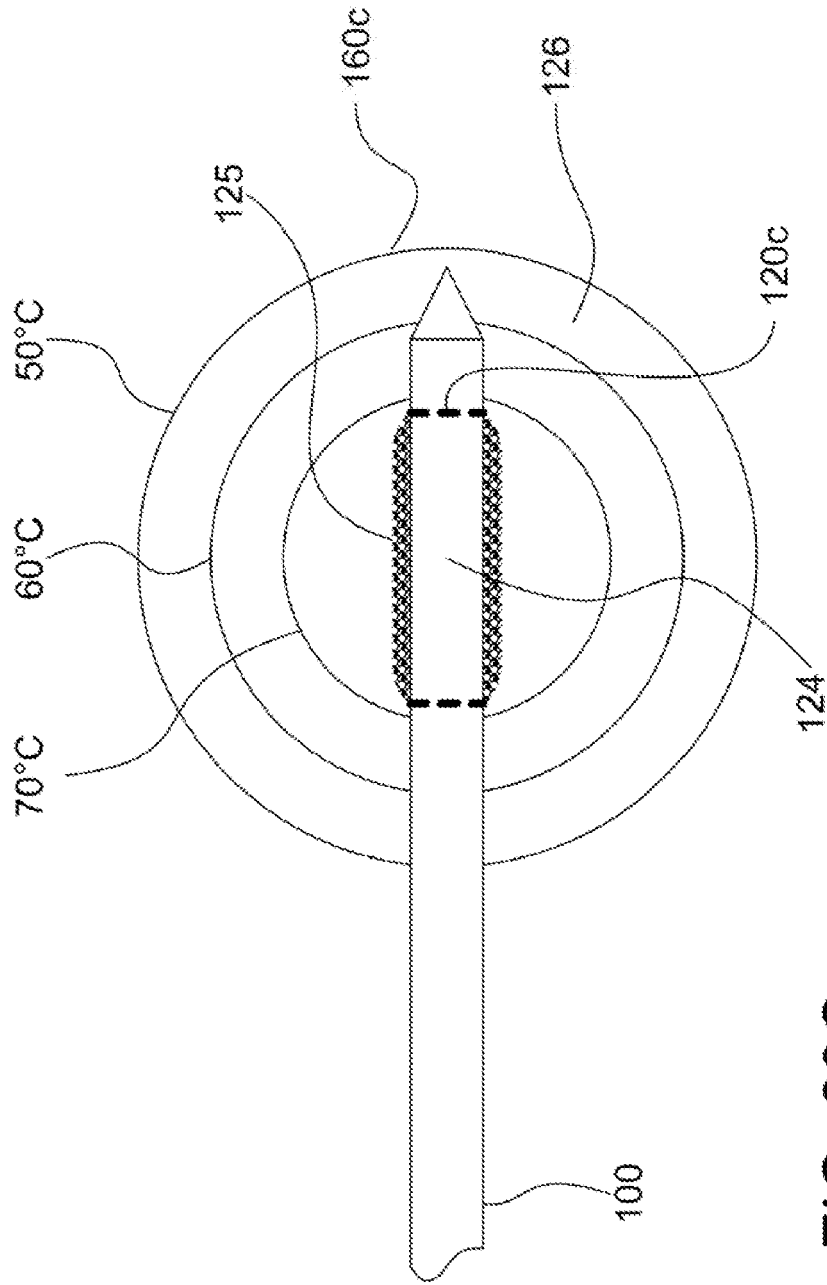

FIG. 23C

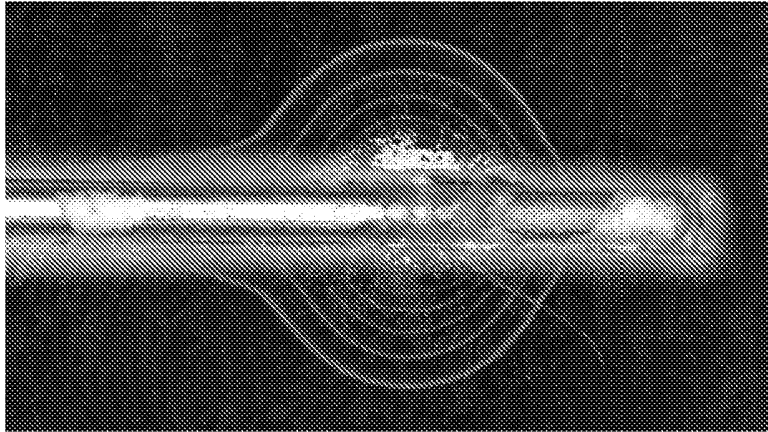

FIG. 24A

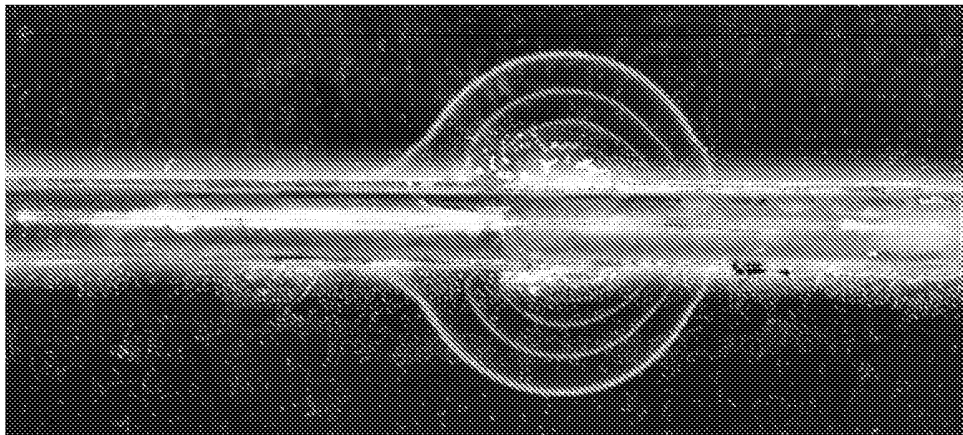

FIG. 24B

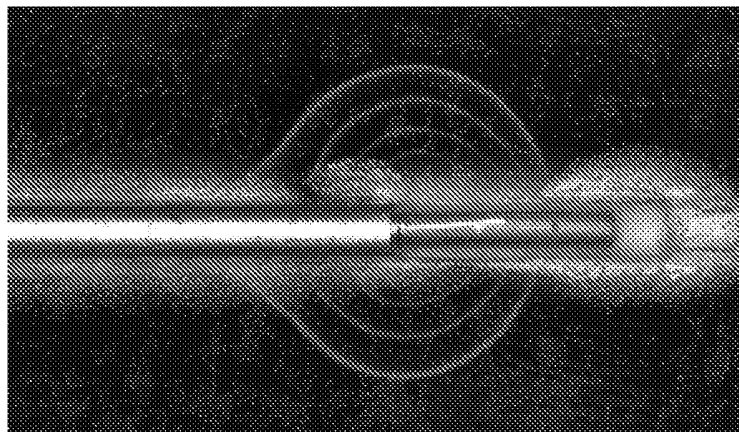

FIG. 24C

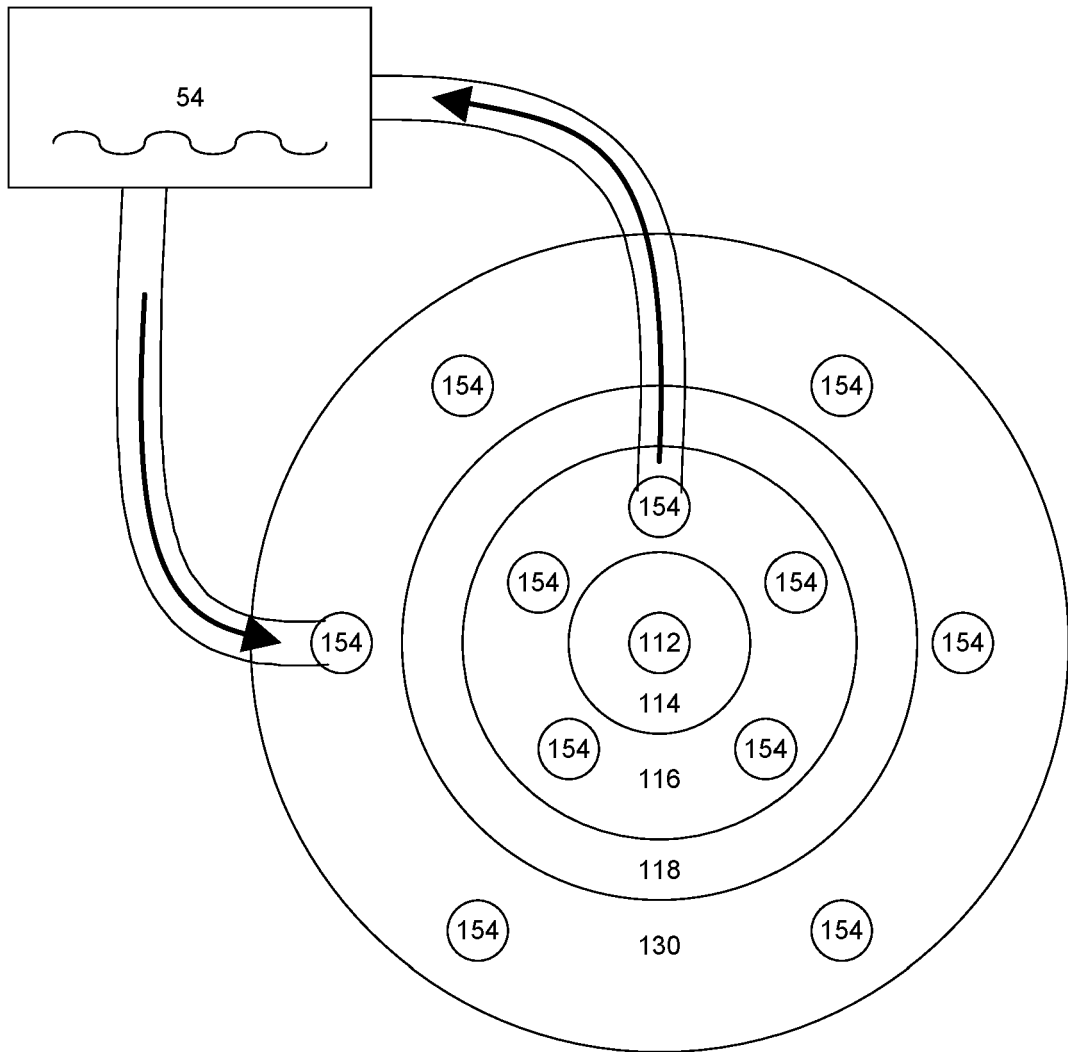

FIG. 25

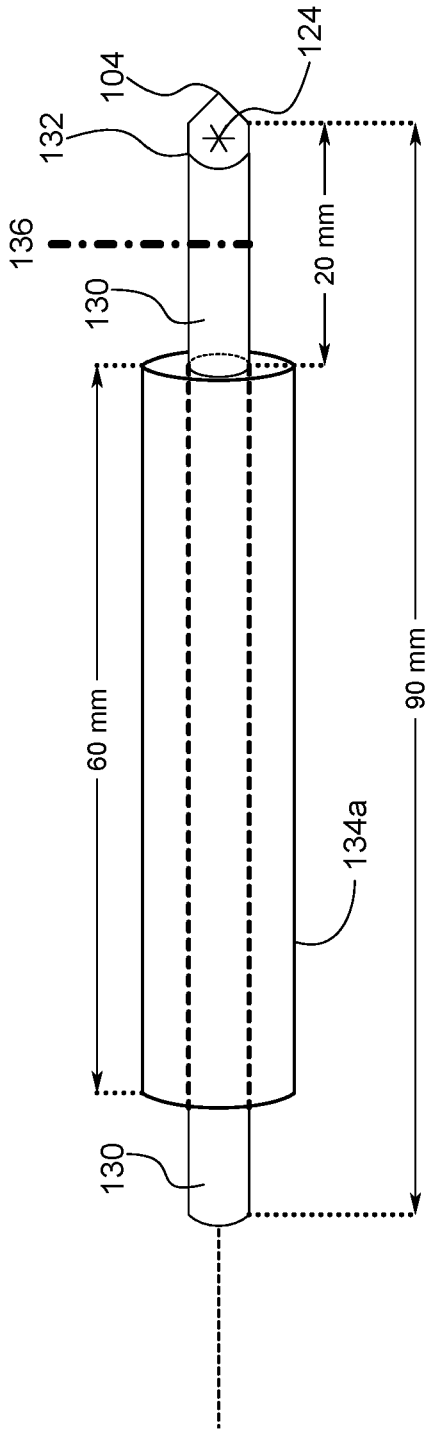

FIG. 26A

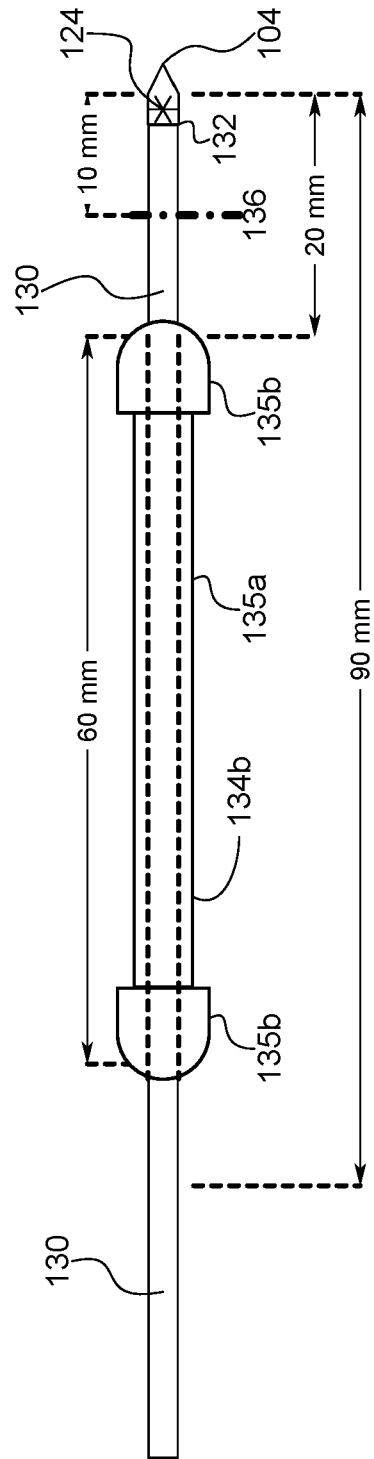

FIG. 26B

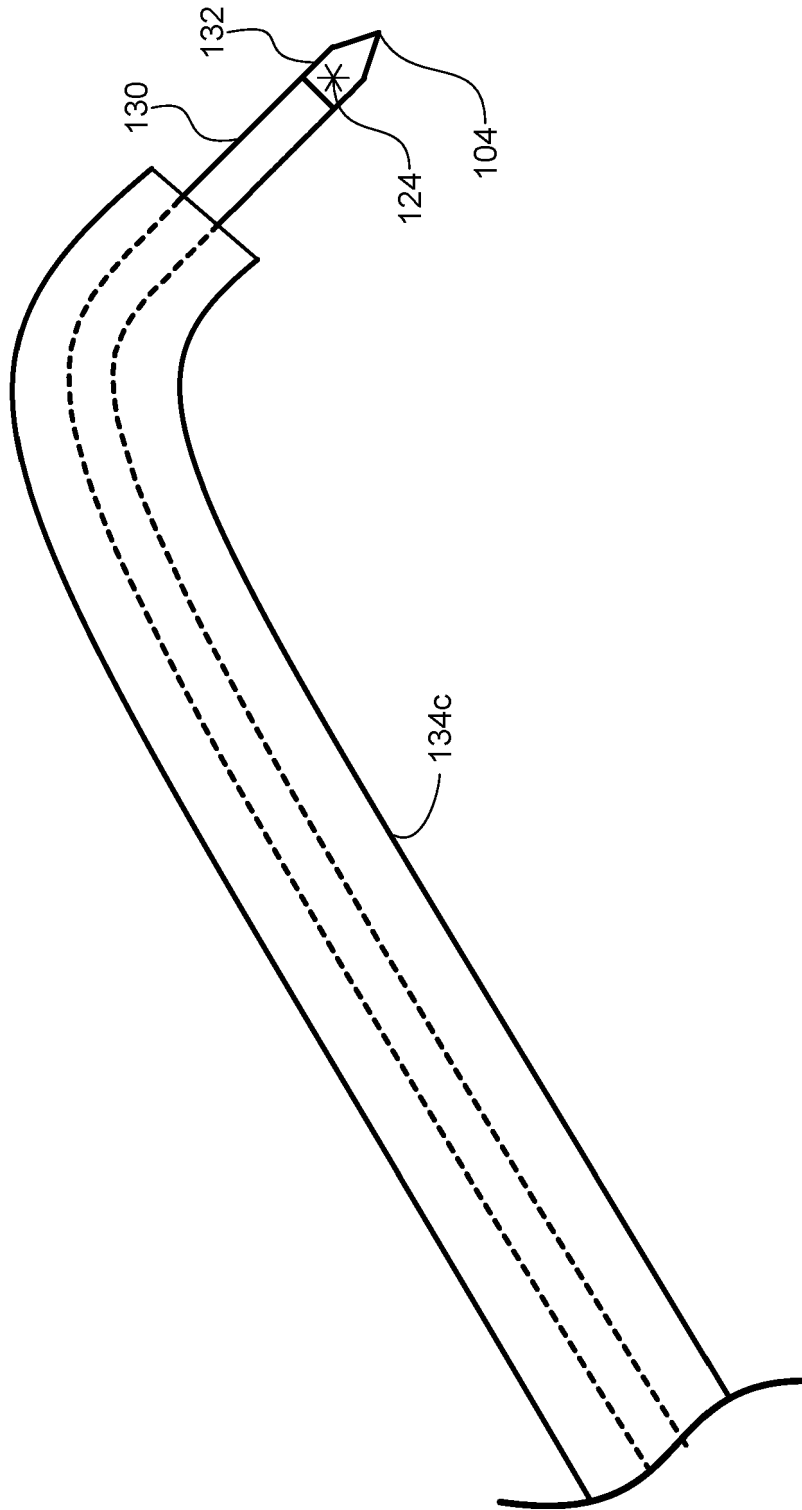

FIG. 26C

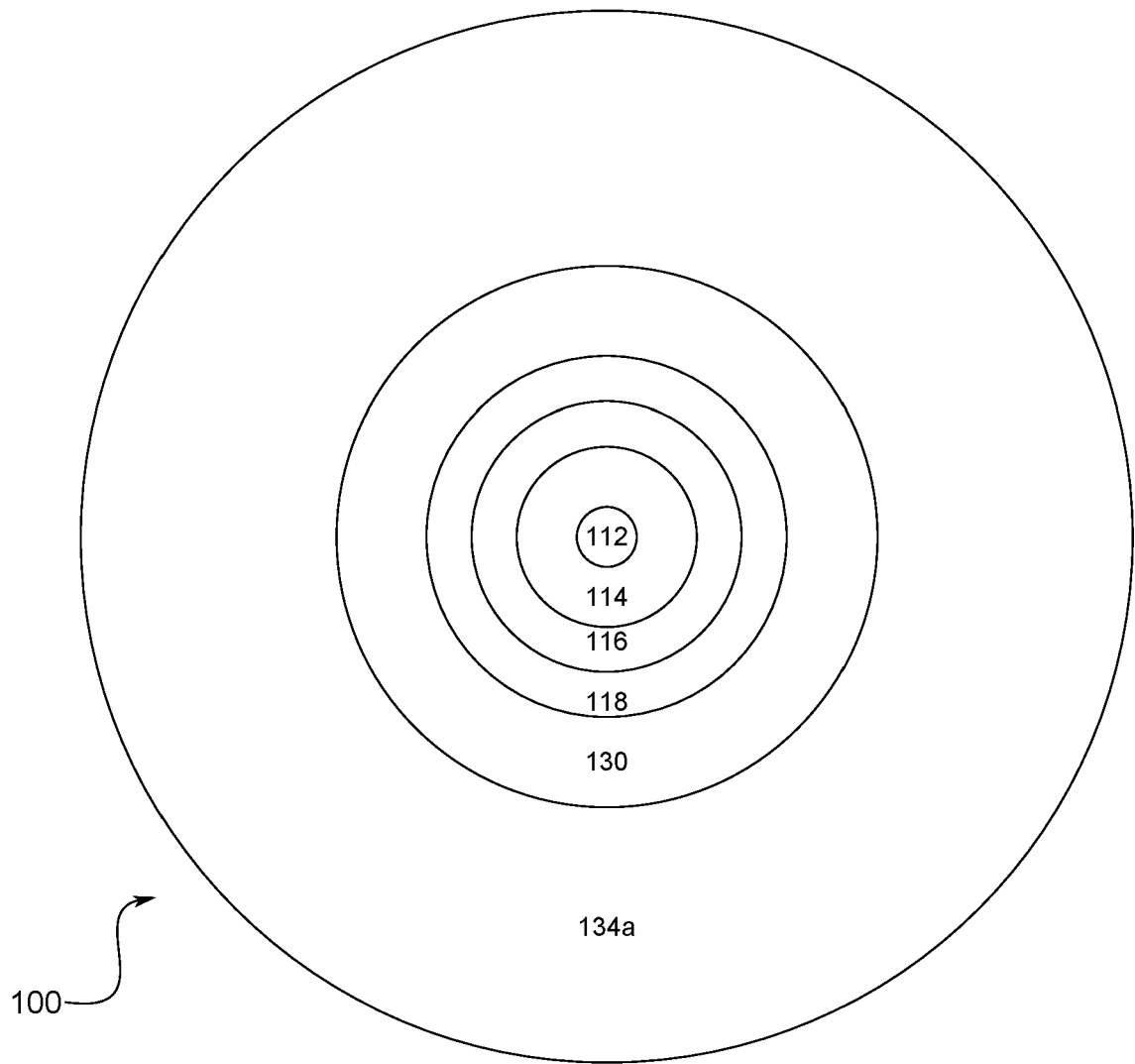

FIG. 26D

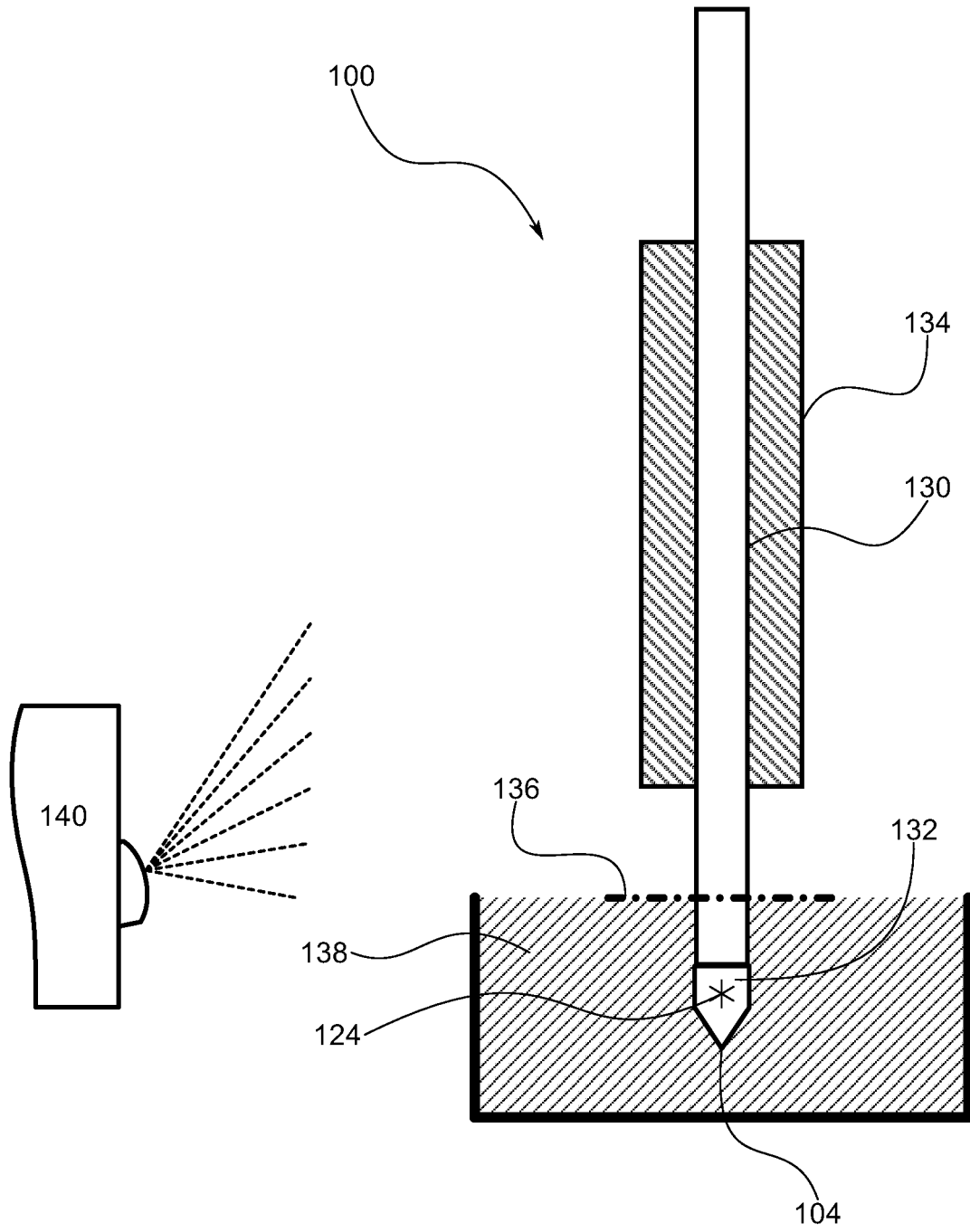

FIG. 27

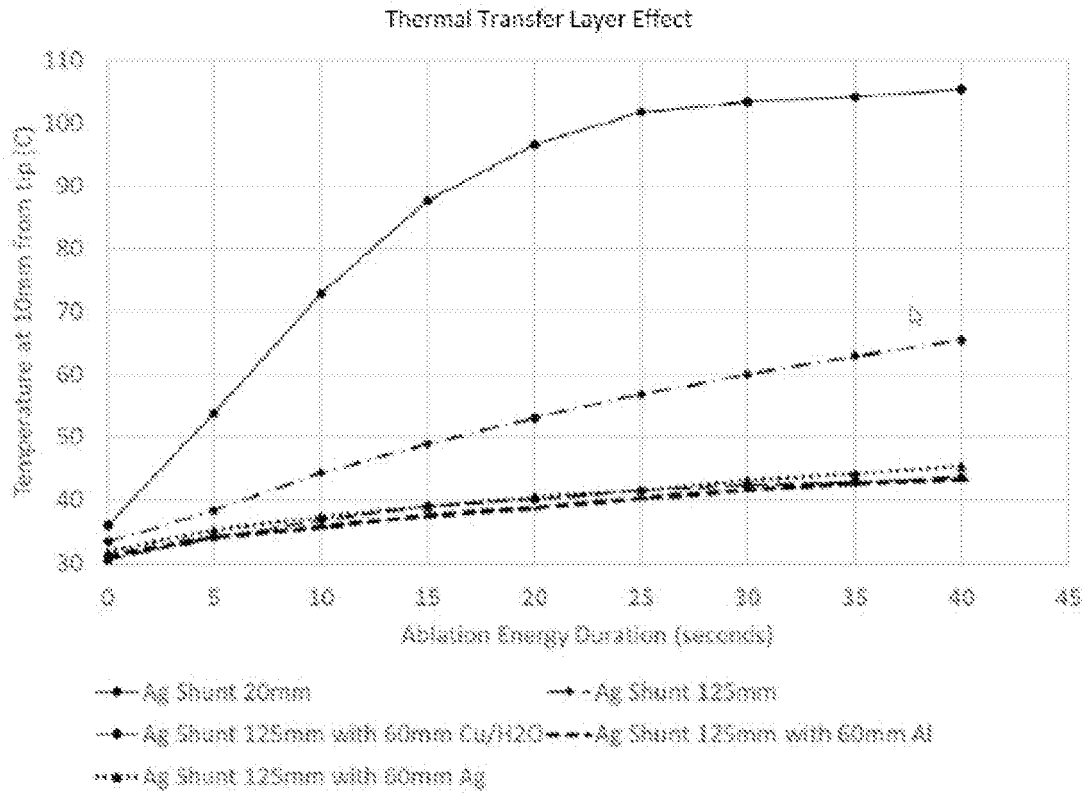

FIG. 28A

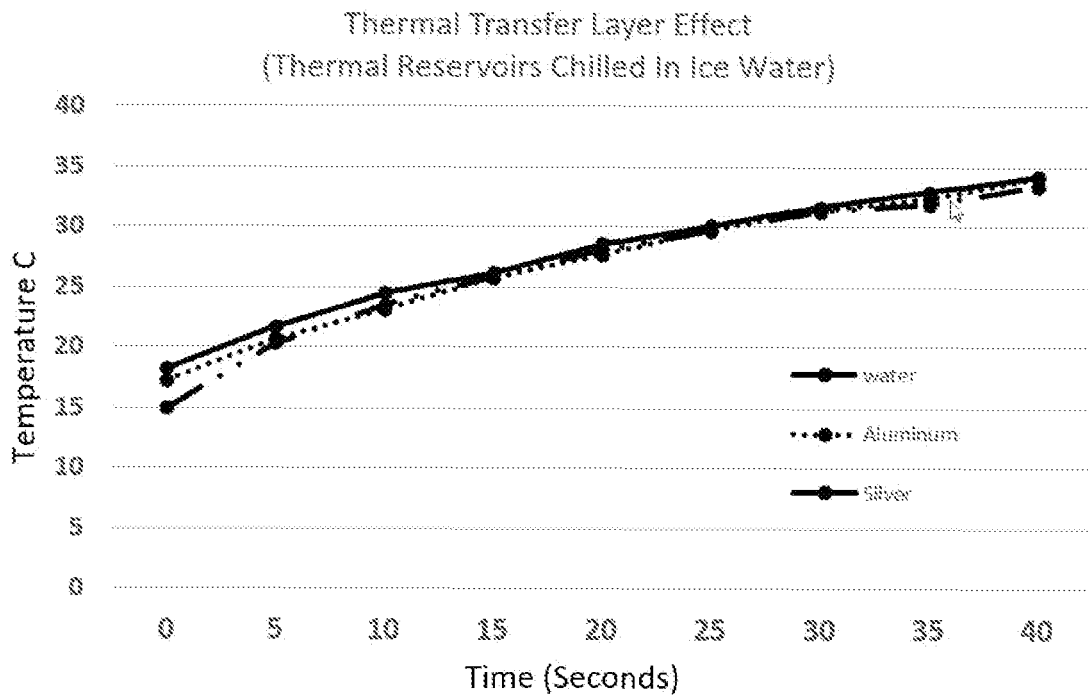

FIG. 28B

Probe Construction	Time (s)	Temp at 10.0 mm from tip (C)	Temp of Heatsink (C)	Start Temp (C)
Shunt 20.0 mm	0	36.0		23
Shunt 20.0 mm	5	53.8		23
Shunt 20.0 mm	10	72.9		23
Shunt 20.0 mm	15	87.6		23
Shunt 20.0 mm	20	96.7		23
Shunt 20.0 mm	25	101.8		23
Shunt 20.0 mm	30	103.4		23
Shunt 20.0 mm	35	104.2		23
Shunt 20.0 mm	40	105.5		23
Shunt 125.0 mm	0	33.5		23
Shunt 125.0 mm	5	38.4		23
Shunt 125.0 mm	10	44.3		23
Shunt 125.0 mm	15	48.9		23
Shunt 125.0 mm	20	53.0		23
Shunt 125.0 mm	25	56.7		23
Shunt 125.0 mm	30	60.0		23
Shunt 125.0 mm	35	62.9		23
Shunt 125.0 mm	40	65.5		23
Shunt 125.0 mm with 60.0 mm Cu/H2O	0	30.6	27.3	23
Shunt 125.0 mm with 60.0 mm Cu/H2O	5	34.1	27.2	23
Shunt 125.0 mm with 60.0 mm Cu/H2O	10	36.9	27.3	23
Shunt 125.0 mm with 60.0 mm Cu/H2O	15	39.0	28.1	23
Shunt 125.0 mm with 60.0 mm Cu/H2O	20	40.1	28.3	23
Shunt 125.0 mm with 60.0 mm Cu/H2O	25	41.4	28.9	23
Shunt 125.0 mm with 60.0 mm Cu/H2O	30	42.4	29.5	23
Shunt 125.0 mm with 60.0 mm Cu/H2O	35	42.8	29.7	23
Shunt 125.0 mm with 60.0 mm Cu/H2O	40	43.6	30.0	23
Shunt 125.0 mm with 60.0 mm Al	0	31.2	28.9	23
Shunt 125.0 mm with 60.0 mm Al	5	34.1	29.6	23
Shunt 125.0 mm with 60.0 mm Al	10	35.8	30.8	23
Shunt 125.0 mm with 60.0 mm Al	15	37.6	31.9	23
Shunt 125.0 mm with 60.0 mm Al	20	38.7	32.8	23

FIG. 29A

Probe Construction	Time (s)	Temp at 10.0 mm from tip (C)	Temp of Heatsink (C)	Start Temp (C)
Shunt 125.0 mm with 60.0 mm Al	25	40.2	34.1	23
Shunt 125.0 mm with 60.0 mm Al	30	41.5	35.4	23
Shunt 125.0 mm with 60.0 mm Al	35	42.7	36.5	23
Shunt 125.0 mm with 60.0 mm Al	40	43.2	37.0	23
Shunt 125.0 mm with 60.0 mm Ag	0	31.9	29.8	23
Shunt 125.0 mm with 60.0 mm Ag	5	35.4	25.8	23
Shunt 125.0 mm with 60.0 mm Ag	10	37.4	31.8	23
Shunt 125.0 mm with 60.0 mm Ag	15	38.9	33.0	23
Shunt 125.0 mm with 60.0 mm Ag	20	40.5	34.0	23
Shunt 125.0 mm with 60.0 mm Ag	25	41.5	35.0	23
Shunt 125.0 mm with 60.0 mm Ag	30	43.1	36.2	23
Shunt 125.0 mm with 60.0 mm Ag	35	44.2	37.2	23
Shunt 125.0 mm with 60.0 mm Ag	40	45.4	38.3	23
Shunt 20.0 mm	0			2
Shunt 20.0 mm	5			2
Shunt 20.0 mm	10			2
Shunt 20.0 mm	15			2
Shunt 20.0 mm	20			2
Shunt 20.0 mm	25			2
Shunt 20.0 mm	30			2
Shunt 20.0 mm	35			2
Shunt 20.0 mm	40			2
Shunt 125.0 mm	0			2
Shunt 125.0 mm	5			2
Shunt 125.0 mm	10			2
Shunt 125.0 mm	15			2
Shunt 125.0 mm	20			2
Shunt 125.0 mm	25			2
Shunt 125.0 mm	30			2
Shunt 125.0 mm	35			2
Shunt 125.0 mm	40			2

FIG. 29B

Probe Construction	Time (s)	Temp at 10.0 mm from tip (C)	Temp of Heatsink (C)	Start Temp (C)
Shunt 125.0 mm with 60.0 mm Cu/H2O	0	15.0	6.8	2
Shunt 125.0 mm with 60.0 mm Cu/H2O	5	20.3	7.3	2
Shunt 125.0 mm with 60.0 mm Cu/H2O	10	23.5	8.4	2
Shunt 125.0 mm with 60.0 mm Cu/H2O	15	25.9	9.5	2
Shunt 125.0 mm with 60.0 mm Cu/H2O	20	28.1	10.6	2
Shunt 125.0 mm with 60.0 mm Cu/H2O	25	29.7	11.4	2
Shunt 125.0 mm with 60.0 mm Cu/H2O	30	31.3	12.5	2
Shunt 125.0 mm with 60.0 mm Cu/H2O	35	31.9	13.7	2
Shunt 125.0 mm with 60.0 mm Cu/H2O	40	33.4	14.7	2
Shunt 125.0 mm with 60.0 mm Al	0	17.2	12.1	2
Shunt 125.0 mm with 60.0 mm Al	5	20.7	13.4	2
Shunt 125.0 mm with 60.0 mm Al	10	23.1	15.5	2
Shunt 125.0 mm with 60.0 mm Al	15	25.8	17.3	2
Shunt 125.0 mm with 60.0 mm Al	20	27.7	19.0	2
Shunt 125.0 mm with 60.0 mm Al	25	29.8	20.7	2
Shunt 125.0 mm with 60.0 mm Al	30	31.4	21.9	2
Shunt 125.0 mm with 60.0 mm Al	35	32.4	23.5	2
Shunt 125.0 mm with 60.0 mm Al	40	34.1	24.8	2
Shunt 125.0 mm with 60.0 mm Ag	0	18.2	14.1	2
Shunt 125.0 mm with 60.0 mm Ag	5	21.7	15.3	2
Shunt 125.0 mm with 60.0 mm Ag	10	24.5	17.1	2
Shunt 125.0 mm with 60.0 mm Ag	15	26.2	18.4	2
Shunt 125.0 mm with 60.0 mm Ag	20	28.6	20.4	2
Shunt 125.0 mm with 60.0 mm Ag	25	30.1	21.6	2
Shunt 125.0 mm with 60.0 mm Ag	30	31.7	22.7	2
Shunt 125.0 mm with 60.0 mm Ag	35	32.9	24.0	2
Shunt 125.0 mm with 60.0 mm Ag	40	34.2	25.2	2

FIG. 29C

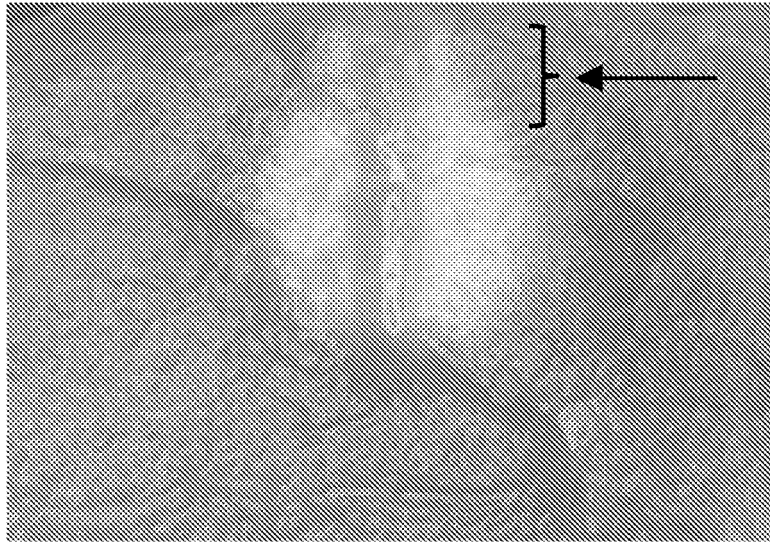

FIG. 30A

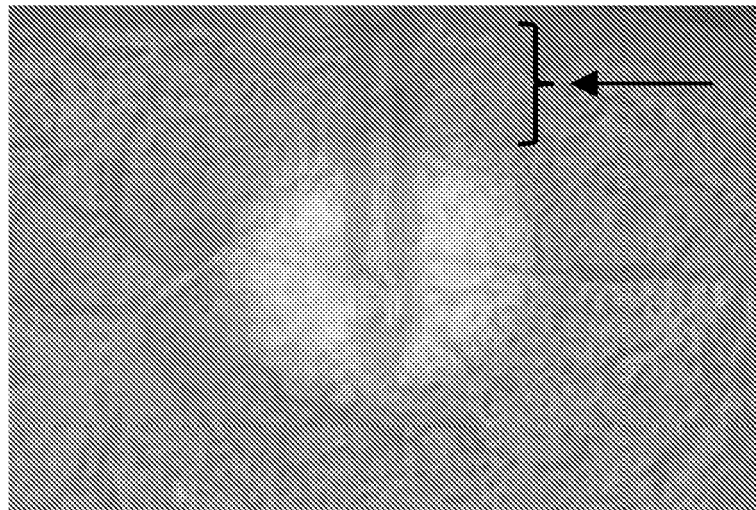

FIG. 30B

REFERENCES CITED IN THE DESCRIPTION

This list of references cited by the applicant is for the reader's convenience only. It does not form part of the European patent document. Even though great care has been taken in compiling the references, errors or omissions cannot be excluded and the EPO disclaims all liability in this regard.

Patent documents cited in the description

- US 9402693 B [0005]
- US 9827068 B [0005]
- US 9855112 B [0005]
- US 10022202 B [0005]
- US 10265140 B [0005]
- US 10285778 B [0005]
- US 10298255 B [0005]
- US 10299885 B [0005]
- US 20110200961 A [0005]
- US 20160324597 A [0005]
- US 20170360528 A [0005]
- US 20180091169 A [0005]
- US 20180153640 A [0005]
- US 20180318038 A [0005]
- WO 2010132368 A [0005]
- WO 2014143014 A [0005]
- US 7611508 B, Yang [0008] [0227]
- US 2011077635 A [0009]
- US 2020197089 A [0010]