



US010820963B2

(12) **United States Patent**
Colby

(10) **Patent No.:** **US 10,820,963 B2**

(45) **Date of Patent:** ***Nov. 3, 2020**

(54) **THERAPEUTIC TOOTH BUD ABLATION**

USPC 606/7-18, 32-52; 604/22; 433/72-76,
433/215, 224, 225

(75) Inventor: **Leigh E. Colby**, Eugene, OR (US)

See application file for complete search history.

(73) Assignee: **TRIAGENICS, INC.**, Eugene, OR (US)

(56) **References Cited**

(*) Notice: Subject to any disclaimer, the term of this patent is extended or adjusted under 35 U.S.C. 154(b) by 131 days.

U.S. PATENT DOCUMENTS

This patent is subject to a terminal disclaimer.

610,355 A 9/1898 Kinne et al.
752,378 A 2/1904 Dailey
1,713,971 A 5/1929 Lowry et al.

(Continued)

(21) Appl. No.: **13/093,844**

AU 2010247874 11/2010
AU 2015213338 9/2015

(22) Filed: **Apr. 26, 2011**

(Continued)

(65) **Prior Publication Data**

US 2011/0200961 A1 Aug. 18, 2011

FOREIGN PATENT DOCUMENTS

Related U.S. Application Data

(63) Continuation of application No. 12/863,183, filed as application No. PCT/US2010/034259 on May 10, 2010, now Pat. No. 9,402,693.

OTHER PUBLICATIONS

Silvestrini et al "Selectively Preventing Development of Third Molars in Rats Using Electrosurgical Energy"; J Am Dent Assoc; vol. 135, No. 10; Oct. 2004; pp. 1397-1405.*

(Continued)

(60) Provisional application No. 61/177,143, filed on May 11, 2009.

Primary Examiner — Jon Eric C Morales

(74) *Attorney, Agent, or Firm* — Green, Howard & Mughal, LLP; Karen Dana Oster

(51) **Int. Cl.**

A61C 13/28 (2006.01)
A61C 1/08 (2006.01)
A61C 3/00 (2006.01)
A61C 5/42 (2017.01)

(57) **ABSTRACT**

An ablation procedure. The ablation procedure may be applied to tooth buds **120** and result in tooth agenesis. The ablation procedure may be applied to lesions or tumors. A tooth bud ablation system for use in a tooth bud ablation procedure that results in tooth agenesis. A method for volume scanning both hard tissues and soft tissues of a patient. A method for manufacturing or fabricating a custom surgical stent **110**. A custom surgical stent **110** for use in a tooth bud ablation procedure that results in tooth agenesis, the custom surgical stent **110** for use with an ablation probe tip **108** having a center of ablation **130a**.

(52) **U.S. Cl.**

CPC **A61C 1/082** (2013.01); **A61C 3/00** (2013.01); **A61C 5/42** (2017.02); **Y10T 29/49826** (2015.01)

(58) **Field of Classification Search**

CPC A61C 1/082; A61C 3/00; A61C 5/023; A61C 8/0001; A61C 8/0089; A61C 8/009; A61C 9/004-0093; A61C 13/0004-0024

27 Claims, 29 Drawing Sheets

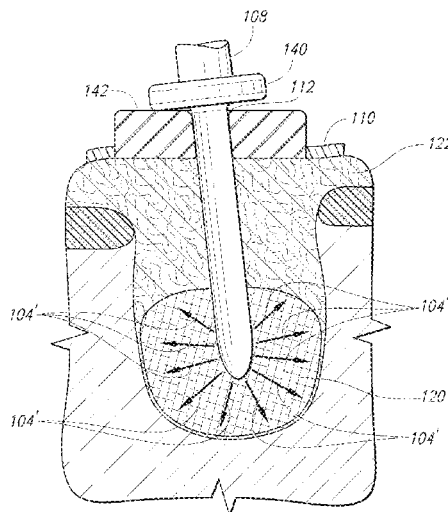

(56)

References Cited

U.S. PATENT DOCUMENTS

2,317,648	A	4/1943	Siqveland		8,626,317	B2	1/2014	Higgins	
4,672,963	A	6/1987	Barken		8,670,816	B2	3/2014	Green et al.	
4,895,517	A	1/1990	Fischer		8,834,409	B2	9/2014	Manley	
4,925,523	A	5/1990	Braren et al.		8,892,235	B2	11/2014	Choi et al.	
5,009,595	A	4/1991	Osborn		8,945,144	B2	2/2015	Cunningham	
5,015,183	A	5/1991	Fenick		8,979,871	B2	3/2015	Tyc et al.	
5,133,660	A	7/1992	Fenick		9,028,252	B1	5/2015	Shabat	
5,500,012	A	3/1996	Brucker et al.		9,066,712	B2	6/2015	Fourkas et al.	
5,556,278	A	9/1996	Meitner		9,113,912	B1	8/2015	Mehta et al.	
5,613,852	A	3/1997	Bavitz		9,119,628	B1	9/2015	Mehta et al.	
5,623,931	A	4/1997	Wung et al.		9,168,091	B2	10/2015	Janssen et al.	
5,642,997	A	7/1997	Gregg, II et al.		9,271,796	B2	3/2016	Buysse et al.	
5,688,118	A	11/1997	Hayka et al.		9,402,691	B2	8/2016	Merritt et al.	
5,725,376	A *	3/1998	Poirier	A61C 1/084 433/172	9,402,693	B2 *	8/2016	Colby	A61C 5/42
					9,415,194	B2	8/2016	Wolf et al.	
					9,622,813	B2	4/2017	Krugman et al.	
					9,724,236	B2	8/2017	Abe	
					9,827,068	B2	11/2017	Colby	
					9,844,324	B2	12/2017	Merritt et al.	
5,768,134	A	6/1998	Swaelens et al.		9,855,112	B2	1/2018	Colby	
5,792,140	A	8/1998	Tu et al.		9,943,374	B2	4/2018	Merritt et al.	
5,800,168	A	9/1998	Cascione et al.		10,022,202	B2	7/2018	Colby	
5,816,814	A	10/1998	Venta et al.		10,265,140	B2	4/2019	Colby	
5,843,021	A	12/1998	Edwards et al.		10,285,778	B2	5/2019	Colby	
5,851,112	A	12/1998	Daikuzono et al.		10,298,255	B2	5/2019	Colby	
5,906,609	A *	5/1999	Assa	A61B 18/203 606/11	10,299,885	B2	5/2019	Colby	
					10,350,008	B2	7/2019	Gibbs et al.	
5,916,213	A	6/1999	Haissaguerre		2002/0058872	A1	5/2002	Steininger et al.	
5,941,845	A	8/1999	Tu et al.		2002/0128642	A1	9/2002	Berube et al.	
5,941,889	A	8/1999	Cermak		2002/0160337	A1	10/2002	Klein et al.	
5,943,719	A	8/1999	Feldman et al.		2003/0130575	A1	7/2003	Desai	
5,967,777	A	10/1999	Klein et al.		2004/0102767	A1	5/2004	Stingl et al.	
6,027,497	A *	2/2000	Daniel et al.	606/15	2004/0157188	A1	8/2004	Luth et al.	
6,162,052	A	12/2000	Kokubu		2004/0158194	A1	8/2004	Wolf et al.	
6,179,803	B1	1/2001	Edwards et al.		2004/0215186	A1	10/2004	Cornelius et al.	
6,179,830	B1 *	1/2001	Kokubu	606/16	2004/0219482	A1	11/2004	Bina et al.	
6,203,499	B1	3/2001	Imling et al.		2004/0249370	A1	12/2004	Berna et al.	
6,210,355	B1 *	4/2001	Edwards et al.	604/22	2005/0090820	A1	4/2005	Cornelius et al.	
6,241,725	B1	6/2001	Cosman		2005/0170312	A1	8/2005	Pond	
6,245,062	B1	6/2001	Berube et al.		2005/0177074	A1	8/2005	Becker et al.	
6,270,476	B1	8/2001	Santojanni et al.		2005/0186533	A1	8/2005	Cohen	
6,319,006	B1 *	11/2001	Scherer et al.	433/75	2005/0283148	A1	12/2005	Janssen et al.	
6,386,869	B1	5/2002	Zegarelli		2006/0009404	A1	1/2006	Williams	
6,607,524	B1	8/2003	LaBudde et al.		2006/0074413	A1	4/2006	Behzadian	
6,621,491	B1	9/2003	Baumrind et al.		2006/0084958	A1	4/2006	Raif et al.	
6,622,731	B2	9/2003	Daniel et al.		2006/0111705	A1	5/2006	Janzen et al.	
6,913,463	B2	7/2005	Blacklock		2006/0115782	A1	6/2006	Li et al.	
6,936,046	B2	8/2005	Hissong et al.		2006/0127859	A1	6/2006	Wen	
6,971,877	B2	12/2005	Harter		2006/0195169	A1	8/2006	Gross et al.	
7,014,461	B2	3/2006	Weinstein		2006/0240378	A1 *	10/2006	Weinstein	A61B 5/103 433/76
7,044,735	B2	5/2006	Malin						
7,097,451	B2	8/2006	Tang		2007/0016183	A1	1/2007	Lee et al.	
7,169,155	B2	1/2007	Chu et al.		2007/0135707	A1	6/2007	Redel et al.	
7,226,288	B2	6/2007	Schoeffel		2007/0179485	A1	8/2007	Yeik et al.	
7,249,952	B2	7/2007	Ranta et al.		2007/0224570	A1	11/2007	West et al.	
7,346,417	B2	3/2008	Luth et al.		2007/0265628	A1	11/2007	Kraus et al.	
7,457,443	B2	11/2008	Persky		2007/0293756	A1	12/2007	Jung et al.	
7,492,987	B2	1/2009	Yeik et al.		2007/0294280	A1	12/2007	Jung et al.	
7,553,309	B2	6/2009	Buysse et al.		2008/0009747	A1	1/2008	Saadat et al.	
7,615,047	B2 *	11/2009	Berna	A61B 17/16 433/29	2008/0039709	A1	2/2008	Karmarkar	
					2008/0138761	A1	6/2008	Pond	
					2008/0176187	A1	7/2008	Stumpel	
7,776,035	B2	8/2010	Rick et al.		2008/0182218	A1	7/2008	Chen et al.	
7,787,132	B2	8/2010	Korner et al.		2008/0199829	A1	8/2008	Paley et al.	
7,812,815	B2	10/2010	Banerjee et al.		2009/0011382	A1	1/2009	Bavar	
7,819,591	B2	10/2010	Rohaly et al.		2009/0062790	A1	3/2009	Malchano et al.	
7,959,441	B2	6/2011	Glover et al.		2009/0076498	A1	3/2009	Saadat et al.	
7,976,469	B2	7/2011	Bonde et al.		2009/0088830	A1	4/2009	Mohamed et al.	
7,990,548	B2	8/2011	Babayoff et al.		2009/0136902	A1	5/2009	Zundorf et al.	
8,013,853	B1	9/2011	Douglas et al.		2009/0253095	A1	10/2009	Salcedo et al.	
8,048,067	B2 *	11/2011	Davalos et al.	606/32	2009/0258330	A1	10/2009	Huber et al.	
8,057,487	B2	11/2011	Chu et al.		2009/0263764	A1	10/2009	Berckmans, III et al.	
8,211,099	B2	7/2012	Buysse et al.		2009/0306652	A1	12/2009	Buysse et al.	
8,221,121	B2	7/2012	Berckmans, III et al.		2010/0021866	A1	1/2010	Tsuji et al.	
8,257,341	B1	9/2012	Fletcher		2010/0035201	A1	2/2010	Beck et al.	
8,310,683	B2	11/2012	Babayoff et al.		2010/0082032	A1	4/2010	Berna et al.	
8,363,228	B2	1/2013	Babayoff		2010/0100094	A1	4/2010	Truckai	
8,372,061	B2	2/2013	Berna et al.		2010/0114184	A1	5/2010	Degtyar et al.	
8,377,057	B2	2/2013	Rick et al.		2010/0129771	A1	5/2010	Tsuji et al.	
8,480,666	B2	7/2013	Buysse et al.						

(56) **References Cited**

U.S. PATENT DOCUMENTS

2010/0203479	A1	8/2010	Bulloch
2010/0311006	A1	12/2010	Lancieux et al.
2010/0311028	A1	12/2010	Bell, III et al.
2010/0316974	A1	12/2010	Yau et al.
2011/0104632	A1	5/2011	Colby
2011/0130689	A1	6/2011	Cohen et al.
2011/0137156	A1	6/2011	Razzaque et al.
2011/0200960	A1	8/2011	Colby
2011/0200961	A1	8/2011	Colby
2011/0244417	A1	10/2011	Hilsen et al.
2012/0046536	A1	2/2012	Cheung et al.
2012/0100500	A1	4/2012	Gao
2013/0017507	A1	1/2013	Moffson et al.
2013/0150843	A1	6/2013	Berna et al.
2013/0172731	A1	7/2013	Gole
2013/0197355	A1	8/2013	Lee et al.
2014/0066917	A1	3/2014	Cosman, Jr. et al.
2014/0081260	A1	3/2014	Cosman, Jr. et al.
2014/0093838	A1	4/2014	Carmichael et al.
2014/0121658	A1	5/2014	Cosman, Jr. et al.
2014/0186796	A1	7/2014	Suttin
2014/0193771	A1	7/2014	Dolfi et al.
2014/0257272	A1	9/2014	Clark, III et al.
2014/0276033	A1	9/2014	Brannan et al.
2014/0378964	A1	12/2014	Pearson
2015/0018801	A1	1/2015	Lazarof
2015/0018822	A1	1/2015	Racz
2015/0147714	A1	5/2015	Daon
2015/0150631	A1	6/2015	Lee
2015/0265371	A1	9/2015	Kim
2015/0351831	A1	12/2015	Janssen et al.
2015/0374456	A1	12/2015	Colby
2015/0374457	A1	12/2015	Colby
2016/0106518	A1	4/2016	Choi et al.
2016/0157967	A1	6/2016	Kim et al.
2016/0324597	A1	11/2016	Colby
2017/0039489	A1	2/2017	Reh et al.
2017/0231718	A1	8/2017	Wohrle
2017/0290554	A1	10/2017	Merritt
2017/0360528	A1	12/2017	Colby
2018/0014910	A1	1/2018	Colby
2018/0091169	A1	3/2018	Colby
2018/0153640	A1	6/2018	Colby
2018/0318038	A1	11/2018	Colby

FOREIGN PATENT DOCUMENTS

EP	2429444	3/2012	
FR	2925289	1/2011	
GB	2057888	* 4/1981	433/75
MX	357449	7/2018	
WO	WO2006031317	6/2006	
WO	WO 2007/057902	A3 5/2007	
WO	WO2007057902	5/2007	
WO	WO 2007/085719	8/2007	
WO	WO 2008/067334	A3 6/2008	
WO	WO2008067334	6/2008	
WO	WO2008/128720	10/2008	
WO	WO2010132368	11/2010	

OTHER PUBLICATIONS

Silvestrini et al.; "Prevention of Third Molar Development in Dog With Long Pulse Diode Laser: A Preliminary Report"; *Lasers Surg Med* vol. 39, No. 8; Sep. 2007; pp. 674-677.*
 Kiukkonen Toxicity of dioxin to developing teeth and salivary glands Helsinki University Biomedical Dissertations No. 77 06-2006.*
 Gordon et al The Effects of Local Hypothermia on Odontogenesis *J Oral Surg* vol. 37, Apr. 1979, pp. 235-244.*
 Patent Cooperation Treaty, International Search Report, dated Sep. 14, 2010.
 Patent Cooperation Treaty, International Preliminary Report on Patentability, dated Aug. 31, 2011.

Silvestri et al.; "Selectively preventing development of third molars in rats using electrosurgical energy;" © 2004 American Dental Association, all rights reserved; *JADA*, vol. 135, Oct. 2004, pp. 1397-1405.
 Patent Cooperation Treaty, International Searching Authority, International Search Report and Written Opinion of PCT/US13/32357, dated Jun. 5, 2013, 24 pages.
 Australian Government, IP Australia, Patent Examination Report No. 1 (2010247874), dated Jan. 2, 2014, 3 pages.
 Ahmad et al., Abstract of "Caries Experience and Periodontal Pathology in Erupting Third Molars," *Journal of Oral and Maxillofacial Surgery*, 2008; 66(5):948-53 (ISSN: 1531-5053), Chapel Hill, NC 27599, USA, 1 page.
 Al-Khateeb et al., Abstract of "Pathology Associated with Impacted Mandibular Third Molars in a Group of Jordanians," *Journal of Oral and Maxillofacial Surgery*, 2006, 64(11):1598-602, Irbid, Jordan, 1 page.
 Bataineh, A.B., Abstract of "Sensory Nerve Impairment Following Mandibular Third Molar Surgery," *Journal of Oral and Maxillofacial Surgery*, 2001, 59(9):1012-7 (ISSN: 0278-2391), Irbid, Jordan, 1 page.
 Blakey et al., Abstract of "Impact of Removal of Asymptomatic Third Molars on Periodontal Pathology," *Journal of Oral and Maxillofacial Surgery*, 2009, 67(2): 245-50. Chapel Hill, NC 27599, USA, 2 pages.
 Blakey et al., Abstract of "Periodontal Pathology Associated with Asymptomatic Third Molars," *Journal of Oral and Maxillofacial Surgery*, 2002, 60(11):1227-33 (ISSN: 0278-2391). Chapel Hill, NC 27599, USA, 1 page.
 Blondeau et al., Abstract of "Extraction of Impacted Mandibular Third Molars: Postoperative Complications and Their Risk Factors," *Journal of the Canadian Dental Association*, Jun. 2007, vol. 73, No. 4, (ISSN: 1488-2159), 2 pages.
 Christiaens et al. Abstract of "Complications After Third Molar Extractions: Retrospective Analysis of 1,213 Teeth," *Rev Stomatol Chir Maxillofac*, 2002, 103(5):269-74 (ISSN: 0035-1768), Belgique, France, 2 pages.
 Elter et al., Abstract of "Third Molars Associated with Periodontal Pathology in the Third National Health and Nutrition Examination Survey," *Journal of Oral and Maxillofacial Surgery*, 2004, 62(4):440-5, Chapel Hill, NC 27599, USA, 1 page.
 Elter et al., Abstract of "Third Molars Associated with Periodontal Pathology in Older Americans," *Journal of Oral and Maxillofacial Surgery*, Feb. 2005, 63(2):179-84, Chapel Hill, NC 27599, USA, 1 page.
 Friedman, J.W., "The Prophylactic Extraction of Third Molars: A Public Health Hazard," *American Journal of Public Health*, vol. 97, No. 9, Sep. 2007, Los Angeles, CA 90064, USA, pp. 1554-1559.
 Hicks, E.P., Abstract of "Third Molar Management: A Case Against Routine Removal in Adolescent and Young Adult Orthodontic Patients," *Journal of Oral and Maxillofacial Surgery*, 1999, 57(7):831-6, Lexington, KY, USA, 2 pages.
 Jiang, P., "Ten-Year Insurance Claims Data Study Reveals Increase in Utilization of Surgical Extraction Codes," *Online Periodical*, Winter 2006/2007, Delta Dental of Minnesota, Eagan, MN 55122, USA, 2 pages.
 Kajii et al., Abstract of "Presence of Third Molar Germs in Orthodontic Patients in Japan," *American Journal of Orthodontics & Dentofacial Orthopedics*, vol. 119, Issue 3, pp. 245-250, Mar. 2001, 2 pages.
 Kaminishi et al., Abstract of "A 10-year Comparative Study of the Incidence of Third Molar Removal in the Aging Population," *Journal of Oral Maxillofacial Surgery*, 2006, 64(2):173-4 (ISSN: 0278-2391), Los Angeles, CA, USA, 1 page.
 Kaminishi et al., Abstract of "New Considerations in the Treatment of Compromised Third Molars," *Journal of the California Dental Association*, 2004, 32(10):823-5 (ISSN: 1043-2256), Los Angeles, CA, 1 page.
 Kan et al., Abstract of "Residual Periodontal Defects Distal to the Mandibular Second Molar 6-36 Months after Impacted Third Molar Extraction," *J. Clinical Periodontal*, Nov. 2002, 29(11):1004-11, Hong Kong SAR, China, 1 page.

(56)

References Cited

OTHER PUBLICATIONS

- Knutsson et al., Abstract of "Dentists' Decisions on Prophylactic Removal of Mandibular Third Molars: A 10-year Follow-up Study," *Community Dental and Oral Epidemiology*, 2001, 29(4):308-14, Malmö University, Sweden, 1 page.
- Kunkel et al., Abstract of "Severe Third Molar Complications Including Death—Lessons from 100 Cases Requiring Hospitalization," *Journal of Oral Maxillofacial Surgery*, 2007, 65(9):1700-6, Mainz, Germany, 1 page.
- Kunkel et al., Abstract of "Third Molar Complications Requiring Hospitalization," *Oral Surg. Oral Med. Oral Pathol. Oral Radiol. Endod.*, 2006, 102(3):300-6 (ISSN: 1528-395X), Mainz, Germany, 1 page.
- Langsten et al., Abstract of "The Impact of Retained Third Molars on the Deployed Airman," *Military Medicine*, vol. 173, Supplement 1, Jan. 2008, pp. 27-28(2), Publisher: AMSUS, Eglin Air Force Base, FL 32542, 1 page.
- McArdle et al., Abstract of "Distal Cervical Caries in the Mandibular Second Molar: An Indication for the Prophylactic Removal of the Third Molar?" *British Journal of Oral Maxillofacial Surgery*, Feb. 2006, 44(1):42-5, London, UK, 1 page.
- Moss et al., Abstract of "Third Molar Periodontal Pathology and Caries in Senior Adults," *Journal of Oral Maxillofacial Surgery*, 2007, 65(1):103-8 (ISSN: 0278-2391), Chapel Hill, NC 27599, USA, 2 page.
- Nance et al., Abstract of "Change in Third Molar Angulation and Position in Young Adults and Follow-up Periodontal Pathology," *Journal Oral Maxillofacial Surgery*, Mar. 2006, 64(3):424-8. Chapel Hill, NC 27599, USA, 1 page.
- Rakprasitkul, S., Abstract of "Pathologic Changes in the Pericoronal Tissues of Unerupted Third Molars," *Quintessence International*, 2001, 32(8):633-8 (ISSN: 0033-6572), Rajithevee, Bangkok, Thailand 10400, 1 page.
- Sarnat et al., Abstract of "Developmental Stages of the Third Molar in Israeli Children," *Pediatric Dentistry*, 2003, 25 (4):373-7 (ISSN: 0164-1263), Tel Aviv, Israel, 1 page.
- Shugars et al., Abstract of "Incidence of Occlusal Dental Caries in Asymptomatic Third Molars," *Journal Oral Maxillofacial Surgery*, 2005, 63(3):341-6 (ISSN: 0278-2391), Chapel Hill, NC 27599, USA, 1 page.
- Silvestri et al., Abstract of "Prevention of Third Molar Development in Dog with Long Pulse Diode Laser: A Preliminary Report," *Lasers Surg. Med.*, 2007, 39(8):674-7 (ISSN: 0196-8092), Boston, MA 02111, USA, 1 page.
- Silvestri et al., Abstract of "Prevention of Third Molar Tooth Development in Neonate Rat with a Long Pulse Diode Laser," *Lasers Surg. Med.*, 2004, 35(5):385-91 (ISSN: 0196-8092), Boston, MA 02111, USA, 1 page.
- Song et al., "Executive Summary: The Effectiveness and Cost-Effectiveness of Prophylactic Removal of Wisdom Teeth," *Executive Summary, Health Technology Assessment*, 2000, vol. 4: No. 15, 4 pages.
- Venta et al., Abstract of "Change in Clinical Status of Third Molars in Adults during 12 Years of Observation," *Journal Oral Maxillofacial Surgery*, 1999, 57(4):386-9 (ISSN: 0278-2391), Helsinki, Finland, 1 page.
- Venta et al., Abstract of "Malpractice Claims for Permanent Nerve Injuries Related to Third Molar Removals," *Acta. Odontol. Scand.*, 1998, 56(4):193-6 (ISSN: 0001-6357), Helsinki, Finland, 1 page.
- Voegelin et al., Abstract of "Complications during and after Surgical Removal of Mandibular Third Molars. Impact of Patient Related and Anatomical Factors," *Schweiz Monatsschr Zahnmed*, 2008, 118(3):192-8, Bern, Switzerland, 2 pages.
- Fox, M.; "Shots kill budding wisdom teeth, study suggests," © NBCNews.com; Apr. 2013; http://vitals.nbcnews.com/_news/2013/04/03/17584797-shots-kill-budding-wisdom-teeth-study-suggests%0D%0A%0D%0ANBCNews.com; New York, NY.
- Harrison, L.; "Nerve blocks in children may destroy future molars;" © 2013 WebMD, LLC; Medscape Medical News; Apr. 8, 2013; www.medscape.com; pp. 1-2, USA.
- Kusek, K.; "Researchers use light to coax stem cells to repair teeth;" © 2013 President and Fellows of Harvard College; Harvard School of Engineering and Applied Sciences; Wyss Institute; May 28, 2014; <http://www.seas.harvard.edu/news/2014/05/researchers-use-light-to-coax-stem-cells-to-repair-teeth>; pp. 1-6; Cambridge/Boston, MA, USA.
- Levin, D.; "Nipping wisdom teeth in the bud: childhood anesthesia may thwart the development of third molars;" © 2014 Tufts University; Tufts Dental Medicine, Fall 2013; <http://now.tufts.edu/articles/nipping-wisdom-teeth-bud>; 1 page; Boston, MA, USA.
- Pogrel, M.A.; "What is the effect of timing of removal on the incidence and severity of complications?"; © 2012 American Association of Oral and Maxillofacial Surgeons; *Journal of Oral and Maxillofacial Surgery*; <http://dx.doi.org/10.1016/j.joms.2012.04.028>; vol. 70, No. 9, Supplement 1, Sep. 2012; pp. S37-S40; USA.
- Ricketts, R.M. et al.; "Third molar enucleation: diagnosis and technique;" *Journal—California Dental Association*; Apr. 1976; <http://www.ncbi.nlm.nih.gov/pubmed/1074850>; pp. 52-57; USA.
- Swee, J. et al.; "Inferior alveolar nerve block and third-molar agenesis: a retrospective clinical study;" © 2014 American Dental Association, all rights reserved; *JADA* 2013; 144(4); <http://jada.ada.com>; pp. 389-395; USA.
- Guralnick W.C. et al.; "Removal of third molars;" National Institutes of Health Consensus Development Conference Statement; Nov. 28-30, 1979; NIH Consens Statement Online Nov. 28-30, 1979; 2(11):65-68; USA.
- Pogrel, M.A. et al.; "White paper on third molar data;" American Association of Oral and Maxillofacial Surgeons; Mar. 2007; http://www.aaoms.org/docs/third_molar_white_paper.pdf; pp. 1-25; USA.
- Gordon N.C. et al.; "The effects of local hypothermia on odontogenesis;" Abstract; *Journal of Oral Surgery*, Apr. 1979; 37(4):235-44; PubMed—indexed for Medline; USA.
- American Dental Association, "Growth in dental spending expect to slow in 2009," American Dental Association, Feb. 26, 2009, 1 page, published at www.ada.org.
- Dodson et al.; "Introduction;" © 2012 American Association of Oral and Maxillofacial Surgeons; © 2012 American Association of Oral and Maxillofacial Surgeons <http://dx.doi.org/10.1016/j.joms.2012.04.022>; *Journal of Oral and Maxillofacial Surgery*, vol. 70, No. 9, Supplement 1, Sep. 2012; pp. S2-S3; USA.
- Dodson et al.; "Summary of the proceedings of the third molar multidisciplinary conference;" © 2012 American Association of Oral and Maxillofacial Surgeons; *Journal of Oral and Maxillofacial Surgery*, <http://dx.doi.org/10.1016/j.joms.2012.05.001>; vol. 70, No. 9, Supplement 1, Sep. 2012; pp. S66-S69; USA.
- AAOMS; "Advocacy White paper on evidence based third molar surgery;" American Association of Oral and Maxillofacial Surgeons; Nov. 10, 2011; USA.
- Silvestri et al., "Prevention of Third Molar Development in Dog with Long Pulse Diode Laser: A Preliminary Report," *Lasers Surg. Med.*, 2007; 39(8):674-7 (ISSN: 0196-8092). Boston, MA 02111, USA.
- American Association of Oral and Maxillofacial Surgeons, "White Paper on Third Molar Data," Article, Mar. 2007, 25 pages. Published at www.aaoms.org.
- American Public Health Association, "Opposition to Prophylactic Removal of Third Molars (Wisdom Teeth)," Policy Statement Database, Policy No. 20085, Oct. 28, 2008. Washington, DC 20001, USA.
- Askboots, "Removing Wisdom Teeth," Web Article, 9 pages, Sep. 21, 2007. BMJ Publishing Group Limited. Published at www.askboots.com.
- Bui et al., "Types, Frequencies, and Risk Factors for Complications After Third Molar Extraction," *Journal of Oral and Maxillofacial Surgery*, 2003; 61:1379-1389, Chapel Hill, NC 27599, USA.
- Dodson, T.B., "Response to APHA C3: Opposition to Prophylactic Removal of Third Molars," Article, Oct. 26, 2008, 3 pages, Massachusetts General Hospital. Boston, MA 02114, USA.
- Eklund et al., "Third-Molar Removal Patterns in an Insured Population," *Journal of the American Dental Association*, vol. 132, No. 4, 469-475, 2001.

(56)

References Cited

OTHER PUBLICATIONS

- Friedman, J.W., "Containing the Cost of Third-Molar Extractions: A Dilemma for Health Insurance," Public Health Reports, vol. 98, No. 4, pp. 376-384, Jul.-Aug. 1983. Los Angeles, CA 90057, USA.
- Huang et al., "Third-Molar Extraction as a Risk Factor for Temporomandibular Disorder," Journal of the American Dental Association, vol. 137, No. 11, pp. 1547-1554. American Dental Association, 2006.
- National Institutes of Health, "Removal of Third Molars," NIH Consensus Statement Online, Nov. 28-30, 1979; 2(11):65-8.
- Pratt et al., "Indications for Third Molar Surgery," J. R. Coll. Surg. Edinb., vol. 43., Apr. 1998, pp. 105-108. Portsmouth, UK.
- Silvestri et al., "Selectively Preventing Development of Third Molars in Rats Using Electrosurgical Energy," Journal of the American Dental Association, vol. 135, No. 10, 1397-1405. Boston, MA 02111, USA.
- Silvestri et al., "The Unresolved Problem of the Third Molar: Would People be Better Off Without It?" Journal of the American Dental Association, vol. 134, No. 4, 450-5. Boston, MA 02111, USA.
- U.S. Department of Labor, "Dentists," Webpage, 3 pages, last modified Dec. 17, 2009.
- University of York, The, "Prophylactic Removal of Impacted Third Molars: Is It Justified?" Effectiveness Matters, vol. 3, Issue 2, Oct. 1998. Heslington, York, UK.
- Wikipedia, "Third Molar," Wikipedia, Webpage, 9 pages, last modified Apr. 19, 2011.
- Wikipedia, "Tooth Development," Wikipedia, Webpage, 16 pages, last modified Apr. 18, 2011.
- Brace, C.L., "Microwave Ablation Technology Avoids Problems that Plague RFA, Offers Promise for New Applications," Diagnostic Imaging, Mar. 13, 2006, 2 pages. Madison, WI 53792.
- Brace et al., "Pulmonary Thermal Ablation: Comparison of Radiofrequency and Microwave Devices by Using Gross Pathologic and CT Findings in a Swine Model," Radiology, Jun. 2009, vol. 251, 705-11. Madison, WI 53792.
- Friedman, J.W., "Opposition to Prophylactic Removal of Third Molars," APHA Oral Health Section, Feb. 18, 2008, pp. 1-10.
- Kunkel et al., "Guideline: Surgical Removal of Third Molars," Agency for Quality in Dentistry, Apr. 2006, pp. 1-16. Cologne, Germany 50931.
- Park et al., "Cortical Integrity of the Inferior Alveolar Canal as a Predictor of Paresthesia After Third-Molar Extraction," Journal of American Dental Association, 2010; vol. 141, No. 3, 271-8.
- Wealthy Dentist, The, "Dental Marketing: Dentists Refer Some Wisdom Tooth Extractions to Oral Surgeons," pp. 1-5. Tiburon, CA 94920.
- Patent Cooperation Treaty, International Preliminary Report on Patentability, PCT/US10/34259, dated Aug. 31, 2011.
- Patent Cooperation Treaty, Written Opinion International Search Report, PCT/US10/34259, dated Sep. 14, 2010.
- AAOMS; "White paper on third molar data," Article, Mar. 2007, 25 pages. Published at www.aaoms.org.
- Patent Cooperation Treaty, "Notification of Transmittal of International Preliminary Report on Patentability," and "International Preliminary Report on Patentability," for PCT/US13/32357, at least as early as May 8, 2015, 14 pages.
- Blankenship et al., "Third Molar Development in the Estimation of Chronologic Age in American Blacks as Compared with Whites," Journal of Forensic Science, 2007; 52(2): 428-33. Memphis, TN 38163, USA.
- ITero, "OrthoCAD," "a digitally perfect orthodontic impression," www.cadentic.com, © 2009 Cadent, Ltd., 7 pages.
- ITero, "OrthoCAD," "a digitally perfect orthodontic impression," www.cadentic.com, © 2009 Cadent, Ltd., typed (Sep. 27, 2018) as a text document to provide a legible copy of the original document, 7 pages.
- Silvestri et al., "Prevention of Third Molar Tooth Development in Neonate Rat with a Long Pulse Diode Laser," Lasers Surg. Med., 2004, 35(5):385-91 (ISSN: 0196-8092), Boston, MA 02111, USA.
- X-Nav Technologies; "How It Works: X-Guide Dynamic 3D Navigation™ Workflow;" X-Nav Technologies; 2 pages; at least as early as 2020. <http://www.x-navtech.com/x-guide/how-it-works>.

* cited by examiner

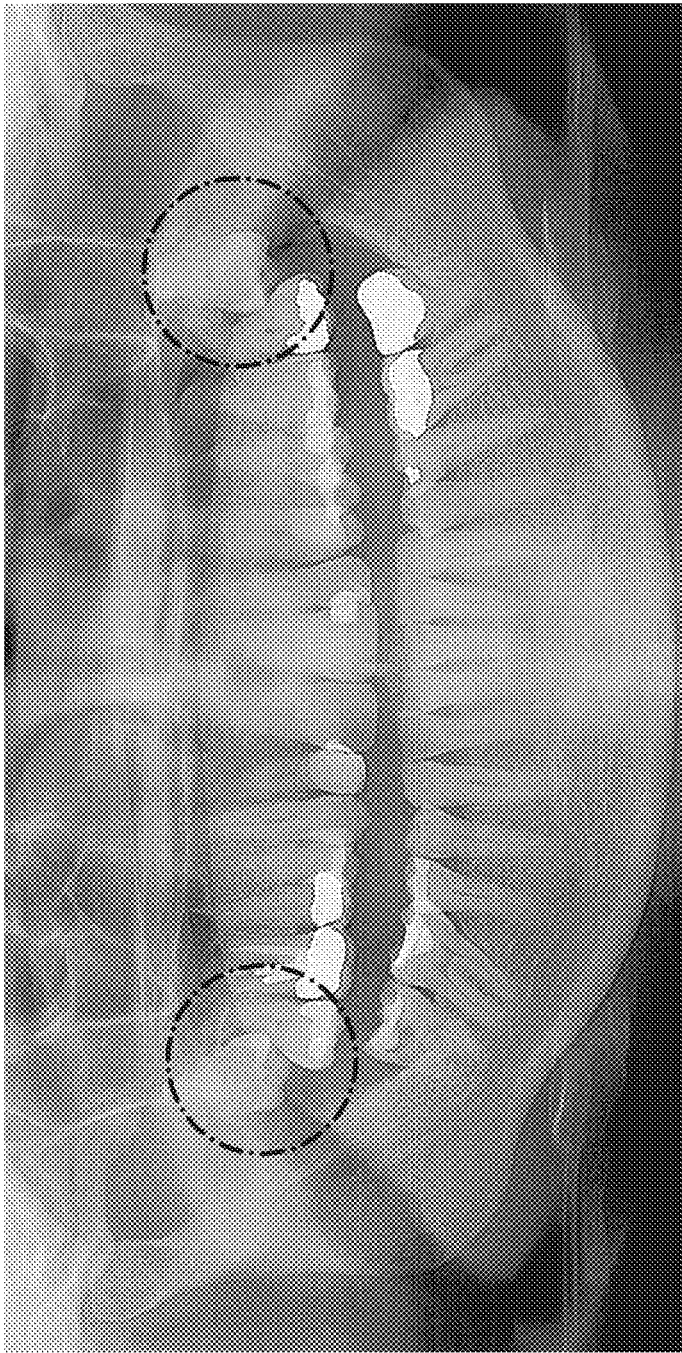

FIG. 1

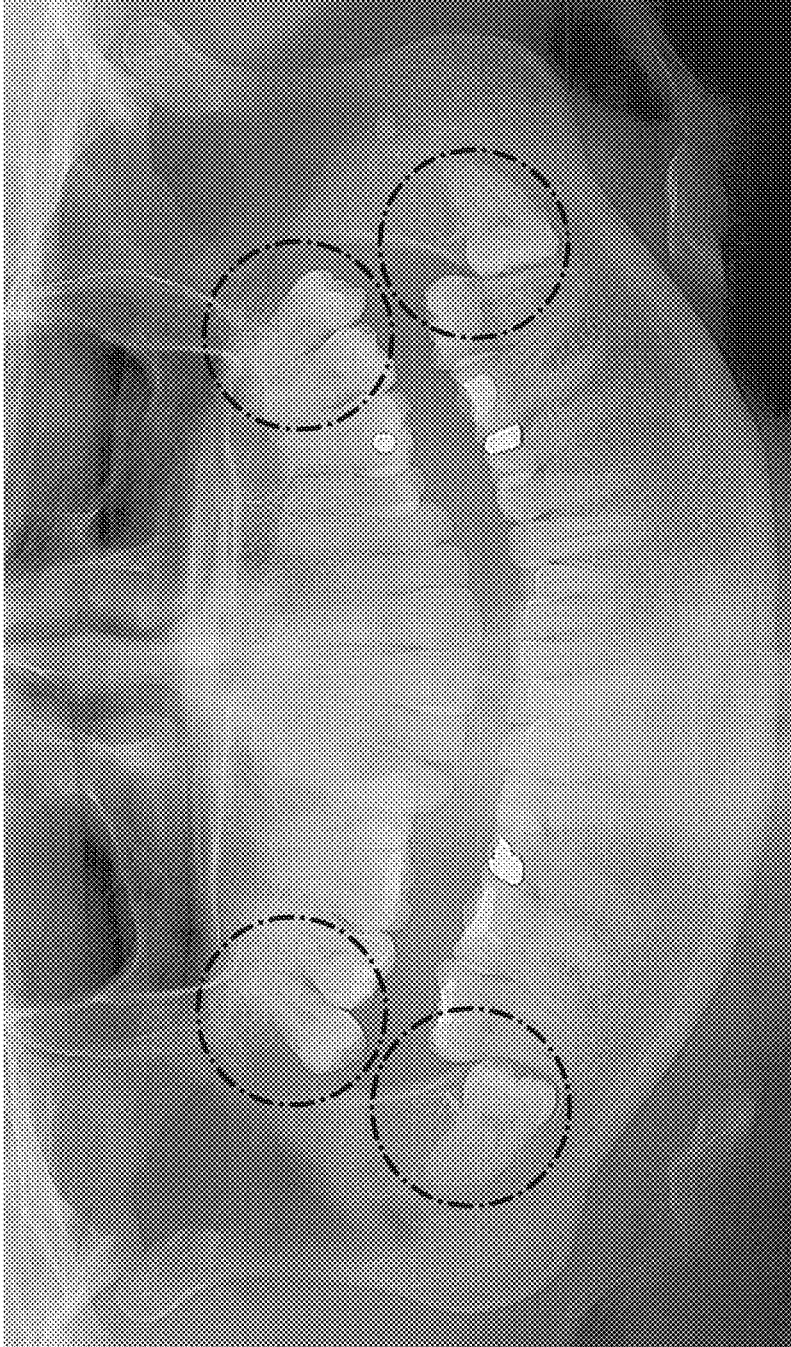

FIG. 2

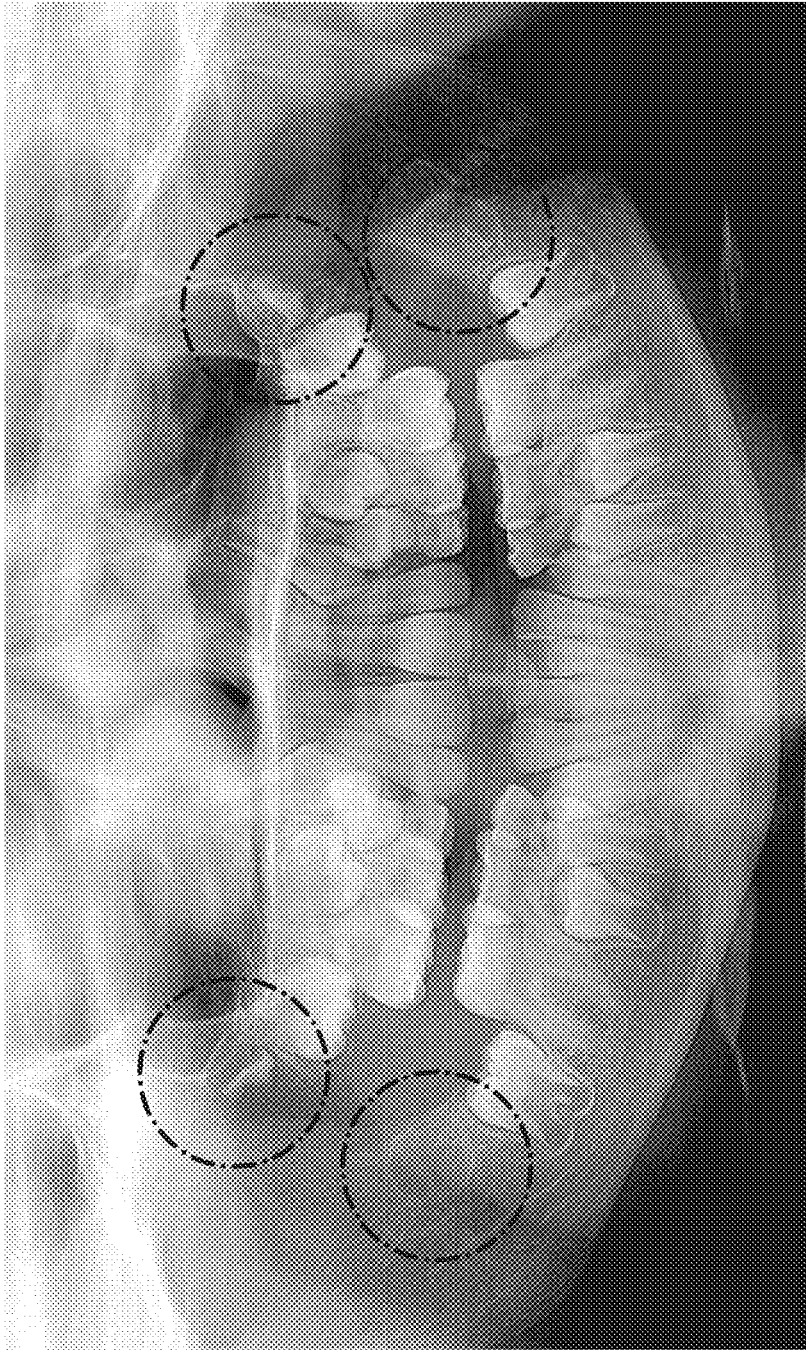

FIG. 3

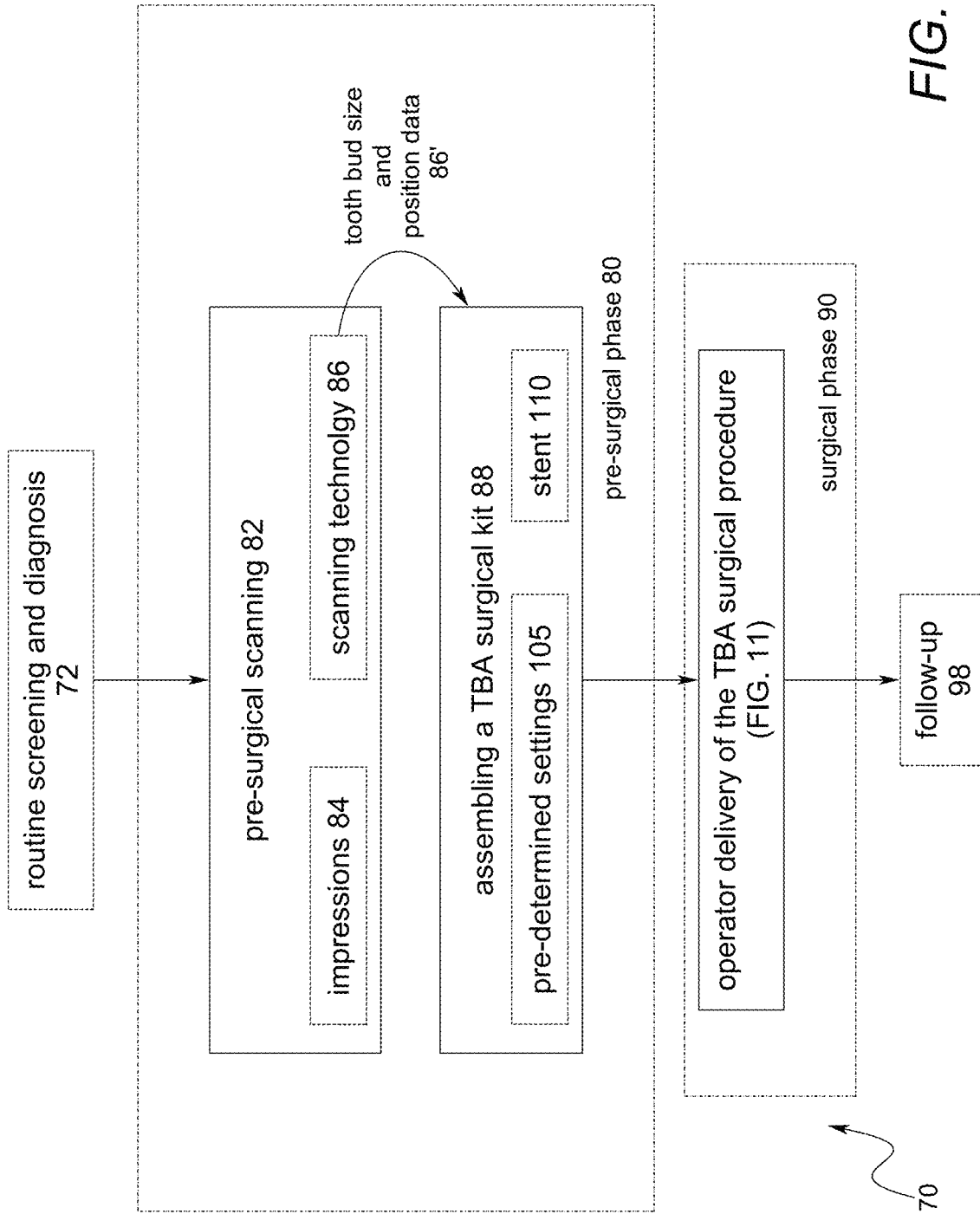

FIG. 4

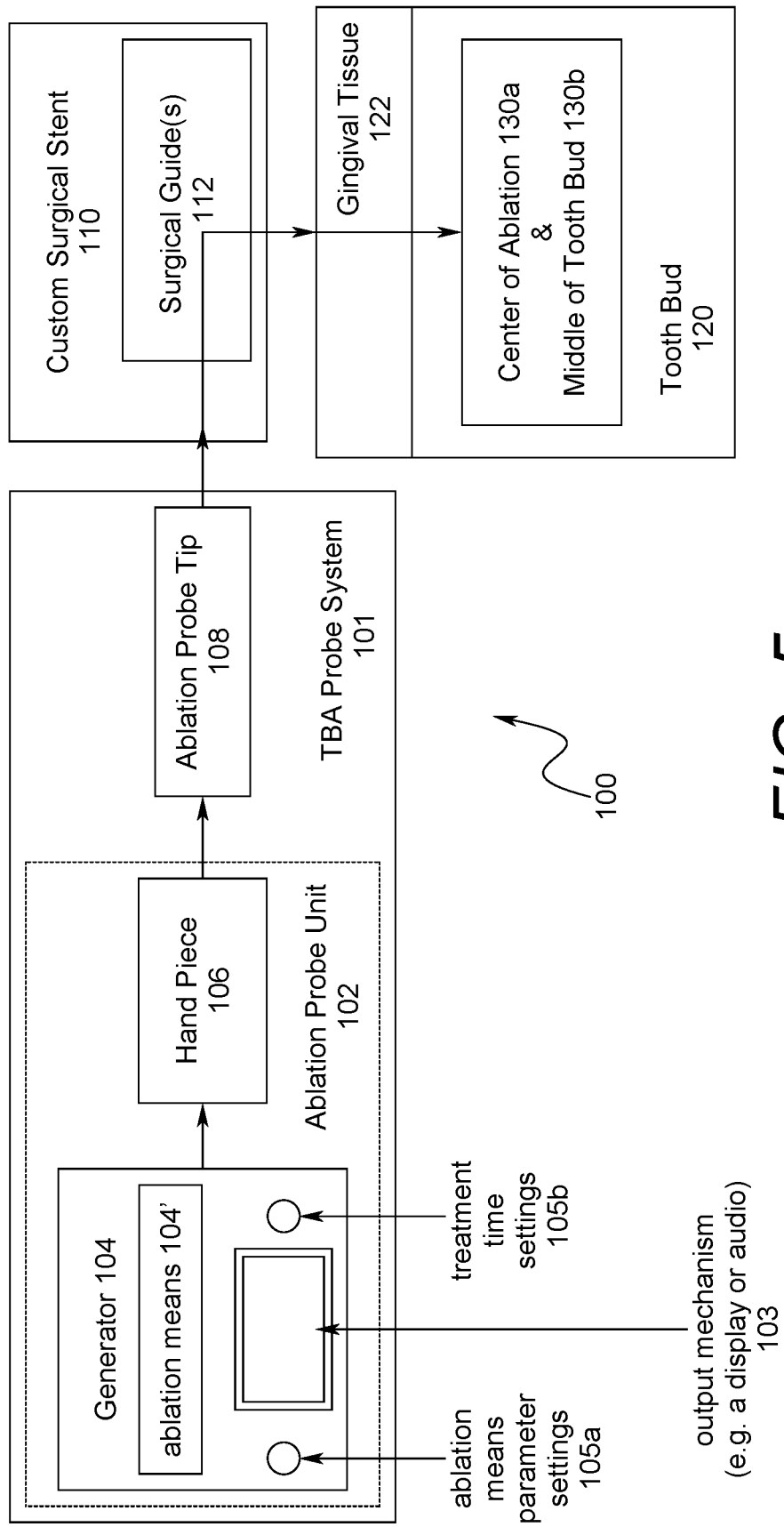

FIG. 5

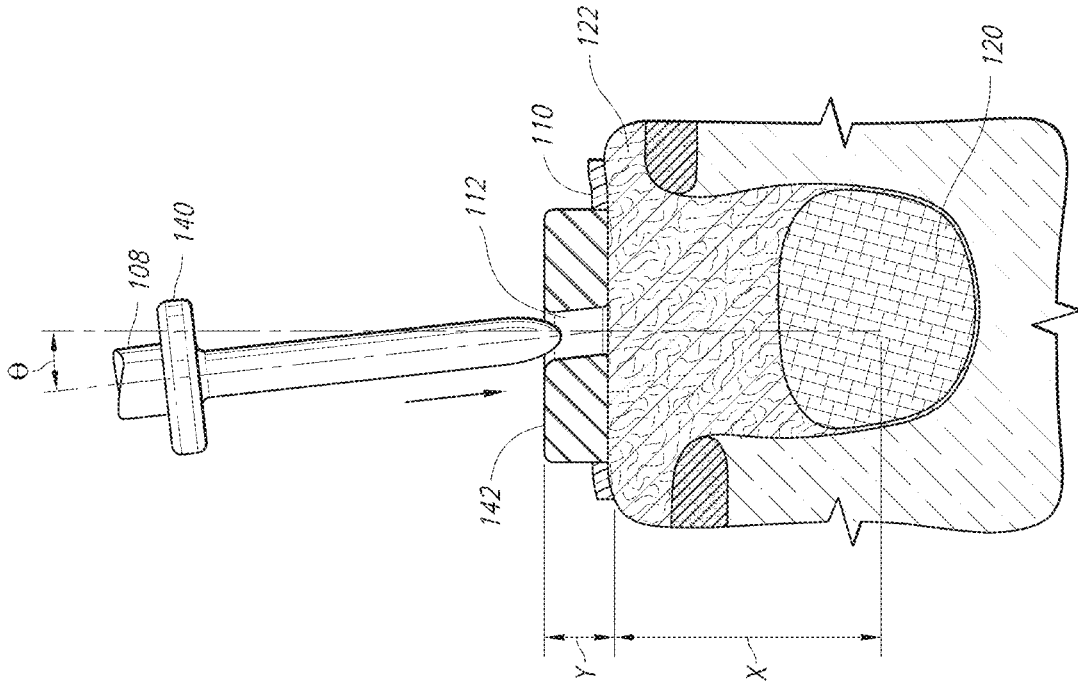

FIG. 6

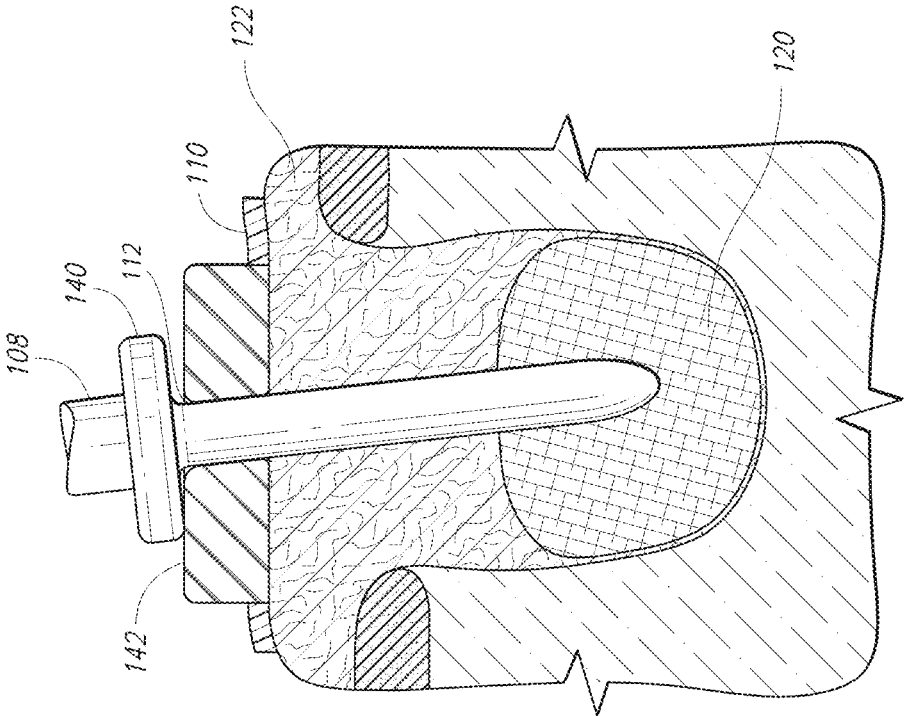

FIG. 7

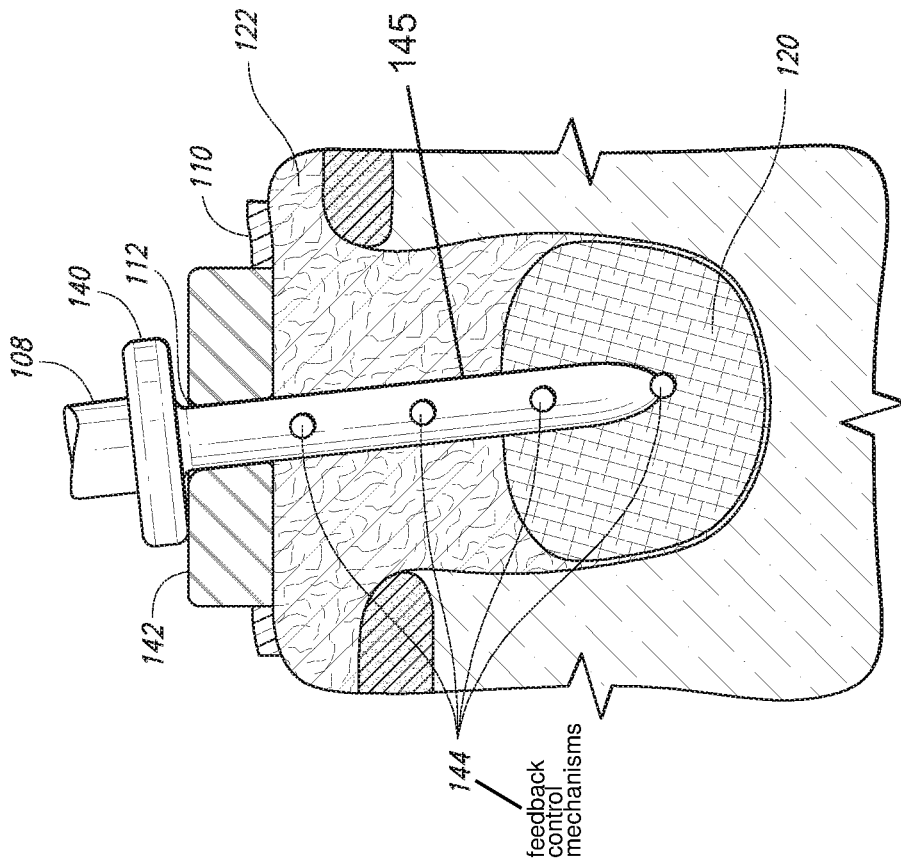

FIG. 8

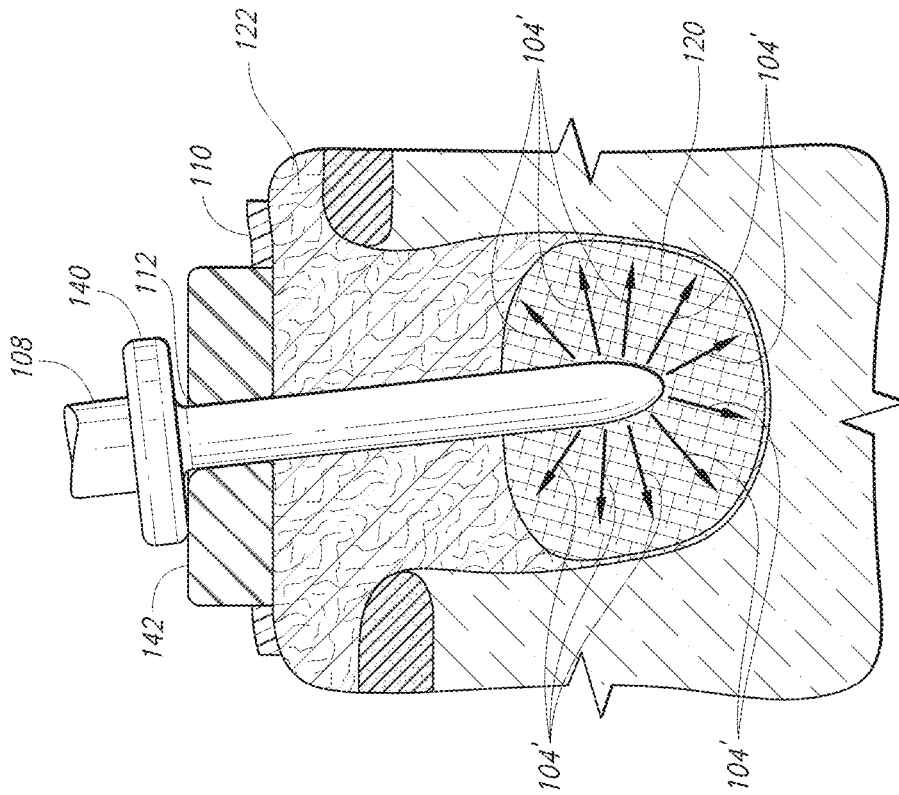

FIG. 9

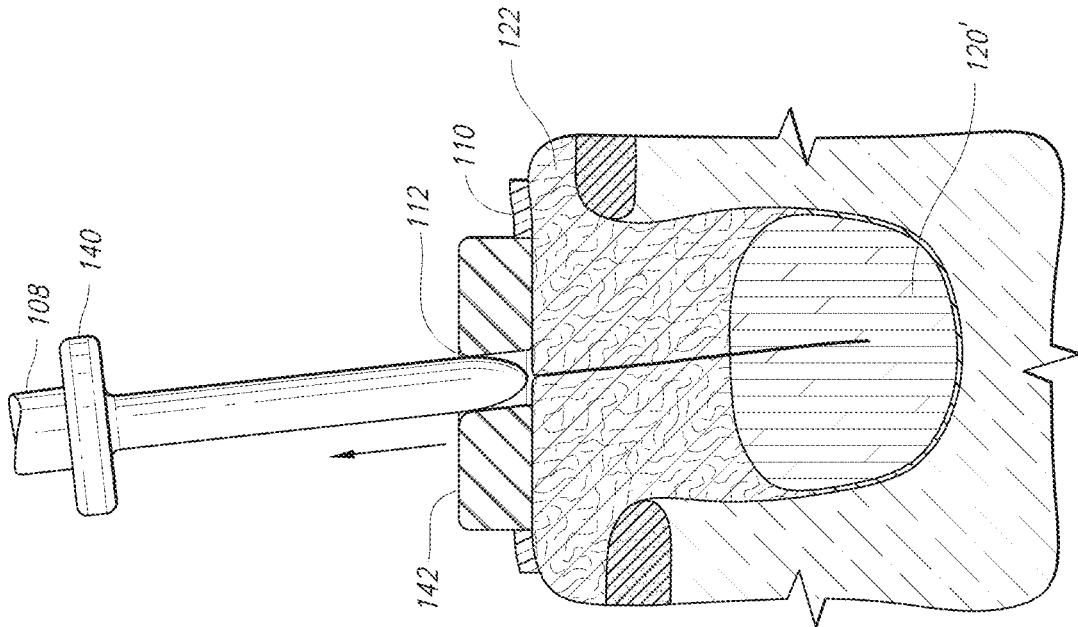

FIG. 10

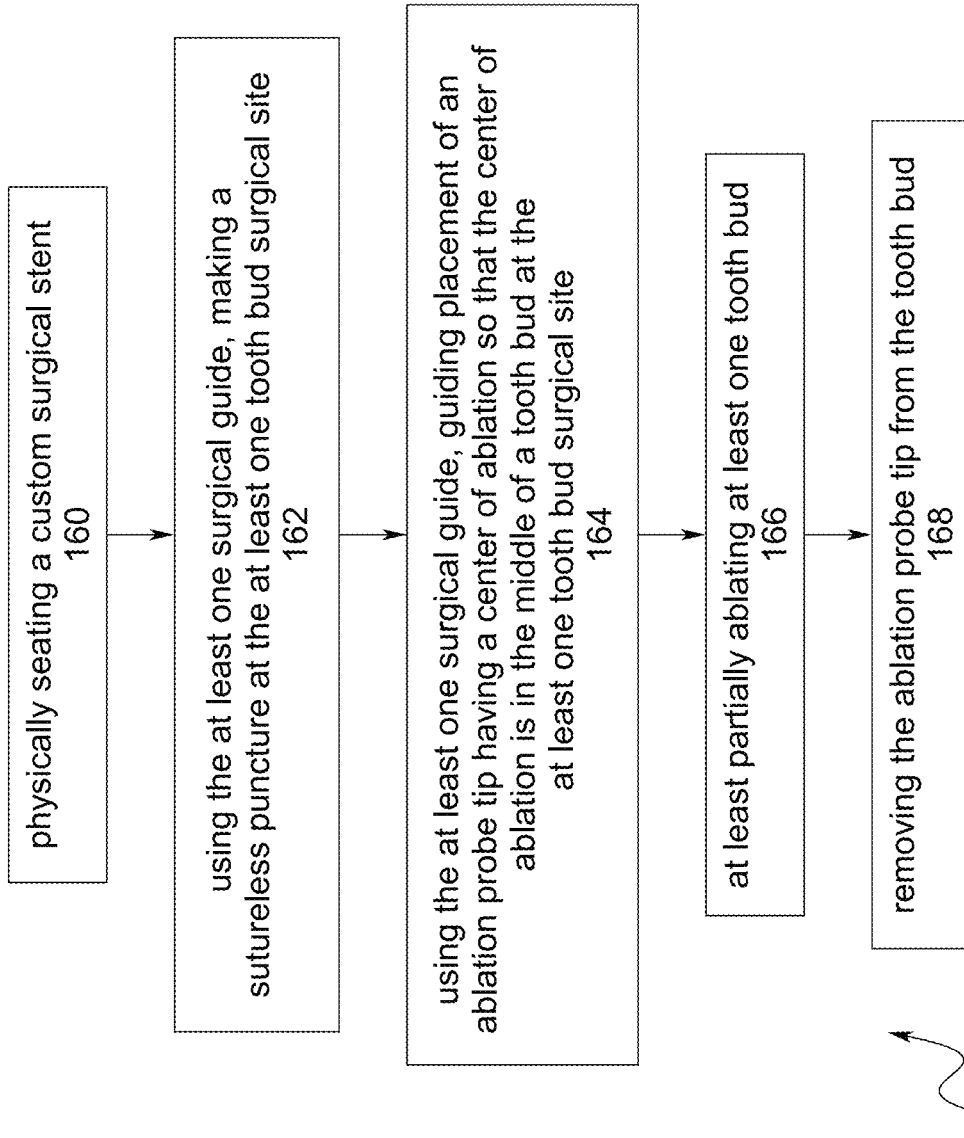

FIG. 11

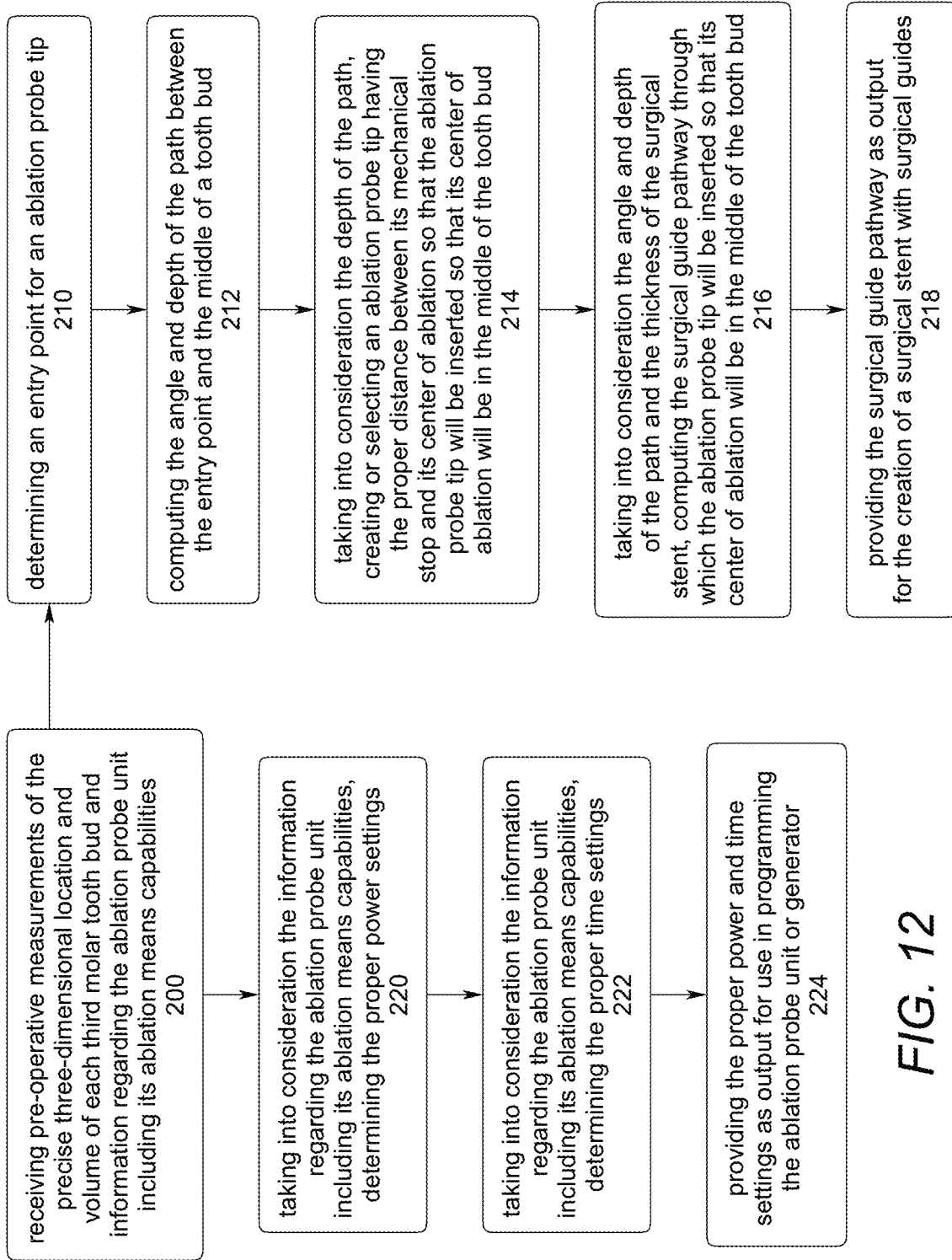

FIG. 12

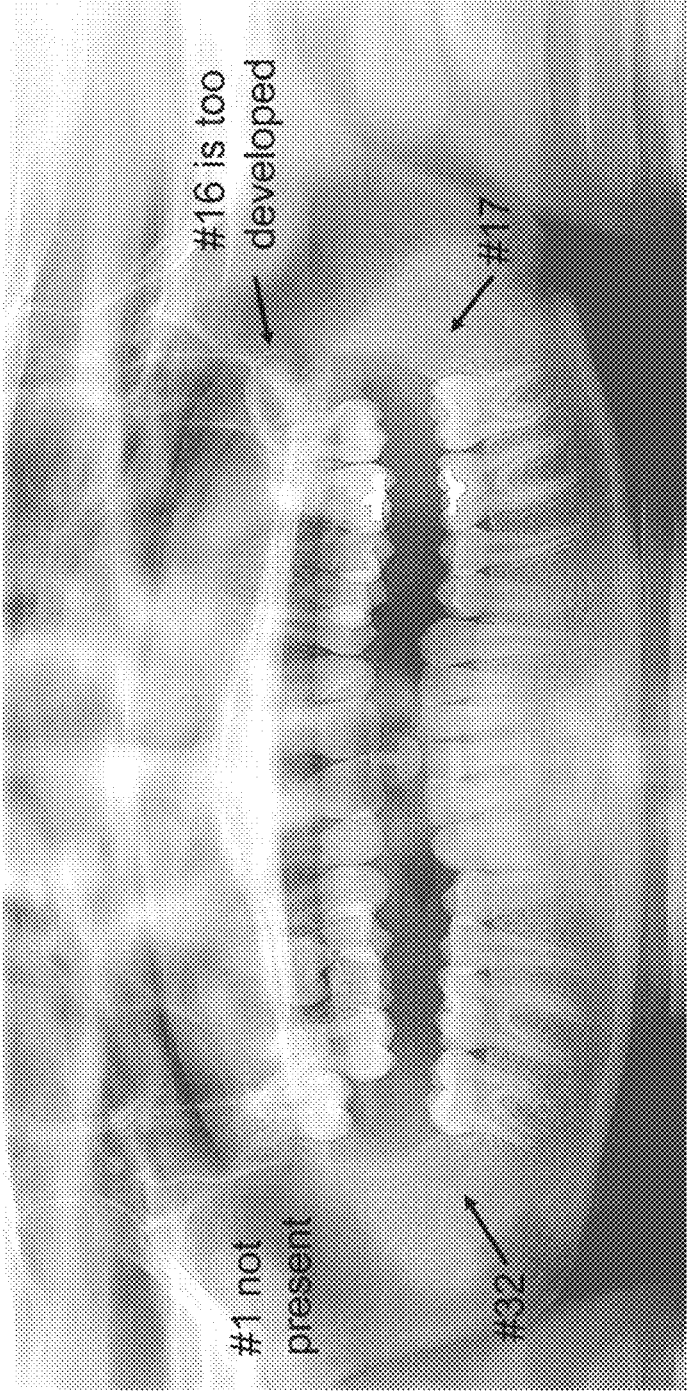

FIG. 13

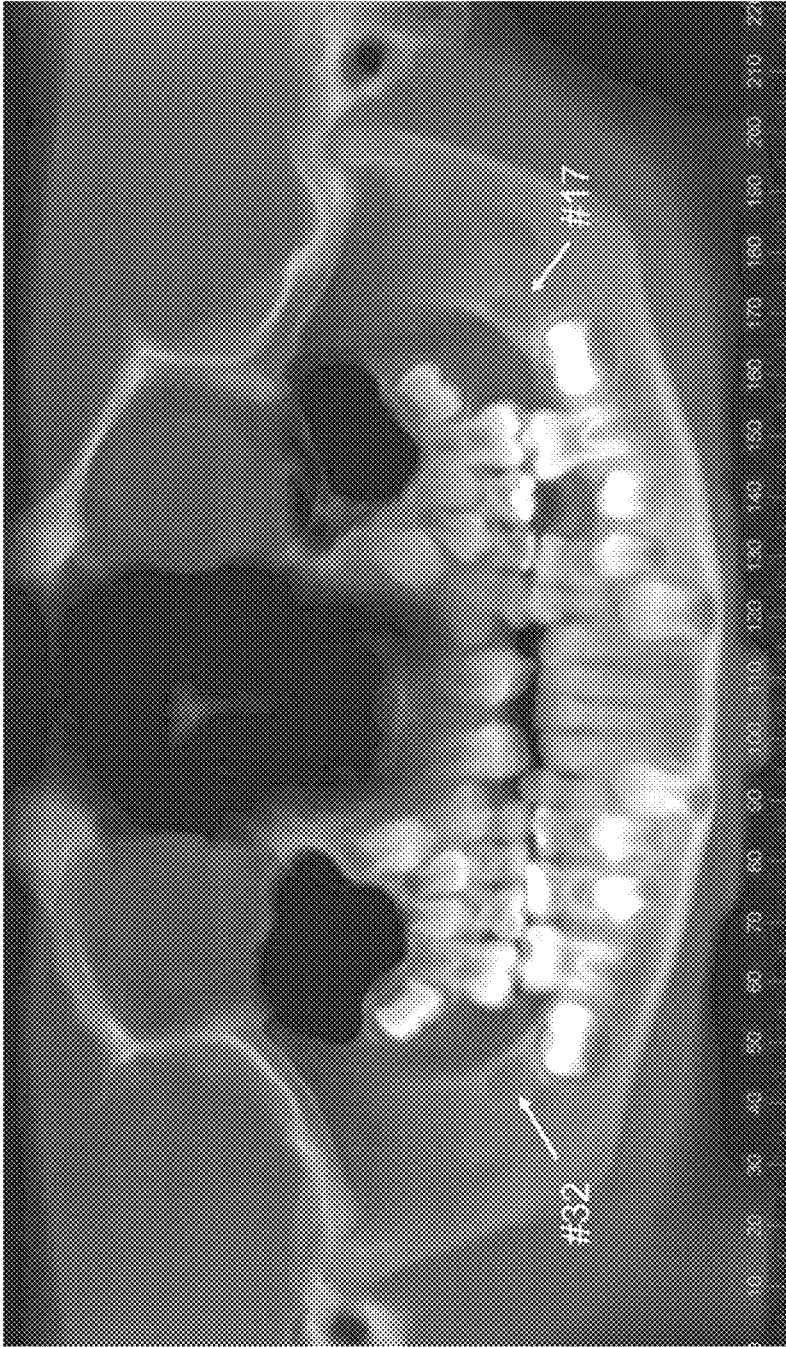

FIG. 14

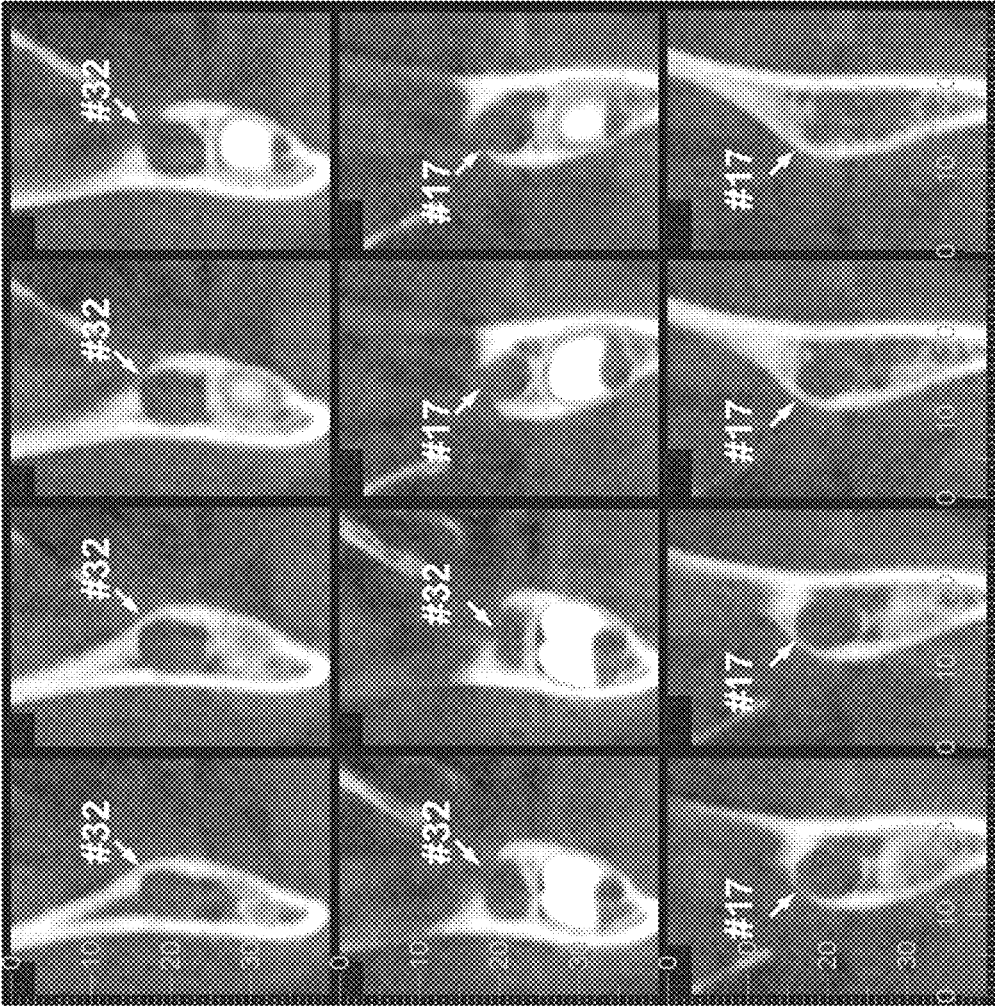

FIG. 15

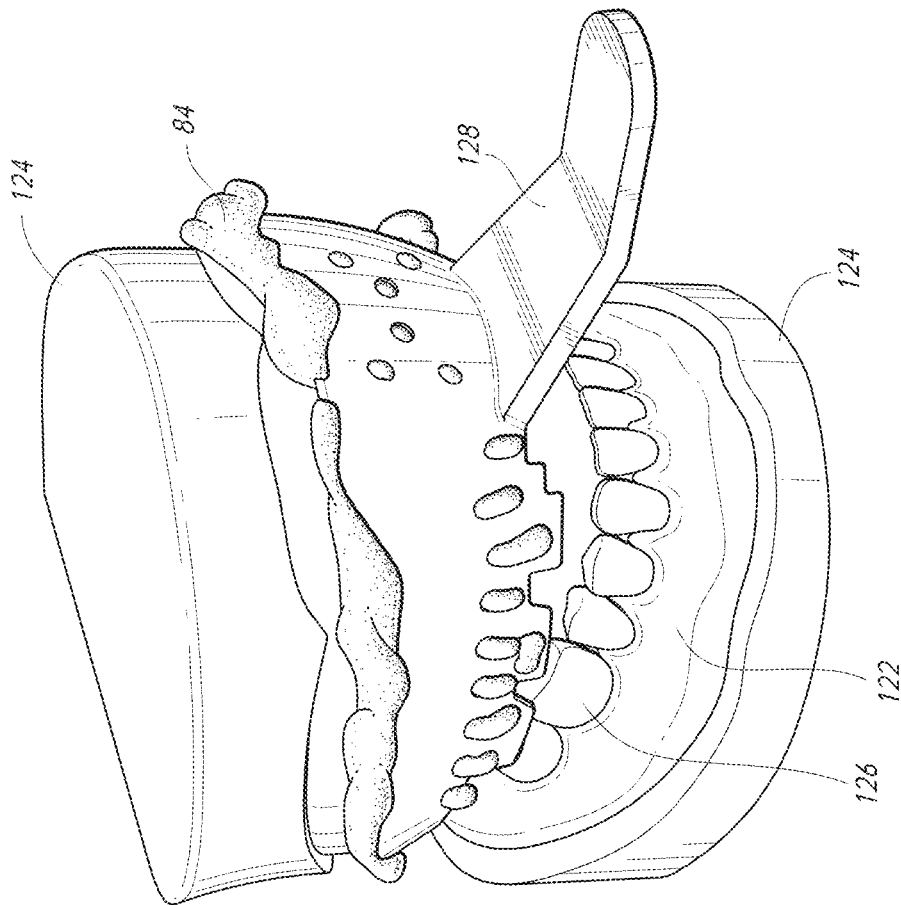

FIG. 16

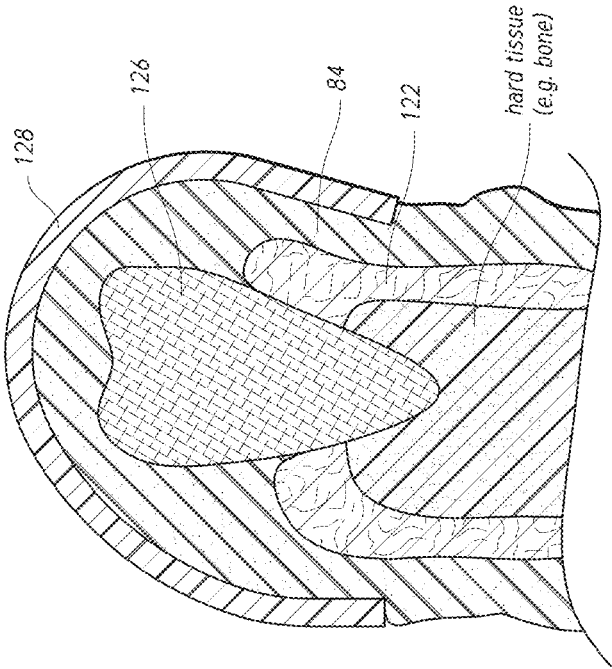

FIG. 17

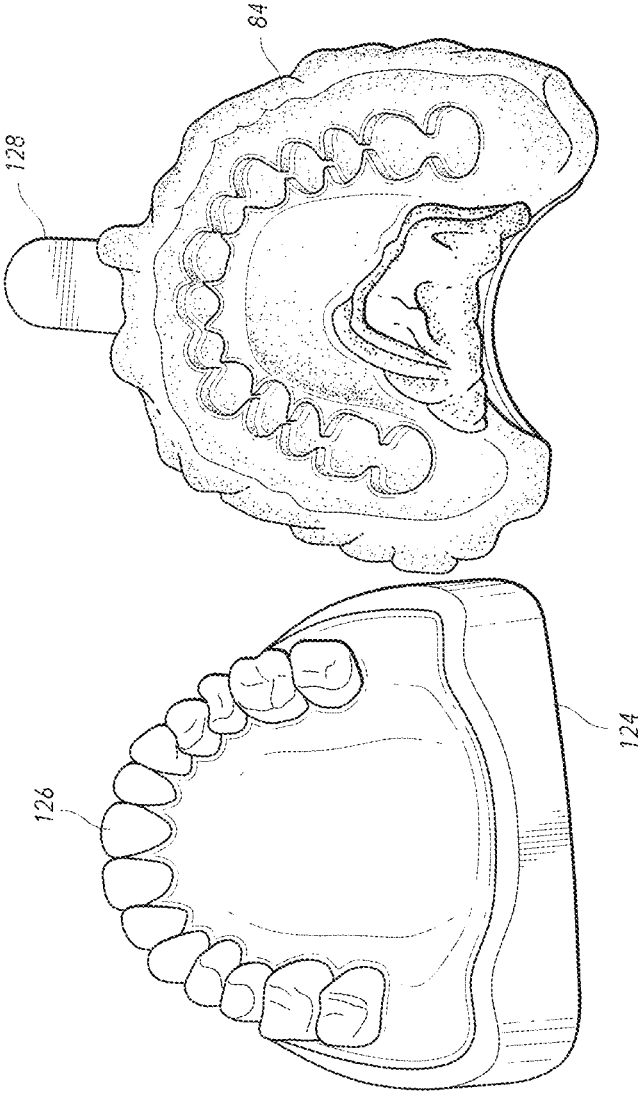

FIG. 18

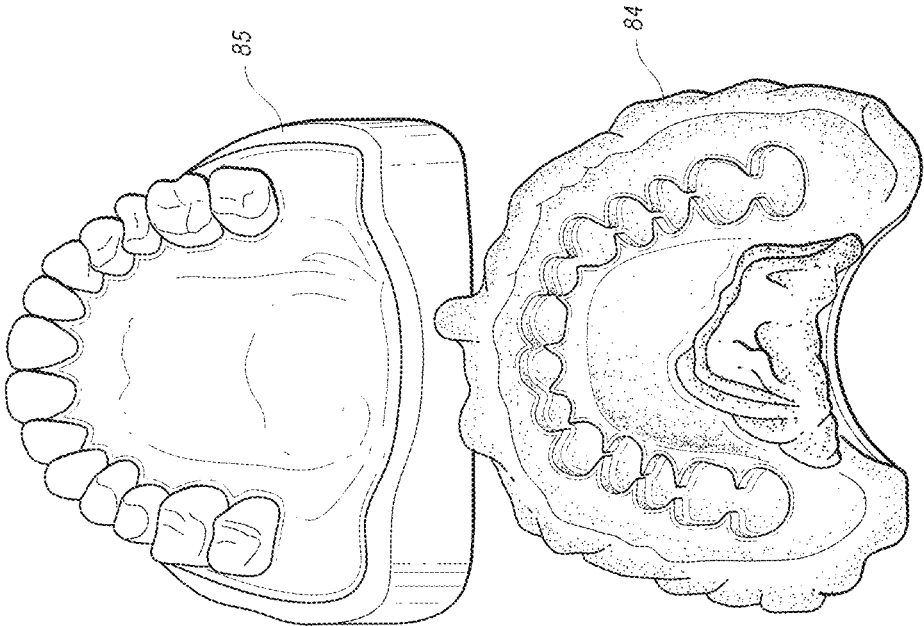

FIG. 19

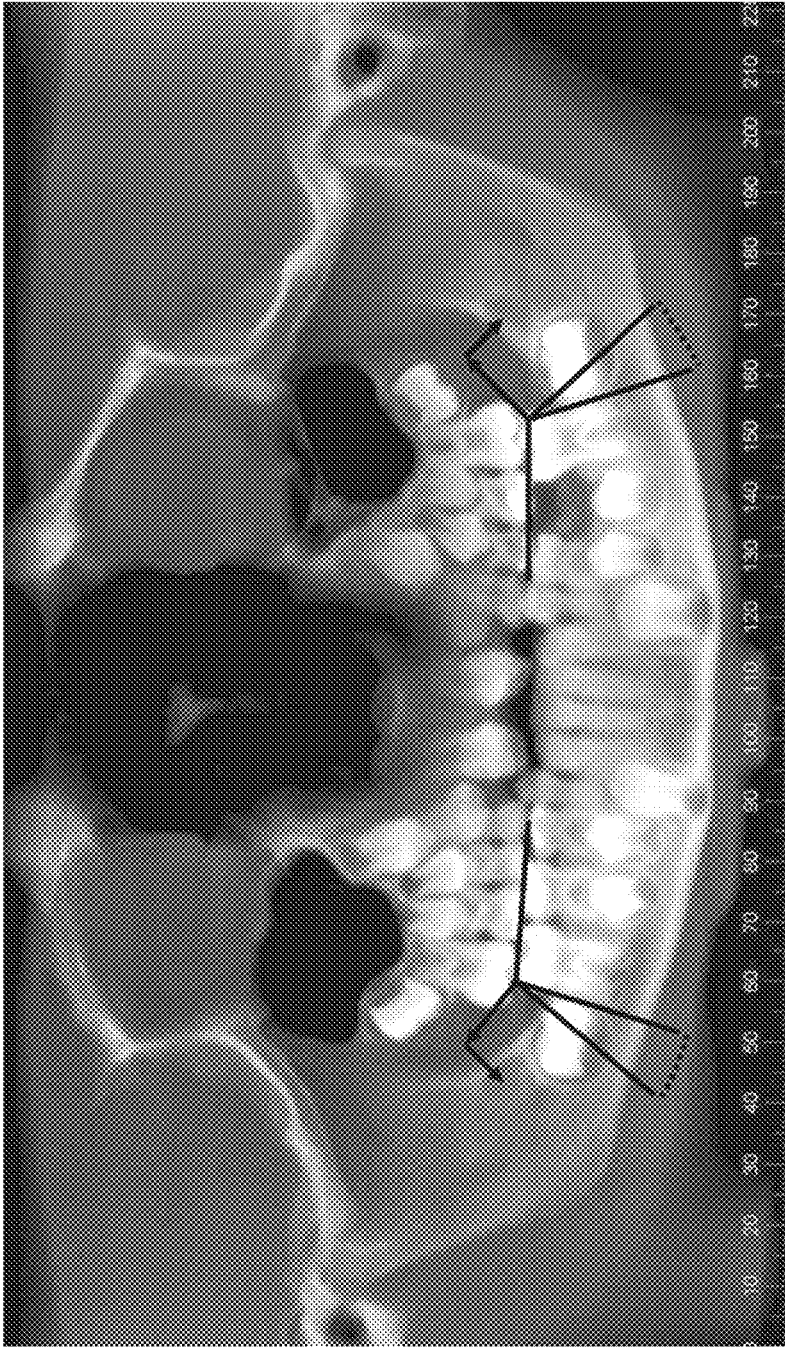

FIG. 20

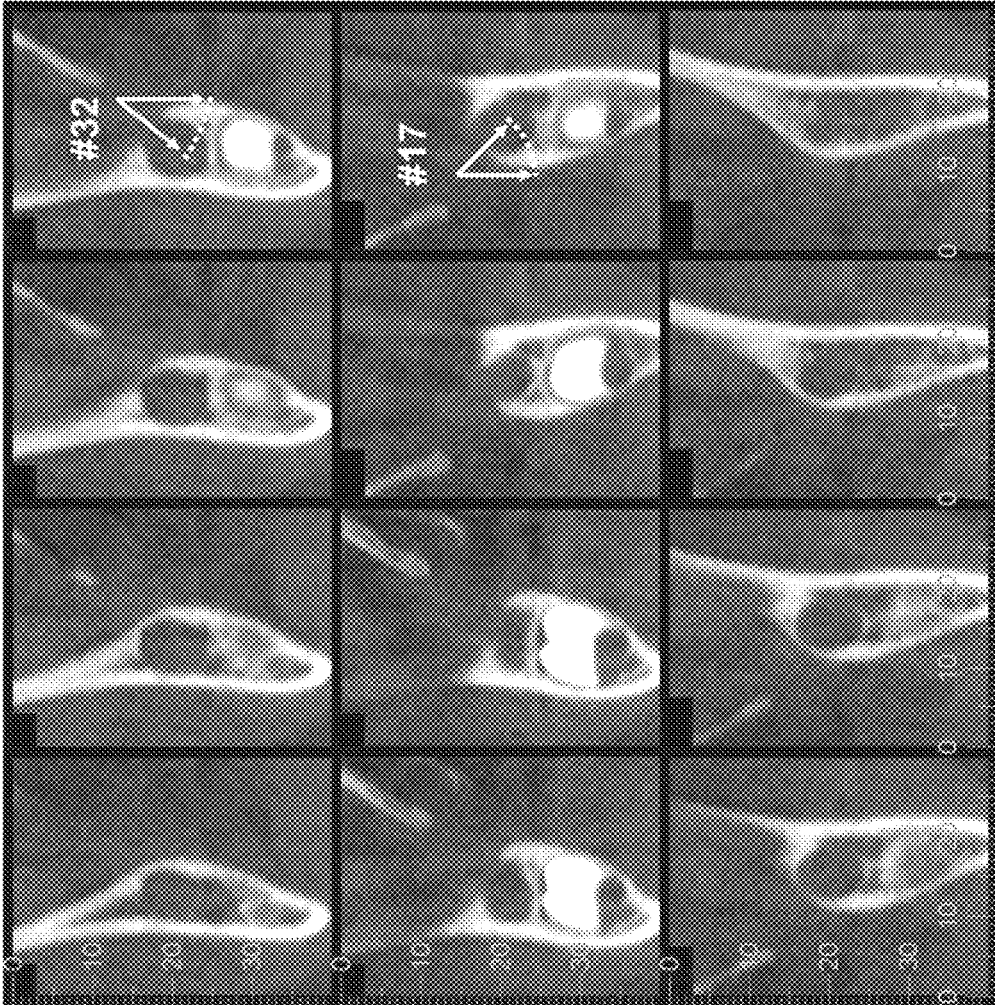

FIG. 21

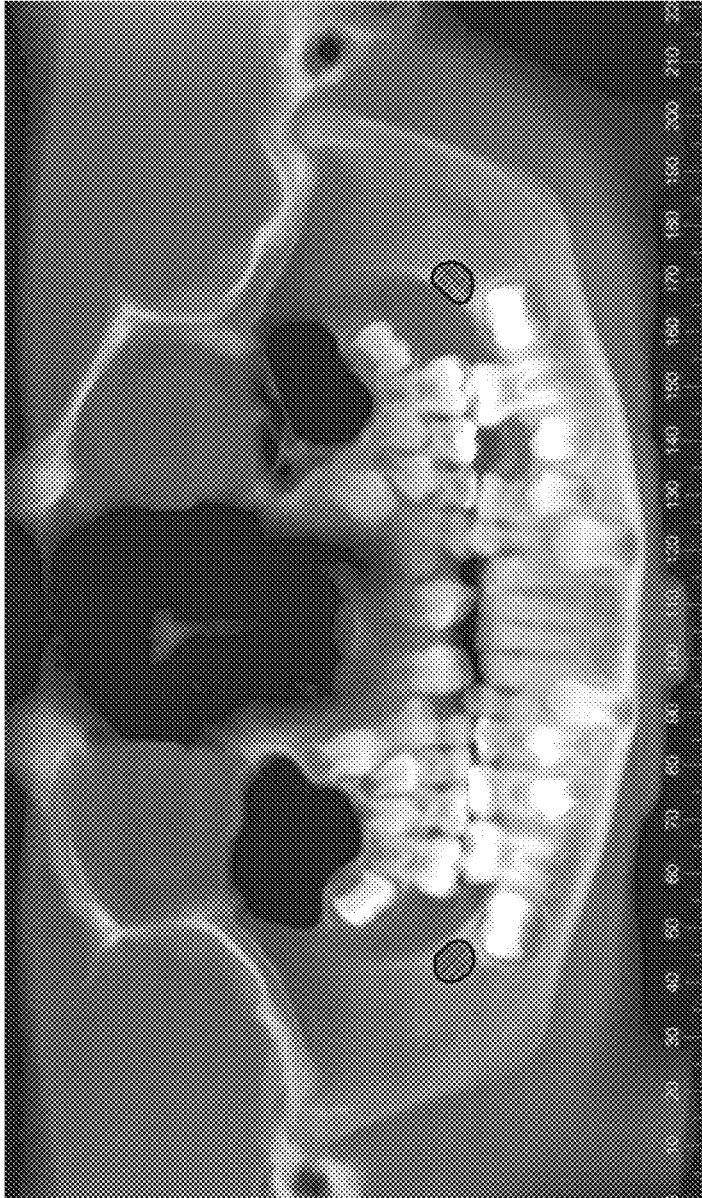

FIG. 22

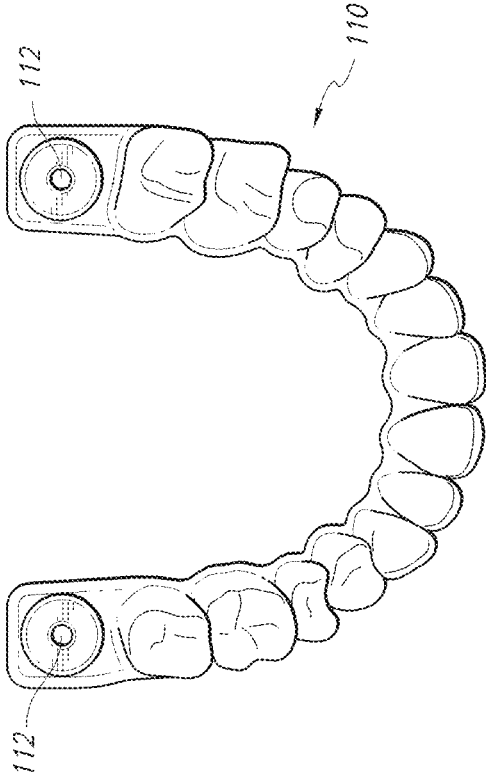

FIG. 23

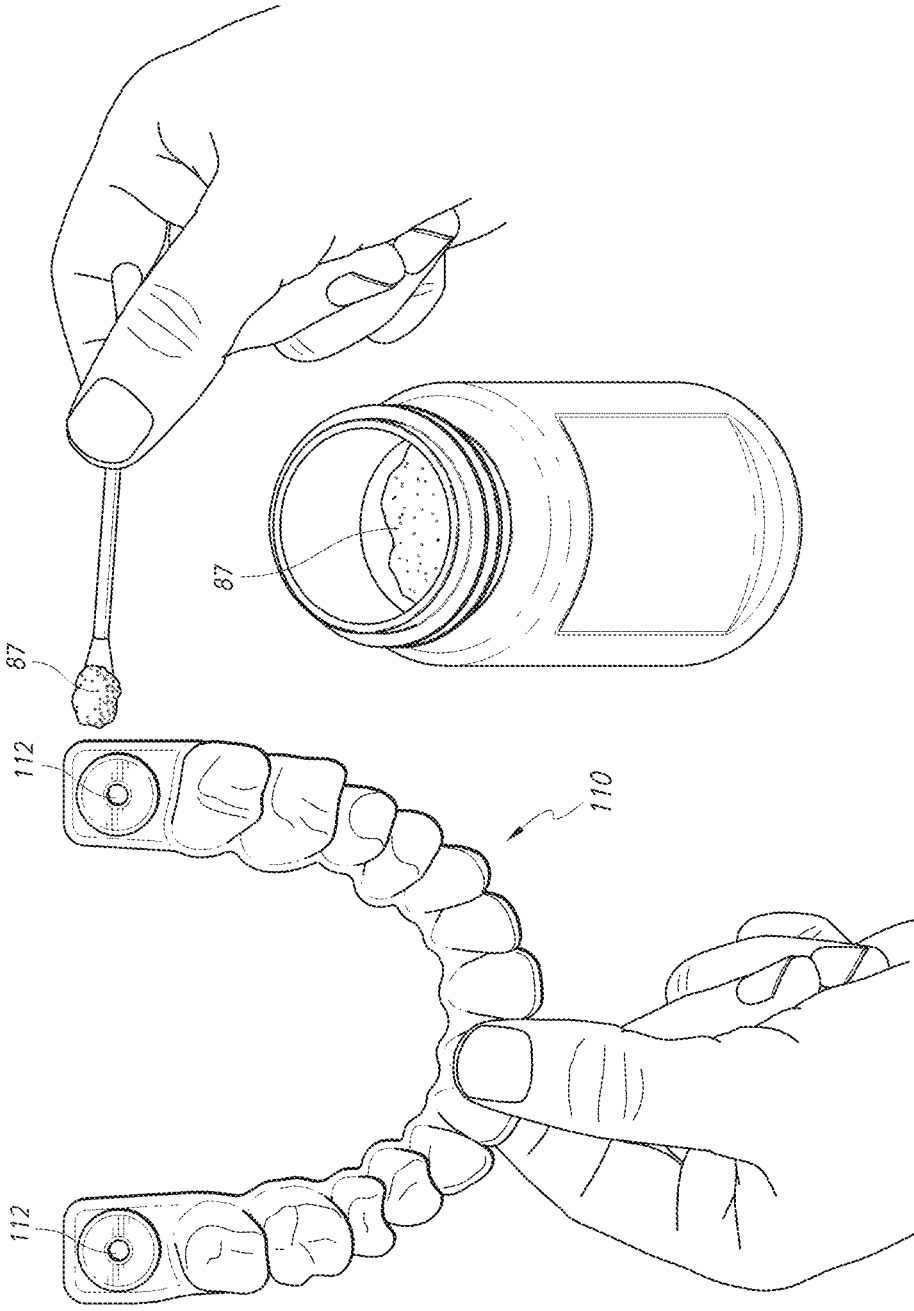

FIG. 24

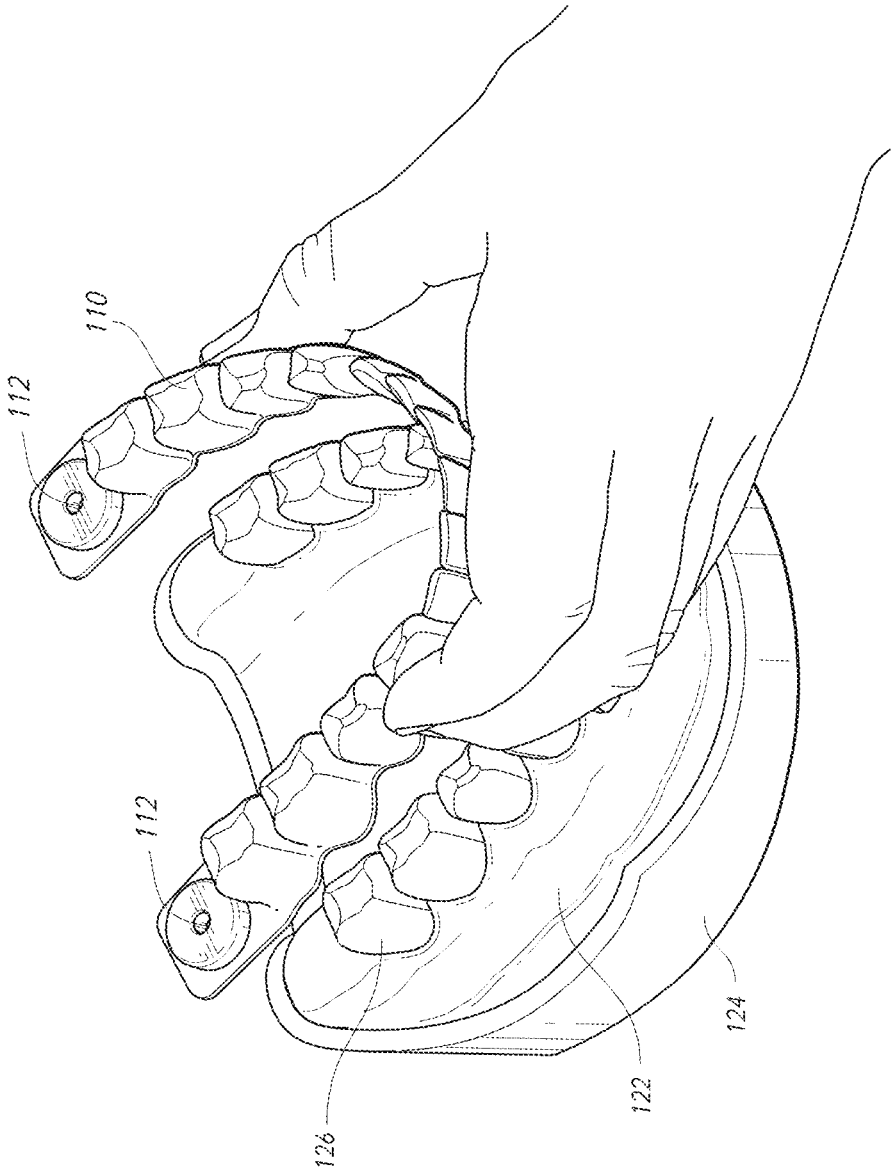

FIG. 25

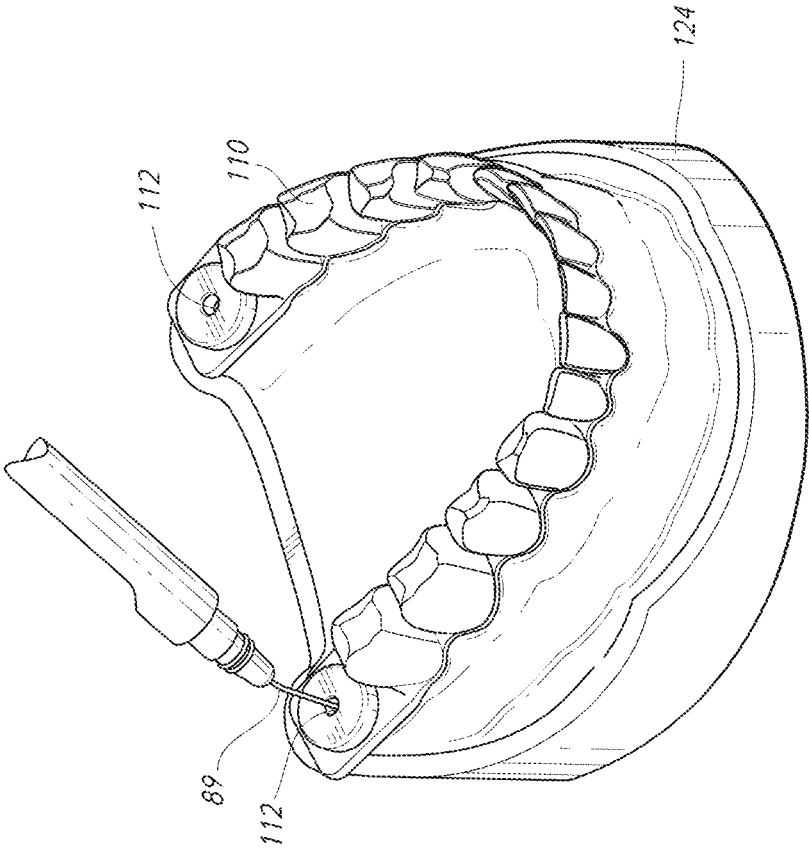

FIG. 26

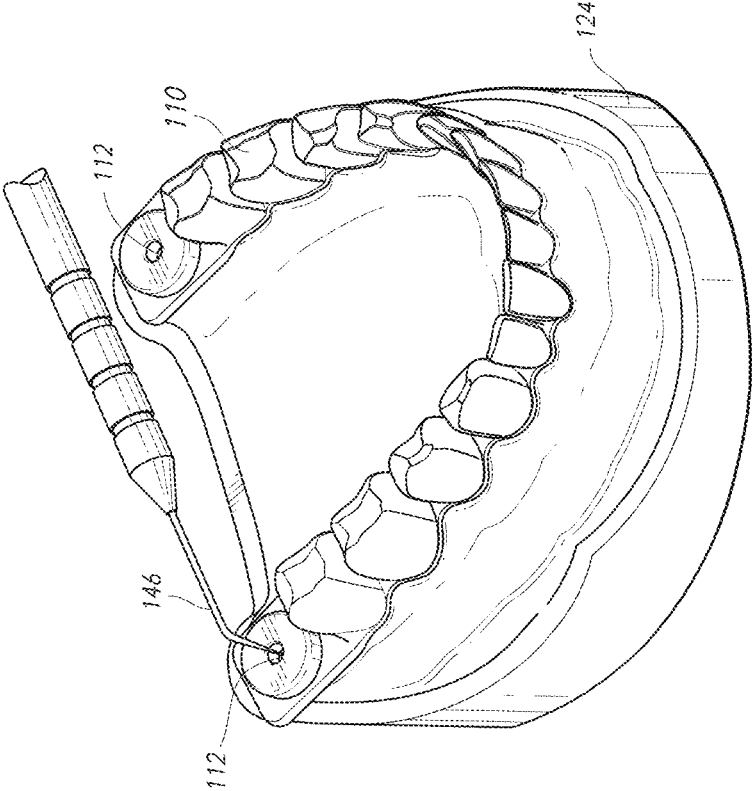

FIG. 27

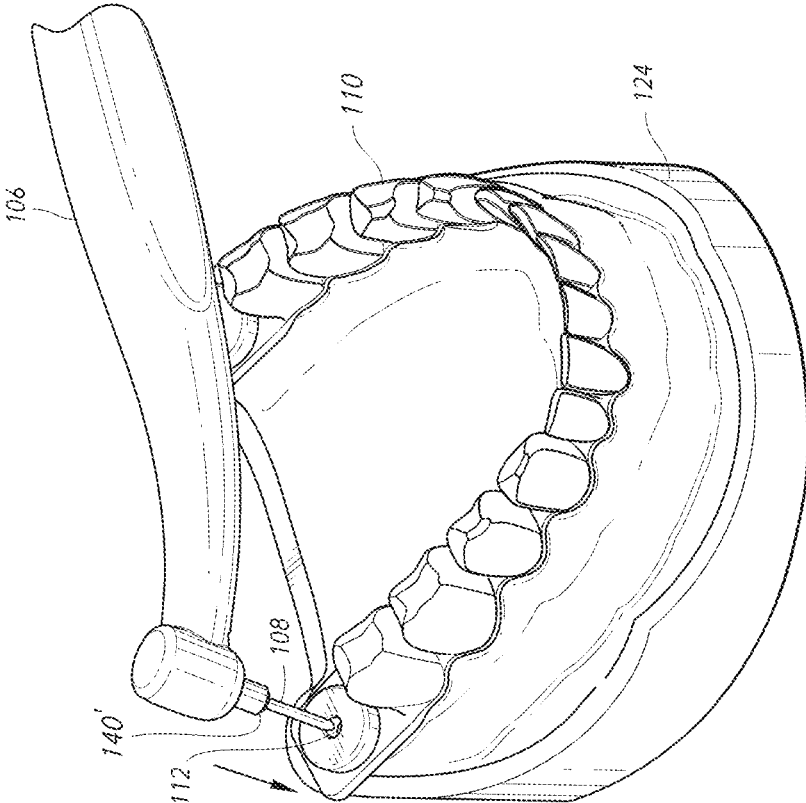

FIG. 28

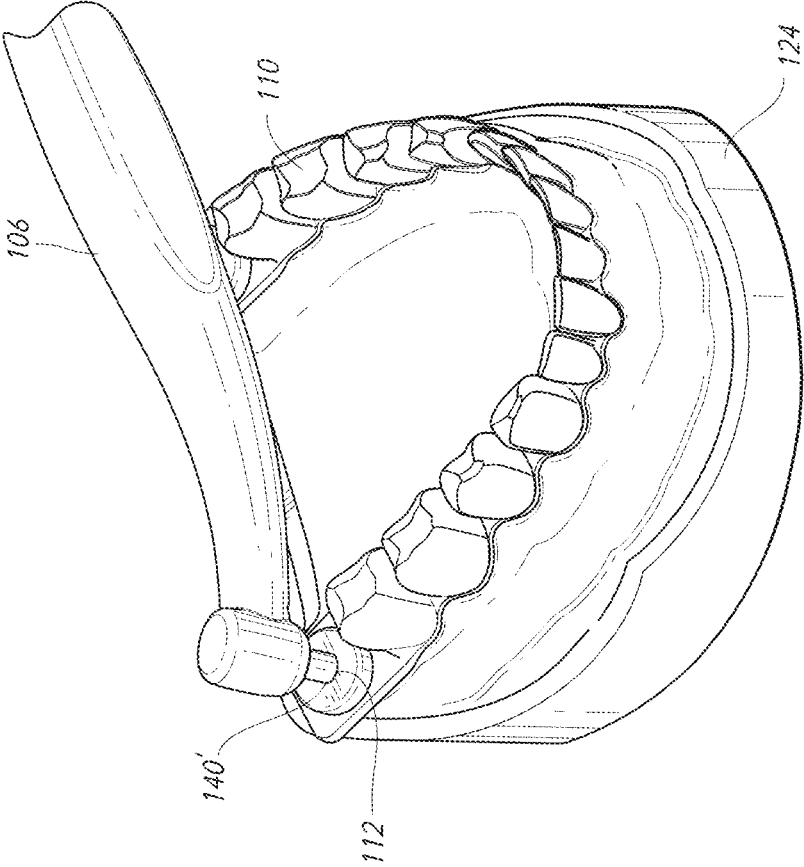

FIG. 29

THERAPEUTIC TOOTH BUD ABLATION

The present application is a continuation of U.S. patent application Ser. No. 12/863,183, filed Jul. 15, 2010, which is a national stage filing under 35 U.S.C. 371 of International Application No. PCT/US10/34259, filed May 10, 2010, which is an international application claiming the benefit under 35 U.S.C. Section 119(e) of U.S. Provisional Patent Application Ser. No. 61/177,143, filed May 11, 2009. The present application is also a continuation of International Application No. PCT/US10/34259, filed May 10, 2010, which is an international application claiming the benefit under 35 U.S.C. Section 119(e) of U.S. Provisional Patent Application Ser. No. 61/177,143, filed May 11, 2009. The present application is based on and claims priority from these applications, the disclosures of which are hereby expressly incorporated herein by reference in their entirety.

COPYRIGHT NOTICE

A portion of the disclosure of this patent document contains material that is subject to copyright protection. The copyright owner has no objection to the facsimile reproduction of the patent disclosure as it appears in the Patent and Trademark Office patent files or records, but otherwise reserves all copyright rights whatsoever.

TECHNICAL FIELD

Described herein are a tooth bud ablation (TBA) procedure and a tooth bud ablation (TBA) system.

BACKGROUND ART

Approximately 3.5% of the total \$100 billion spent on dental care in the United States in 2008 was for traditional surgical removal of third molars (i.e. “wisdom teeth” extractions), including the associated costs of imaging, sedation, and resulting complications. Traditional surgical removal of third molars, however, is a highly invasive, painful, and complication-ridden procedure. Further, third molar extraction represents the only procedure in the United States and Europe where it is considered “normal” to subject patients of any age group to such a highly invasive prophylactic surgery that carries significant lifelong risks for the excision of asymptotic or non-pathologic tissue. Dental practitioners (e.g. general dentists, pediatric dentists, and oral surgeons) have been trained to remove children’s wisdom teeth (third molars) before the wisdom teeth cause problems, but this surgery carries significant pain, risks, and costs.

The main problem associated with third molar tooth extractions—aside from the pain inflicted—is the serious risk of complications associated with such an invasive procedure. Each year “more than 11 million patient days of ‘standard discomfort or disability’—pain, swelling, bruising, and malaise—result post-operatively, and more than 11,000 people suffer permanent paraesthesia—numbness of the lip, tongue, and cheek—as a consequence of nerve injury during the surgery. At least two thirds of these extractions, associated costs, and injuries are unnecessary, constituting a silent epidemic of iatrogenic injury that afflicts tens of thousands of people with lifelong discomfort and disability.”

If you interview people under the age of 40 and ask them what has been the most invasive surgical procedure they have personally experienced (that is not trauma related), there is a greater than 90% chance that it will be their

“wisdom teeth” extraction. The current standard of care in America for “managing” third molars (e.g. “wisdom teeth”) in adolescents and young adults is generally to have all four third molars extracted once they are formed, unless it is absolutely clear that these teeth will erupt normally. General dentists and oral surgeons alike are complicit in their belief that third molars generally should be extracted because not all will erupt normally, thus causing future pathology.

Each year, an estimated 10 million third molar tooth extractions account for over 92% of all teeth extracted for patients under the age of 40. This represents surgery on approximately 5 million people each year at an estimated cost of over \$2.5 billion for third molar extraction fees alone in the United States. When IV sedation fees, X-ray imaging expenses, post-op medications, and unplanned post-operative expenses associated with treating complications are added in, the true United States health care cost is estimated to be well over \$3.5 billion. In addition to fee inflation, it has been shown that “upcoding” of wisdom teeth extraction (i.e. using an insurance code for payment of a higher fee than is clinically justified) has become an increasing problem for insurers. Insurance claims patterns clearly show that this procedure is largely treated as an elective procedure. The average annual income per oral surgeon has been estimated to be approximately \$500,000 for third molar extraction fees alone. Insurance companies have historically reported that reimbursement for third molar extractions has been the highest reimbursed surgical procedure even higher than hysterectomies in years when medical insurance used to pay for both procedures.

The market demographics and associated expenses are compelling. Over 77% of children at age 6 have all four third molar tooth buds radiographically detectable on routine panoramic X-rays (a type of volume scan). Over 90% of all teenagers in the United States have at least one third molar that will fully form. A typical cost for an oral surgeon to remove all four third molars on a teenager is generally \$2,000 to \$2,500 per patient once the teeth have at least partially formed—but before they have erupted—including the cost of IV sedation, consultations, and X-ray imaging costs.

There has been considerable controversy for the past fifty years regarding prophylactic extraction of third molars. A number of leading authorities have objectively tried to demonstrate that prophylactic extraction is a waste of health-care dollars, citing studies that indicate there is no objective scientific evidence for such a procedure, while other groups vigorously argue that prophylactic extraction in the teens and early adult years greatly eliminates more serious problems later in life and is worth the cost and risk.

An important question to ask is, “What happens if no prophylactic third molar extractions occur?” For instance, “as many as 22% of all emergency department visits” at a United States military support facility were related to dental problems, most of which were third-molar specific. In third-world countries, where prophylactic extraction of wisdom teeth is simply not performed, a high percentage of patients will present with acute infections, decay, gum disease and other problems later in life. In Jordan—where prophylactic extraction is not performed—46% of adult patients had pathology (decay, infection, bone loss, etc.) detectable on their third molars on routine X-rays and volume scans. Numerous studies show that third molars are hard to clean, generally do not erupt fully, and are the single most-likely teeth to have problems associated with them.

Routine panoramic X-rays of adults taken during a random two-week period are shown in FIGS. 1 and 2. These

X-rays show the examples of the range of problems that adult patients experience when they have third molars that are not extracted at an early age, including advanced decay and gum infections. For example, FIG. 1 shows a 48-year-old patient with both upper third molars present. There is a gum infection around both third molars that has caused 90% of the bone on the distal side of the second molars to be destroyed. In order to save the first molars, extraction of the second and third molars on the upper arch will be necessary. FIG. 2 shows another example in which a 36-year-old patient has all four third molars present. The upper third molars are hyper-erupting because they have no opposing teeth to occlude against. They will eventually need to be extracted. The lower third molars are horizontally impacted and show no signs of infection, but if they become infected, then the patient will almost certainly lose the adjacent second molars because of the bone damage that will occur.

The problem all practitioners face is that it is practically impossible to tell in advance which impacted wisdom teeth will ultimately cause future pathology. The reality is that most wisdom teeth (well over 50%) are surgically extracted prophylactically with no real knowledge that they will actually cause future pathology.

If pathology appears in patients over the age of 40, however, the stakes are much different. According to two prospective studies in the United States, in 1997 10.5% and in 2002 17.3% of patients requiring third molar extractions were over the age of 40. If a patient is presenting later in life to have one or more third molar extracted, it is because active pathology has been diagnosed, making surgery no longer elective. The attendant complication rates are not just higher, but these patients were categorized as “very high risk patients” for surgery. These studies concluded, “[t]he risk to patients and to the profession can be dramatically reduced by considering early removal of abnormal third molars” and “based on our experience, we propose extraction of third molars during adolescence when the X-ray indicates normal eruption cannot be expected due to lack of space or an abnormal position.”

The occurrence of post-operative complications is generally considered to be over 15% by most independent researchers. For instance, the formation of long-term periodontal pockets on the distal surfaces of second molars that results in gum disease, infection, and eventual second molar tooth loss is estimated to be over 10% due to the damage and poor bone morphology that result from third molar extraction surgery. The incidence of post-operative infections and “dry sockets” is generally accepted to be over 15%. Temporary paraesthesia due to damage to the mandibular nerve or the lingual nerve is over 10%, with residual permanent numbness of the lip or tongue present in approximately 1.5% of all patients. Recently, it has been concluded that approximately 23% of all cases of long-term Temporomandibular Joint (“TMJ”) dysfunction and chronic joint pain are attributable to third molar extraction surgeries.

Malpractice claims against dental practitioners relating to third molar extractions are at an all time high. Litigation for residual TMJ problems is increasing; in 2002 a North Carolina jury awarded \$5 million in damages to a patient with TMJ pain following third molar extractions. The incidence of litigation over permanent numbness of the lip has dramatically increased in recent years. Malpractice claims with resulting payouts have been reported to be as high as two-thirds of all claims made against dental practitioners when nerve damage is involved.

If the wisdom teeth are not extracted in adolescence, the roots will fully form, making future extraction difficult and

dramatically increasing the incidence of serious complications if surgery should later be required. The damage induced by long-standing, chronic infections in adults may necessitate the extraction not only of the third molars when they become symptomatic, but also of the adjacent second molars. Additional complications include the reduced healing response of adults as compared to adolescents, and the economic hardship induced by having to miss work. Many references indicate that prophylactic extraction of third molars in teens and young adults—in spite of the possibility of lifelong complications such as nerve damage—is justified to avoid the non-elective third molar extraction in adults over the age of 30.

Complications can be severe, even requiring hospitalization when teeth have been extracted on an out-patient basis. There have even been reports of patients who died as a direct result of wisdom tooth extractions.

As an example, FIG. 3 is an X-ray showing a 9-year-old patient with four third molar tooth buds present; three of them are in very early stages of enamel formation. The lower right third molar tooth bud does not have enamel formed yet, but will shortly. This X-ray shows an example of the early stages in which the tiny third molar tooth buds begin to form, begin to develop enamel, and finally begin to develop roots. Early signs of problems are almost always clearly evident by the time a patient is a teenager.

Once the tooth starts to form, the tooth bud starts to become encased in bone and appears to be “pushed down” into the mandible and maxilla as the child’s jaw bone grows out and around the tooth bud with age. Future surgical access becomes far more invasive as the bone encases the forming third molar. Given the basic physiology involved, early intervention is the only approach that will eliminate the complications and high costs associated with extraction of fully formed third molars later in life.

The idea of prophylactic third molar tooth bud removal is not new. In 1936, Dr. Henry supported the surgical enucleation of tooth buds, and it was again supported in the mid 70s by several practitioners using somewhat invasive surgical techniques to physically access the tooth buds and mechanically cut them out. In 1979, Drs. Gordon and Laskin used cryoprobes to enucleate third molar tooth buds in dogs. However, at the *NIH Conference On Third Molars* in 1979 it was concluded that “[a]lthough there are cogent reasons for early removal of third molars, the group felt that the suggested practice of enucleation of third molar tooth buds, based on predictive studies at age 7 to 9, is not currently acceptable.” (National Institutes of Health—Removal Of Third Molars Consensus Development Conference Statement—1979.)

Early removal of partially formed third molars (sometimes referred to as a “germectomy”) where the enamel of the crown has completely formed but less than one-third of the root length has formed, is demonstrated to be somewhat less invasive and carries no demonstrated long-term complications or risks associated with early-stage surgery. However, it is still highly invasive and generally requires IV sedation of the teenage patient. The American Association of Oral & Maxillofacial Surgeon’s White Paper On Third Molar Data references five studies involving over 1,100 germectomies with not a single case of a long-term complication (nerve injury, etc.) associated with the surgery. Further, since the germectomies were carried out on teenagers, there were no economic hardships induced by missing work. The White Paper understates the obvious conclusions associated with early intervention: “It does appear that early third molar removal may be associated with a lower inci-

dence of morbidity and also less economic hardship from time off work for the patient.” However, it can also be concluded that there is a tremendous conflict of interest because this paper was written by oral surgeons. To date there is still no measurable shift by dental practitioners to change the way in which third molars are screened, diagnosed, and extracted (i.e. early extraction), indicating that there is a need to fundamentally change the way this condition is being surgically managed.

There are a number of existing alternative technical approaches that can be considered for prophylactic enucleation of third molar tooth buds before the crown or root begins formation in children age 6 to 10. These technical approaches include ablation procedures using different types of ablation means. Exemplary ablation procedures include electrosurge tissue ablation (rats), cryoablation (dogs), laser ablation (dogs), and the use of a scalpel (humans). All but the first three ablation procedures (microwave ablation, radio frequency ablation, and irreversible electroporation) have significant limitations due to being highly invasive, high in cost, requiring cumbersome equipment, or due to the limited means of mechanical access in the oral cavity. Nor do these ablation procedures offer the potential for real-time feedback control to contain collateral tissue damage. To date, the only documented trial of any form of tooth bud ablation procedure utilizing ablation technology that is currently used in mainstream medicine is cryoablation (although preliminary animal trials have been completed using electrosurgical power and lasers).

The article entitled “Selectively Preventing Development Of Third Molars In Rats Using Electrosurgical Energy” by Silvestri et al. describes a pilot study that tests the hypothesis that third molars can be selectively prevented from developing. To test the hypothesis, a study was conducted in which thirty-three neonate rats received electrosurgical energy to the mucosal surfaces of one of their maxillary tuberosities. In this study, guides (insulating plastic positioning devices that housed the electrosurgical probes) were used. The guides were fabricated using the mouths of euthanized rat pups of the same age as the rats that were to be treated as a mold for creating the guides. Then, the electrosurgical probe placed so that its stainless steel tip extended less than 1.0 mm beyond the plastic positioning device to ensure contact with the external surface of the oral mucosa of the maxillary tuberosity. Finally, when in position, the rat pups received a single, unilateral, momentary pulse of monopolar electrosurgical energy to the external surface of the gum tissue of their maxillary tuberosity regions. It should be emphasized that this surface application of electrosurgical energy acted first to unnecessarily kill the overlying gum tissue, then bore a hole through the gum tissue, and otherwise damage not only the tooth buds, but other nearby tissue. The rats were cared for, but after the experimental period, were euthanized to determine the effectiveness of the procedure. The results were that ten rats showed no intra-oral or radiographic evidence of third molar development (and most of these rats subsequently developed palatal deformities), and six developed smaller-than-normal third molars. The conclusion was that maxillary third molars could be selectively prevented from developing in rat pups at or near the time of tooth bud initiation. It was recognized, however, that electrosurgical energy was too powerful and uncontrollable to reliably confine its damage to only the tooth-forming tissues.

SUMMARY OF THE INVENTION

Described herein is a tooth bud ablation procedure that results in tooth agenesis, including the steps of: (a) physi-

cally seating a custom surgical stent having at least one surgical guide so the at least one surgical guide corresponds to at least one tooth bud surgical site; (b) using the at least one surgical guide, making a surgical access path at the at least one tooth bud surgical site; (c) using the at least one surgical guide, guiding placement of an ablation probe tip having a center of ablation so that the center of ablation is in the middle of a tooth bud at the at least one tooth bud surgical site; and (d) at least partially ablating at least one tooth bud.

Described herein is a tooth bud ablation system for use in a tooth bud ablation procedure that results in tooth agenesis, the system including: (a) a custom surgical stent with at least one surgical guide corresponding to at least one tooth bud surgical site; (b) an ablation probe tip having a center of ablation; and (c) the at least one surgical guide having structure for guiding placement of the ablation probe tip so that the center of ablation is in the middle of a tooth bud by inserting the ablation probe tip through the at least one surgical guide.

Described herein is an ablation procedure including the steps of: (a) physically seating a custom surgical stent having at least one surgical guide so the at least one surgical guide corresponds to at least one lesion or tumor surgical site; (b) using the at least one surgical guide, making a surgical access path at the at least one lesion or tumor surgical site; (c) using the at least one surgical guide, guiding placement of an ablation probe tip having a center of ablation so that the center of ablation is in the middle of a lesion or tumor at the at least one lesion or tumor surgical site; and (d) at least partially ablating at least one lesion or tumor.

Described herein is an ablation procedure including the steps of: (a) physically seating a custom surgical stent having at least one surgical guide so the at least one surgical guide corresponds to at least one lesion or tumor surgical site; (b) using the at least one surgical guide, guiding placement of an ablation probe tip having a center of ablation so that the center of ablation is in the middle of a lesion or tumor at the at least one lesion or tumor surgical site; and (c) at least partially ablating at least one lesion or tumor.

Described herein is a method for volume scanning both hard tissues and soft tissues of a patient, the method including the steps of: (a) using an impression of a material visible in a volume scan; (b) generating a volume scan in which hard tissue is visible and the impression is visible, and soft tissue being “visible” as the space between the visible hard tissue and the visible impression; and (c) providing results of the step of generating a volume scan for the purpose of manufacturing or fabricating a custom surgical stent having at least one surgical guide for guiding placement of an ablation probe tip.

Described herein is a method for simultaneous volume scanning of both hard tissues and soft tissues, the method including the steps of: (a) using a dental impression of a material visible in a volume scan; (b) physically seating the dental impression in a patient’s mouth; (c) volume scanning the patient’s mouth while the dental impression is seated therein; (d) the step of volume scanning generating a volume scan in which hard tissue is visible and the dental impression is visible, and soft tissue is “visible” as the space between the visible hard tissue and the visible dental impression; and (e) providing the results of the step of volume scanning for the purpose of manufacturing or fabricating a custom surgical stent having at least one surgical guide for guiding placement of an ablation probe tip.

Described herein is a method for manufacturing or fabricating a custom surgical stent, the method including the steps of: (a) using a volume scan image in which hard tissue is visible and a dental impression is visible, and soft tissue is “visible” as the space between the visible hard tissue and the visible dental impression; and (b) manufacturing or fabricating a custom surgical stent with at least one ablation probe tip guide for guiding at least one ablation probe tip to a pre-defined angle and depth of ablation based on information obtained from the volume scan image.

Described herein is a tooth bud ablation procedure that results in tooth agenesis, including the steps of: (a) pre-operatively taking measurements to determine a three-dimensional location of the middle of a tooth bud; (b) placing an ablation probe tip having a center of ablation so that the center of ablation is in the three-dimensional location of the middle of a tooth bud; and (c) at least partially ablating at least one tooth bud.

Described herein is a custom surgical stent for use in a tooth bud ablation procedure that results in tooth agenesis, the custom surgical stent for use with an ablation probe tip having a center of ablation, the stent including: (a) a custom surgical stent with at least one surgical guide corresponding to at least one tooth bud surgical site; (b) the at least one surgical guide having guiding structure to guide placement of an ablation probe tip at a pre-defined angle so that a center of ablation of the ablation probe tip is in the middle of a tooth bud; and (c) the at least one surgical guide having mechanical stop structure to limit the depth of the ablation probe tip to a pre-defined depth.

The foregoing and other objectives, features, and advantages of the invention will be more readily understood upon consideration of the following detailed description of the invention, taken in conjunction with the accompanying drawings.

BRIEF DESCRIPTION OF THE DRAWINGS

The accompanying drawings are incorporated in and constitute a part of this specification.

FIG. 1 is an X-ray showing a 48-year-old patient with both upper third molars present, the X-ray being presented to show examples of the range of problems that adult patients experience when they have third molars that are not extracted at an early age.

FIG. 2 is an X-ray showing a 36-year-old patient with all four third molars present, the X-ray being presented to show examples of the range of problems that adult patients experience when they have third molars that are not extracted at an early age.

FIG. 3 is an X-ray showing a 9-year-old patient with four third molar tooth buds present; three of them are in very early stages of enamel formation, but the lower right third molar tooth bud does not yet have enamel formed.

FIG. 4 is a flow chart showing steps in preferred TBA procedures including: (1) routine screening and diagnosis; (2) pre-surgical impressions and scanning; (3) assembling a TBA surgical kit; (4) operator delivery of the TBA procedure; and (5) follow-up.

FIG. 5 is a simplified block diagram of a TBA probe system, a custom surgical stent, and a tooth bud.

FIG. 6 is a cross-sectional side view of an ablation probe tip in the process of being inserted through a surgical guide of a stent.

FIG. 7 is a cross-sectional side view of an ablation probe tip inserted through a surgical guide of a stent into the tooth bud.

FIG. 8 is a cross-sectional side view of an ablation probe tip having a linear array of temperature sensors inserted in the tooth bud.

FIG. 9 is a cross-sectional side view of an ablation probe tip ablating the tooth bud.

FIG. 10 is a cross-sectional side view of an ablation probe tip being removed from the ablated tooth bud.

FIG. 11 is a flow chart showing the steps of a TBA procedure that result in tooth agenesis.

FIG. 12 is a flowchart showing the steps that a software program for manufacturing or fabricating custom surgical stents 110 and defining (and/or computing or calculating) the pre-determined parameter settings and/or treatment time settings.

FIG. 13 is a panoramic X-ray showing a patient whose third molar tooth buds in the #17 and #32 positions are treatable by TBA.

FIG. 14 is a pre-operative cone beam computed tomography (“CBCT”) scan of a different patient.

FIG. 15 is a series of X-rays showing successive 1.0 mm slices through both #17 and #32 in 1.0 mm increments.

FIG. 16 is a perspective view from a front corner showing a pre-operative upper-arch impression being taken of a simulated patient.

FIG. 17 is a cross-sectional view of an upper-arch impression being taken of a simulated patient.

FIG. 18 is a perspective view from above of the completed upper-arch impression.

FIG. 19 is a perspective view from above of the completed upper-arch impression, along with a stone model that will serve as a “positive” for manufacturing or fabricating of a custom surgical stent for that patient’s upper-arch.

FIG. 20 is a CBCT scan with notations showing the measurement of the angle of entry into the tooth bud.

FIG. 21 is a series of X-rays with notations showing the measurement of the lateral angle of entry.

FIG. 22 is a CBCT scan with highlights showing the computed volume of each tooth bud.

FIG. 23 is a perspective view from above of a surgical stent with two surgical guides, the stent having been manufactured or fabricated using the CBCT positioning information.

FIG. 24 is a perspective view showing topical anesthetic being applied to the base of the surgical guide.

FIG. 25 is perspective view from a front corner of a surgical stent being seated on the upper-arch of the simulated patient.

FIG. 26 is a perspective view from a front corner of a local anesthetic being injected into a tooth bud site.

FIG. 27 is a perspective view from a front corner of a tissue trocar being used to punch to the base of a tooth bud.

FIG. 28 is a perspective view from a front corner of an ablation probe tip with a mechanical (physical) stop being positioned through the surgical guide into the tooth bud.

FIG. 29 is a perspective view from a front corner of the ablation probe tip being positioned in each tooth bud through the surgical guide so that the ablation probe tip’s effective center of ablation is in the middle of each tooth bud.

DETAILED DESCRIPTION OF THE INVENTION

The highly invasive surgical procedure of extracting third molars can be completely eliminated by prophylactically eliminating the small tooth buds that will eventually form the wisdom teeth. Children age 6 to 12 will generally have

radiographically detectable tooth buds with no signs of tooth formation inside the tooth bud. Third molar tooth bud agenesis (the lack of third molar formation) can only be conclusively determined by age 14. Third molar tooth buds are lying just 2.0 mm to 3.0 mm beneath the surface of the attached gingival (gum) tissue, making them accessible for rapid anesthesia and minimally invasive ablation with the correct selection of soft tissue ablation and supporting scanning and stent-manufacturing technologies.

By successfully improving existing medical technology, the highly invasive, painful, and complication-ridden procedure of traditional surgical removal of third molars (i.e. "wisdom teeth" extractions) can be replaced with a minimally invasive tooth bud ablation (TBA) procedure **70** such as that shown in FIG. **4** that is risk free, painless post-operatively, and less expensive when compared to surgical extractions.

The TBA procedure **70** (FIG. **4**) and TBA system **100** (FIG. **5**) for use in the TBA procedure **70** seek to achieve: (1) a minimally invasive procedure consisting of a surgical access path at a surgical site (e.g. at each tooth bud surgical site), (2) that can predictably ablate all four third molar tooth buds **120** in thirty (30) minutes or less (including time to administer anesthesia) using either microwave ("MW") or radio frequency ("RF") ablation, (3) that can be administered by dental practitioners under normal office conditions, (4) with direct procedure costs reduced by 25% or more, and (5) with zero risks or complications when compared to traditional surgical extraction of fully developed third molars. It should be noted that the TBA procedure **70** is shown and described as a prophylactic third molar tooth bud ablation (TMTBA), but it is not limited thereto. For example, there may be supernumerary teeth that should not be in a patient's mouth (e.g. there may be two teeth #5), the removal of which would not be prophylactic in nature.

One preferred advantage of the surgical phase **90** described herein is that it is a minimally invasive surgical procedure. With a minimally invasive surgical procedure design coupled with electronic feedback controls using MW and RF ablation technology to limit soft tissue damage, performing this procedure on children aged 6-12 years old takes approximately thirty (30) (or fewer) minutes, including the time to administer local anesthetics.

Another preferred advantage of the surgical phase **90** described herein is that it will not accidentally disrupt adjacent second molar tooth development, even though the formation of second molars are well under way because these tooth buds **120** have started to form before birth. The use of relatively new scanning technologies (e.g. computed tomography volume scanning such as cone beam computed tomography (CBCT) scanning and MRI volume scanning) and accurate custom surgical stents **110** to guide ablation probe tip **108** placement will eliminate the risk of accidentally disrupting the second molars by minimizing collateral tissue damage.

Summarily, the TBA procedure **70** (FIG. **4**) preferably includes a screening phase **72**, a pre-surgical phase **80** (also referred to as TBA pre-surgical phase **80**) that includes pre-surgical scanning **82** and the assembling of a TBA surgical kit **88** (that includes pre-determined settings **105** as well as a surgical stent **110**), a surgical phase **90** (also referred to as TBA surgical phase **90**), and a follow-up phase **98**.

A TBA system **100** (FIG. **5**) is preferably used during the surgical phase **90** (shown graphically in FIGS. **6-10** and as a flow chart in FIG. **11**) of the TBA procedure **70**. Summarily, the TBA system **100** includes a TBA probe system **101**

(including a generator **104** capable of emitting one or more types of ablation means **104'**, a hand piece **106**, and an ablation probe tip **108**) and at least one surgical stent **110** (which was manufactured or fabricated during the pre-surgical phase **80**). Each stent **110** has at least one surgical guide **112** to guide the placement of the ablation probe tip **108** so that its center of ablation **130a** is placed into the middle of the tooth bud **130b**. This is accomplished by positioning ablation probe tip **108** through the surgical guide **112** at a pre-defined angle and depth using a mechanical relationship of the ablation probe tip **108** and the surgical guide **112** to form a "stop" therebetween. FIGS. **6-10** show (and FIG. **11** describes) the procedure of inserting the ablation probe tip **108** through the surgical guide **112** of a stent **110**, ablating the tooth bud **120**, and removing the ablation probe tip **108** from the ablated tooth bud **120'**.

The TBA System **100**

The TBA system **100** described herein is the system that is used during the surgical phase **90** of the TBA procedure **70**. Some of the components (e.g. the custom surgical stent **110** and the pre-determined settings **105**) used in the TBA system **100** are part of the TBA surgical kit assembled during the pre-surgical phase **80**.

The TBA system **100**, as shown in FIG. **5**, includes a TBA probe system **101** (including a generator **104**, a hand piece **106**, and an ablation probe tip **108**) and at least one surgical stent **110** (each stent **110** has at least one surgical guide **112** to guide (direct) the placement of the ablation probe tip **108** to the middle of the tooth bud **130b**). The generator **104** and the hand piece **106** may be jointly referred to as the ablation probe unit **102** (or the programmable ablation probe unit **102**). The generator **104** and hand piece **106** may be integral or functionally connected together. The generator **104** (and/or the ablation probe unit **102**) may be programmed with pre-determined parameter settings **105a** and/or treatment time settings **105b** (referred to jointly as pre-determined settings **105**). The generator **104** (and/or the ablation probe unit **102**) provides an ablation means **104'** for ablating the tooth bud **120** based on the pre-determined settings **105**. Central to the TBA system **100**, is the interaction between the ablation probe tip **108** and the surgical stents **110** (and specifically the surgical guides **112**).

Generator **104**

The generator **104** provides the ablation means **104'** suitable for ablating a tooth bud **120** during the surgical phase **90** of the TBA procedure **70**. MW energy and RF energy are discussed as exemplary preferred ablation means **104'**. Another alternative preferred ablation means **104'** is irreversible electroporation because it has subsecond activation times that can reduce collateral tissue damage. Yet another alternative preferred ablation means **104'** include, but are not limited to, cryoablation, ultra-high intensity ultrasound, laser, chemical, thermal or hot tip (e.g. a tip having any source of heat including, but not limited to a light bulb, a soldering iron, or steam heat), and/or mechanical means. These ablation means **104'** may also be combined either simultaneously or consecutively. It should also be noted that other known and yet-to-be-developed ablation means **104'** may also be used. It should be noted that although discussed primarily in terms of MW and RF, unless specifically set forth otherwise, the use of other ablation means **104'** is possible.

The generator **104** (alone or as part of an ablation probe unit **102**) may be programmed by the operator and/or at the laboratory and/or factory and may be accomplished auto-

11

matically or manually. The programming of the generator **104** may include programming at least one pre-determined setting **105**.

The following bulleted points are exemplary details and/or features that may be incorporated in preferred generators **104**.

Preferred generators **104** may be multi-use devices designed as 110V counter-top units.

Preferred generators **104** may be MW/RF generators with output levels determined initially through finite element analysis models or experimentally derived functions that exist for tumor ablation.

Preferred generators **104** (and/or ablation probe units **102**) may have operator input mechanisms (e.g. knobs, dials, key pads, keyboards, I/O interfaces, connections to the internet, or other means for inputting or programming) in which the operator inputs (or allows input of) the pre-determined settings **105**.

Preferred generators **104** (and/or ablation probe units **102**) may have output mechanisms **103** (e.g. a display or audio) for providing setting feedback (e.g. calibration cycles and pre-determined settings **105**), warning feedback (e.g. to prevent operator mishandling), and intra-operative feedback on the progress of the procedure such as time remaining (e.g. a count down or a series of beeps to alert the operator to procedure completion) and/or temperature (e.g. to alert the operator to overheating).

Preferred output displays may be digital readout displays (that may be color and/or in a large format) that permit the operator to easily see feedback intra-operatively from across a standard dental operatory (approximately 6-8 feet viewing distance).

Hand Piece **106**

The hand piece **106** is the functional intermediary between the generator **104** and the ablation probe tip **108**. The hand piece **106** may be connected substantially at one end to the generator **104**. Substantially at the end of the hand piece **106** opposite the generator **104**, the other end of the hand piece **106** (the surgical end) is adapted to accept the ablation probe tips **108**. The hand piece **106** is preferably detachable from the generator **104** (if they are not an integral unit) and the ablation probe tip **108** is preferably detachable from the hand piece **106**.

The following bulleted points are exemplary details and/or features that may be incorporated in preferred hand pieces **106**.

Preferred hand pieces **106** preferably hold or secure an ablation probe tip **108** by latching the ablation probe tip **108** into the hand piece head. In some hand pieces **106**, the ablation probe tip **108** latches into the hand piece head at an angle (e.g. a 90 degree angle). It should be noted that the terms "latching" and "latch" are used to describe any type of secure fit including, but not limited to, clipping, snapping, or holding.

Preferred hand pieces **106** preferably have a hand piece head (attached or integral) that is at an approximately 20 degree angle to the rest of the hand piece. This bend emulates a standard dental high-speed hand piece to facilitate easy access of both upper and lower surgical sites. In some preferred hand pieces **106**, the 20 degree bend can be adjusted intra-operatively to permit improved operator access to both upper and lower arches.

Preferred hand pieces **106** preferably are rapidly detachable from the generator **104**. Preferably the connectors are ultra-reliable for repeated removal/attachment from the generator **104**.

12

Preferred hand pieces **106** are preferably fully steam autoclavable. Alternative preferred hand pieces **106** are disposable or have disposable covers.

Preferred hand pieces **106** preferably have actuators to allow operator activation. The actuators may be separate from the hand pieces **106** or integral therewith. Exemplary actuators include, but are not limited to a wireless foot control or a hand-operated switch on the hand piece **106**.

The hand piece **106** may be integral with the generator **104** to form a hand-held integrated generator unit (hand-held integrated ablation probe unit).

Ablation Probe Tip **108**

One end of the ablation probe tip **108** has structure suitable for connecting it to the hand piece **106**. The ablation means **104'** flows from the generator **104** through the ablation probe tip **108** and out to a center of ablation **130a** (the focal point of the ablation). The ablation probe tip **108** is insertable through the surgical guide **112**, through the gingival tissue **122**, and into the middle of the tooth bud **130b**. The center of ablation **130a** is at the insertion end of the ablation probe tip **108** such that when the insertion end of the ablation probe tip **108** is positioned at the pre-defined angle (ϕ) and pre-defined depth (x) during the surgical phase **80**, the center of ablation **130a** substantially coincides with or overlaps the middle of the tooth bud **130b**.

The pre-defined angle (ϕ) is the angle at which the ablation probe tip's effective center of ablation **130a** is in the "middle" of the tooth bud **130b** as calculated (during the pre-surgical phase **80**) as described herein or using an alternative method. The pre-defined depth (x) is the depth at which the ablation probe tip's effective center of ablation **130a** is in the "middle" of the tooth bud **130b** as calculated as described herein or using an alternative method. The phrase "middle of the tooth bud **130b**" is meant to include the three-dimensional area within the tooth bud **120** and, in particular, the three-dimensional area within the tooth bud **120** that is more towards the absolute middle point than towards the outer periphery of the tooth. The pre-defined angle (ϕ) and pre-defined depth (x) can also be referred to as the "calculated angle and depth," the "prescribed angle and depth," the "proper angle and depth," the "correct angle and depth," the "optimal angle and depth," or the "ideal angle and depth."

The ablation probe tip **108** includes a mechanical stop structure **140** (e.g. a band, protrusion, or shoulder) designed to physically limit the depth of the ablation probe tip **108** when used in conjunction with mechanical stop structure **142** (e.g. the upper surface, a protrusion on the upper surface, or a notch in the upper surface) of the surgical stent **110** and/or surgical guide **112**. In other words, the mechanical stop structure **142** of the surgical guide **112** and the mechanical stop structure **140** of the ablation probe tip **108** together limit how much of the ablation probe tip **108** can pass through the surgical guide **112** until there is a mechanical stop between the mechanical stop structure **142** of the surgical guide **112** and the mechanical stop structure **140** of the ablation probe tip **108**.

Each ablation probe tip **108** may be individually custom made (e.g. manufactured or fabricated) or may be selected from a family of ablation probe tips **108** (i.e. there may be a "family" of probe tips **108** that will cover all clinical possibilities for tooth bud diameters and depths). In the manufacturing or fabricating of the surgical stents **110**, however, the characteristics of the ablation probe tip **108** (custom made or selected) that may be taken into consideration include, for example, length, shape, angle, position of

a mechanical stop structure **140**, diameter, and size, shape, and location of the center of ablation **130a**. For example, if a particular ablation probe tip **108** had mechanical stop structure **140** (shown as the bottom surface of an annular ring or shoulder in FIGS. 6-10 and 28-29) is 10.0 mm from the absolute tip of the ablation probe tip **108** (and the center of ablation **130a** is substantially adjacent to the absolute tip), but the center of ablation **130a** was only 8.0 mm from the surface of the gingival tissue **122** (shown as (x) in FIG. 6), then the surgical guide **112** would have to be 2.0 mm thick (shown as (y) in FIG. 6). On the other hand, if all surgical guides **112** being made by the procedure were exactly 0.5 mm thick, the ablation probe tip **108** would either have to be made or selected so that the mechanical stop structure **140** is 2.5 mm from the center of ablation **130a** of the ablation probe tip **108**. The appropriate ablation probe tip **108** preferably will result in the intra-operative placement of the effective center of ablation **130a** of the ablation probe tip **108** into the targeted middle of the tooth bud **130b** ± 0.5 mm.

The ablation probe tips **108** may be sharp enough and/or may be strong enough so that the ablation probe tips **108** can be “self-introducing” in that the ablation probe tips **108** can be pushed through the gingival tissue **122**. Alternatively, if tissue trocars **146** (described herein) are to be used, the ablation probe tips **108** would not have to be as sharp and/or strong.

The following bulleted points are exemplary details and/or features that may be incorporated in preferred ablation probe tips **108**.

- Preferred ablation probe tips **108** are preferably disposable (e.g. single-use).

- Preferred ablation probe tips **108** may be specially designed to work with the specific ablation means **104'** produced by the generator **104**. Other preferred ablation probe tips **108** may be designed to work with multiple types of ablation means **104'** produced by the generator **104** or generators **104**.

- The design of the ablation probe tip **108** may be dependent on the physics involved with transmitting ablation means **104'** through the smallest possible diameter with an ideal maximum diameter. For example, an MW/RF ablation probe tip may be designed for transmitting MW/RF energy through the smallest possible diameter with an ideal maximum diameter of 0.5 mm to 1.0 mm targeted.

- The “family” of probe tips **108** may include probe tips **108** having a variety of characteristics. For example, the family might have probe tips **108** of different lengths ranging from 5.0 mm to 20.0 mm. This range would accommodate the various diameters of the tooth buds **120** and overlying gingival tissue **122** thicknesses.

Intra-operative temperature sensing (shown as being performed by a linear array of temperature sensors **144** in FIG. 8) is preferably provided at or near the apex of the ablation probe tip **108** (assuming placement in the ideal middle of the tooth bud **130b**) and/or along the shaft **145** of the probe tip **108**. Temperature sensors **144** provide core temperatures for feedback control purposes (so that the operator can monitor the temperature and/or for software feedback control loops and emergency shutdown) and/or for safety controls to reduce or eliminate collateral tissue damage. Intra-operative tissue temperature is preferably measured, both to assure complete ablation and to prevent over-heating of tissues; this may require additional set up data or programming. If temperature sensors **144** are used, the appropriate ablation probe tip **108** preferably will result in the intra-operative

placement of the effective center of ablation **130a** of the ablation probe tip **108** into the targeted middle of the tooth bud **130b** ± 1.0 mm.

Stent **110**

The at least one custom surgical stent **110** (also referred to as a “stent **110**” or a “surgical stent **110**”) has at least one surgical guide **112** (also referred to as “guides **112**” or “ablation probe tip guides **112**”). Two surgical stents **110** would be used, for example, if both upper and lower tooth buds **120** were to be ablated. The surgical stents **110** are designed to seat in a patient’s mouth and may be supported by at least one tooth (a tooth-supported surgical stent), soft tissue (a soft tissue-supported surgical stent), and/or bone (a bone-supported surgical stent). If the surgical stent **110** is supported by more than one of these, it could be considered a combination-supported surgical stent. Preferred surgical stents **110** may “snap” into the mechanical undercuts inherent in the patient’s erupted teeth. A surgical stent **110** would have more than one surgical guide **112** if more than one tooth bud were to be ablated on either the upper or lower jaw.

The surgical stents **110** and the guides **112** therein are used to control both the pre-defined angle (ϕ) and the pre-defined depth (x) of the ablation probe tip **108** in order to assure that the ablation probe tip’s effective center of ablation **130a** is in the middle of the tooth bud **130b** ± 0.5 mm. The pre-defined angle (ϕ) is primarily controlled by the angle of the surgical guides **112** (the passageways through the stent **110**). The pre-defined depth (x) is primarily controlled by the interaction between the mechanical stop structure **142** of the surgical stent **110** (and/or surgical guide **112**) and the mechanical stop structure **140** of the ablation probe tip **108**. The operator inserts the ablation probe tip **108** at the entry angle (ϕ) defined by the guide **112** and to the depth (x) limited by the mechanical stop structure **140**, **142**.

The surgical guides **112** are passageways through the surgical stent (the passageways being a type of guiding structure). The pre-defined angle (θ) for each passageway (guide **112**) is determined by the position of the middle of the tooth bud **130b**. For example, if the middle of the tooth bud **130b** is “slightly forward” the angle (θ) of the passageway (guides **112**) would be “slightly forward” so that the ablation probe tip **108** is angled “slightly forward” so that the center of ablation **130a** is positioned substantially at the middle of the tooth bud **130b**. The angle (θ) of the passageway is determined (e.g. calculated) by the software based upon tooth bud volumes determined in pre-surgical volume scanning **82**. In addition to providing a path through which the ablation probe tip **108** accesses the gingival tissue and the tooth bud, the guides **112** may also be used to provide access for administering local anesthetic and to provide access to a tissue trocar **146** (if necessary).

In the shown preferred example, the mechanical stop structure **142** is the upper surface of the surgical stent **110** and/or surgical guide **112**. The mechanical stop structure **142** is substantially adjacent to or near the surgical guide **112**. The mechanical stop structure **142**, however, could be positioned at locations of the surgical stent **110** beyond the surgical guide **112**. Alternative preferred mechanical stop structure **142** includes a protrusion on the upper surface or a notch in the upper surface. The size and shape of the mechanical stop structure **142** is determined (calculated or designed) by a process that may be implemented as software or as a program and is based upon tooth bud volumes determined in pre-surgical volume scanning **82** as well as the length between the ablation probe tip mechanical stop structure **140** and its center of ablation **130a**. For example,

if the middle of the tooth bud **130b** is 2.5 mm below the surface (determined in pre-surgical volume scanning **82**), and the available ablation probe tips **108** have a length (between their respective mechanical stop structure **140** and its center of ablation **130a**) of 2.4 mm and 2.6 mm, the process (that may be implemented by software or a program) would determine that the 2.6 mm ablation probe tip **108** is the appropriate ablation probe tip **108** (the 2.4 mm ablation probe tip **108** being too short), but that the surgical stent **110** and/or surgical guide **112** would have to be approximately 0.1 mm thick to make up the difference or the 2.6 mm ablation probe tip **108** would be able to be pushed in too far.

FIG. **12** is a flowchart showing the steps of a process (that may be implemented as one or more software program or subprograms if the shown steps are divided) that, in part, determines the pre-defined angle (ϕ) and the pre-defined depth (x) (see steps **200**, **210**, **212**, **214**, **216**, and **218**). Using this process, patient volume scans are used to accurately manufacture or fabricate custom surgical stents **110** with the correct ablation probe tip angle (ϕ) and depth (x) manufactured into them. More specifically, using this process with the volume scans will permit accurate placement of the distal surgical guides **112** onto the custom surgical stents **110** so that both angle (ϕ) of insertion and depth (x) of insertion of the ablation probe tip **108** are controlled to ± 0.5 mm, placing the ablation probe tip's effective center of ablation **130a** in the middle of the tooth bud **130b**.

The following bulleted points are exemplary details and/or features that may be incorporated in preferred stents **110**.

Preferred surgical stents **110** are preferably disposable (e.g. single-use).

Manufacturing or fabricating of the custom surgical stents **110** may be based upon Poly Vinyl Siloxane (PVS) full arch impressions of the patient's erupted teeth using either conventional lab fabrication techniques or direct-digital manufacturing or fabricating techniques. If an operator has a CBCT unit in his office, it may be possible to directly scan the PVS impressions and email the volume scan of the impression to eliminate the need to physically send them to the lab. The impression materials may include materials other than PVS and preferably will be contrast-optimized through the addition of X-ray contrast agents (such as barium or iodine) to provide optimized volume scans of the dental impression for resolving the fine surface detail of the teeth and gingival tissue **122**. This unique material would be a radiographic contrast-optimized dental impression material for high resolution X-ray CT volume scanning.

Preferred surgical stents **110** are preferably made of any appropriate material including, but not limited to plastic, acrylic, or other nontoxic sturdy material suitable for use in a patient's mouth. One exemplary surgical stent **110** composition may be, for example, clear acrylic (polymethyl methacrylate). It should be noted that materials suitable for additive-type manufacturing (or other direct-digital manufacturing or fabricating techniques) that resulted in nontoxic sturdy stents would be preferable.

Preferred surgical stents **110** preferably have markings such as color codes or numbering clearly marking or identifying the tooth bud numbering sites.

Once the surgical stent **110** is seated onto the patient's teeth, it preferably will remain firmly in place throughout the surgical phase **90** of the TBA procedure **70**.

The operator may administer local anesthetic through the guides **112**.

Pre-Determined Settings **105**

The pre-determined settings **105** include, for example, pre-determined parameter settings **105a** and/or treatment time settings **105b** that are needed to control (provide instructions to) the generator **104** (alone or as part of an ablation probe unit **102**) to provide sufficient ablation means **104'** to ablate the tooth bud **120**, but not so much as to incur significant collateral soft tissue damage (e.g. to the gingival tissue **122**). For example, the pre-determined parameter settings **105a** might control the quantity and quality ablation means **104'** delivered to the tooth bud **120**. The actual pre-determined parameter settings **105a** will be highly dependent on the type of ablation means **104'** to be delivered. For example, MW and RF ablation means might have parameters relating to wavelength and/or frequency, hot tip ablation means might have parameters relating to temperature, chemical ablation means might have parameters relating to the strength of the chemical and how fast the chemical is flowing into the tooth bud, and mechanical ablation means might have parameters relating to speed.

The pre-determined settings **105** are determined (which includes computing, calculating, looking up, processing, or otherwise determining) by a process (that may be implemented as software or a program) based upon tooth bud volumes determined in pre-surgical volume scanning **82**. It should be noted that the pre-determined settings **105** may take into consideration factors other than tooth bud volume including, but not limited to, image recognition programs to measure tooth bud location, age and size of the patient, and other relevant factors to successfully image the patient for the TBA procedure **70**. FIG. **12** is a flowchart showing the steps of a process (that may be implemented as one or more software program or subprograms if the shown steps are divided) that, in part, determines the pre-determined parameter settings **105a** and/or treatment time settings **105b** (see steps **200**, **220**, **222**, and **224**).

The generator **104** (and/or the ablation probe unit **102**) may be programmed by the operator and/or technicians at the laboratory and/or factory. The programming may be automatic or manual. "Programming" includes having the pre-determined settings **105** pre-entered and/or entering (inputting) the pre-determined settings **105** manually or automatically into the generator **104** (and/or the ablation probe unit **102**) via operator input mechanisms. For example, the pre-determined settings **105** may be preprogrammed into an ablation probe unit **102**, transmitted to the operator in the form of a programming signal (e.g. over the internet to be downloaded and installed in the ablation probe unit **102** or the generator **104**), provided in the form of computer-readable media (e.g. a disc or a solid state USB drive), and/or provided as data (or a code) that may be manually entered into the ablation probe unit **102** (or the generator **104**). Ideally, whichever method of entering/programming the ablation probe unit **102** (or the generator **104**) is used, operator error is considered and eliminated as much as possible and appropriate checks are used. Preprogramming and some of the other means for programming the ablation probe unit **102** (or the generator **104**) with the pre-determined settings would help to eliminate operator input errors. Another example of means for eliminating errors is that even if the ablation probe unit **102** (or the generator **104**) is preprogrammed by the laboratory, the pre-determined settings might be displayed to the user for independent "verification" as the user could notice variations from normal pre-determined settings (e.g. the literature

provided might provide a range and the operator would notice if the provided pre-determined settings **105** fell outside of the range). Yet another example is that the pre-determined settings might be provided as a code that, when input, would only function if it corresponded with a logical setting (e.g. if the person's age was also input into the ablation probe unit **102** and the code was not a logical setting based on the age, the ablation probe unit **102** would not function).

The pre-determined settings **105** for each TBA site may be included in the TBA surgical kit as a print out, on a disk or other computer readable storage media, or with instructions on how to obtain or download the information.

The pre-determined ablation means parameter settings **105a** can also be referred to as "parameter settings **105a**," "preferred parameter settings **105a**," "optimal parameter settings **105a**," "ideal parameter settings **105a**," "pre-determined parameter settings **105a**," "recommended parameter settings **105a**," or "prescribed parameter settings **105a**."

Tissue Trocar **146**

If the ablation probe tip **108** is not self-introducing, at least one sharp instrument (that is preferably disposable) such as a tissue trocar **146** (and sometimes a plurality of tissue trocars) may be used by the operator to introduce (initially create) the access opening through the thick attached gingival tissue **122** that overlays third molar tooth buds **120**. The tissue trocar tips are preferably sharp enough to be pushed and/or punched through the gingival tissue **122** into the base of the tooth bud. The diameter of the tissue trocar **146** rapidly increases up to 100% of the size of the ablation probe tip **108**. After the tissue trocar **146** has created the access opening, the tissue trocar **146** is removed and the ablation probe tip **108** is immediately placed into the access opening.

TBA Surgical Kit

The TBA surgical kit is a package that includes the majority of the necessary components and information for the surgical phase **90** of the TBA procedure **70**. The TBA kit will be assembled (or the assembly will be completed) based on the patient's impressions and volume scans. Preferably the TBA surgical kit has attractive packaging.

An exemplary TBA surgical kit may consist of (a) a custom surgical stent **110** for each arch as required, (b) at least one ablation probe tip **108** labeled its respective surgical site, (c) at least one tissue trocar **146** (if necessary), and (d) pre-determined settings **105** for each TBA site along with patient and operator identification.

If feedback controls are a part of the ablation probe tip design, then the correct in situ tissue temperature settings are preferably computed and supplied with the ablation probe tips **108** as part of the surgical kit.

The generator **104** and/or the hand pieces **106** are standard equipment in a dental office and/or can be purchased separately.

The ablation probe tips **108** may be pre-purchased (or extras may be kept in a practitioner's office) in which case the TBA surgical kit would provide a part number or other identifying information so that the practitioner would know which ablation probe tip **108** should be used with each guide **112**.

It should be noted some of the components may not be part of the physical TBA surgical kit. For example the pre-determined settings **105** may be provided electronically.

The TBA Procedure **70**

Using the TBA procedure **70** described herein, the effective center of ablation **130a** of the ablation probe tip **108** can be positioned at a pre-defined angle (ϕ) and pre-defined depth (x) so that the ablation probe tip's effective center of ablation **130a** is positioned substantially in the "middle" of the tooth bud **130b** within approximately 50%, 25%, or even less than 10% of the average diameter of the tooth bud **120**. This is extremely accurate as compared to previous procedures.

FIG. **4** shows the steps and/or phases in an exemplary preferred TBA procedure **70**: (1) routine screening and diagnosis **72**; (2) pre-surgical scanning **82** (including taking impressions **84** and using scanning technology **86**); (3) assembling a TBA surgical kit **88** (including pre-determined settings **105** and a stent **110**); (4) operator delivery of the surgical phase **90** of the TBA procedure **70** (shown in more detail in FIG. **11**); and (5) post-surgical steps **98**. Steps (2) and (3) are also referred to jointly as the pre-surgical phase **80** during which steps are taken to create (including calculating, manufacturing, fabricating, selecting, and/or assembling) components of the TBA system **100** and/or the TBA surgical kit to be provided to the operator. Step (4) is also referred to as the surgical phase **90** of the TBA procedure **70** during which the steps shown in FIG. **11** are taken to ablate tooth buds **120**.

(1) Screening Phase **72**

Routine screening using panoramic or intra-oral X-ray imaging techniques is necessary to identify the presence of forming tooth buds **120** starting at age 6 through age 12 because of the wide range of ages involved with the formation of third molar tooth buds **120**.

(2) Impressions and Scanning of Pre-Surgical Phase **80**

Once third molar tooth buds **120** have been identified to be present using standard screening methods (screening phase **72**), the next step is to pre-operatively measure the precise three-dimensional location and volume of each third molar tooth bud **120**. This may be practically accomplished using scanning technology **86** (e.g. computed tomography volume scanning such as CBCT). Scanning technology **86** can be used to accurately generate the necessary three-dimensional volume scans (computed tomography volume scans) and measurements ± 0.2 mm using, for example, the distal side of erupted first molars as durable physical landmarks (although it is possible to use soft tissue over bone as landmarks). The scanning technology **86** produces tooth bud size and position data **86'** (also referred to as "volume scans" and/or "measurements") that is provided for the step of producing the TBA surgical kit **88**. The tooth bud size and position data **86'** may be provided as a scanning technology file that can be any data file generated by the scanning technology **86** with the data necessary to manufacture or fabricate a stent **110**. One exemplary type of scanning technology file is a three-dimensional computer aided design (CAD) file.

An impression **84** of the patient's teeth and gum tissue (gingival tissue **122**) is made using standard impression materials such as PVS-type impression material (although other impression materials can be used). The impressions **84** are then processed and/or scanned using scanning technology (e.g. CBCT imaging by dentists and/or CT imaging in the laboratory), and the resulting volume scan of the impression is emailed (or otherwise transmitted or delivered) to a laboratory and/or factory where the volume scan is used for manufacturing or fabricating. It is still possible to physically mail the PVS dental impressions **84** to the designated laboratory and/or factory for manufacturing or fabricating.

Although the scanning technology is discussed primarily in terms of computed tomography volume scanning (e.g. CBCT technology), alternative scanning technologies including, but not limited to, ultrasound scanning technologies and future developed scanning technologies are included in the scope of the invention. Specialty software or programs may be used with the scanning technology **86** to accomplish the purpose described herein. It should be noted that alternative scanning technology **86** (including future developed scanning technology) may be used if it is able to accurately generate the necessary three-dimensional volume scans and measurements ± 0.2 mm using the distal side of erupted first molars (or other landmarks) as durable physical landmarks. It should be noted that alternative scanning technology (including future developed scanning technology) may also be used as long as two- or three-dimensional scanning results in the positioning of the effective center of ablation **130a** within approximately 50%, 25%, or even less than 10% of the average diameter of the tooth bud **120**.

(3) Assembling a TBA Surgical Kit **88**

The pre-surgical phase **80** of the TBA procedure **70** includes assembling a TBA surgical kit **88**. This step of assembling a TBA surgical kit **88** preferably includes computing pre-determined settings **105** and manufacturing or fabricating the stent **110** based on tooth bud size and position data **86'** obtained from the scanning technology **86**. The process of computing pre-determined settings **105** may be controlled by a process (that may be implemented by software or a program). The process of manufacturing or fabricating the stent **110** may also be controlled by a process (that may be implemented by software or a program).

After the impressions **84** are processed and/or scanned and the tooth bud size and position data **86'** is obtained, the process of manufacturing or fabricating the stent **110** may be carried out using direct-digital manufacturing or fabricating techniques similar to the processes used for manufacturing or fabricating implant surgical stents directly from CBCT scans (e.g. the processes used for fabricating SurgiGuide™ and other implant surgical guides) and the process used for manufacturing or fabricating orthodontic aligners (e.g. orthodontic aligners made by Align Technology or ClearCorrect). The direct-digital manufacturing or fabricating techniques, however, use the tooth bud size and position data **86'** to position and angle the surgical guides **112** on the distal aspects of the surgical stents **110** and use the erupted first molars as the primary landmark for positioning. Although manufacturing or fabricating will usually be done remotely in a laboratory and/or factory, it is possible that larger clinics will have the ability to manufacture or fabricate surgical stents **110** in their own in-house laboratory and/or factory.

Direct-digital manufacturing or fabricating techniques can be defined as any manufacturing or fabricating process that creates physical parts directly from data (e.g. 3-D CAD files) using manufacturing or fabricating techniques including, but not limited to, surgical stent manufacturing or fabricating technologies, rapid turn-around fabrication technologies, computer aided manufacturing (CAM), technologies using CAD, computer numerical control (CNC) milling, "additive" manufacturing, direct-digital laser stereolithography fabrication, "3-D printing," or any other manufacturing or fabricating means known or yet to be discovered that is capable of using the results generated by scanning to manufacture or fabricate the custom surgical stents. Because of the possibility for the integrated use of direct-digital volume scanning of impressions, low manufacturing costs, and rapid turn around times, use of direct-digital manufacturing or fabricating techniques is one preferred manufac-

turing or fabricating technique, but more traditional manufacturing or fabricating techniques that require more labor intensive manual laboratory processing could also be used.

At least one process that may be implemented as software or as at least one program (e.g. custom software enhancements in the CBCT software) will preferably assist in the direct-digital manufacturing or fabricating of the surgical stents **110** and define (and/or compute or calculate) the pre-determined settings **105**. This process would include defining (and/or computing or calculating) positioning and entry angle data required for placement of the ablation probe tip's effective center of ablation **130a** into the middle of the targeted tooth bud **120**. Additionally, tooth bud volumes are preferably computed (possibly using the scanning technology) and then the tooth bud volumes are used to determine the pre-determined settings **105** necessary to effect therapeutic ablation. Tooth bud volumes will generally range from 4.0 mm to 12.0 mm in diameter at ages 6-12. The ablation means **104'** and treatment times are preferably considered in the calculations. Companies that make CBCT imaging equipment promote the development of procedure-specific software in order to gain end-user acceptance of their imaging systems in the market place. The process may use calculations and/or look-up charts (e.g. based on experimental data) for determining the necessary settings.

FIG. **12** is a flowchart showing the steps of a process (that may be implemented as one or more software programs or subprograms if the shown steps are divided) for manufacturing or fabricating custom surgical stents **110** and/or determining the pre-determined parameter settings **105a** and/or treatment time settings **105b**. As shown, the process begins with receiving pre-operative measurements of the precise three-dimensional location and volume of each third molar tooth bud and information regarding the ablation probe unit including its ablation means capabilities **200**. To make the stents **110**, the process would preferably include the following steps: (a) determining an entry point for an ablation probe tip **210**; computing the angle and depth of the path between the entry point and the middle of a tooth bud **212**; (b) taking into consideration the depth of the path, creating or selecting an ablation probe tip having the proper distance between its mechanical stop and its center of ablation so that the ablation probe tip will be inserted so that its center of ablation will be in the middle of the tooth bud **214**; (c) taking into consideration the angle and depth of the path and the thickness of the surgical stent, computing the surgical guide pathway through which the ablation probe tip will be inserted so that its center of ablation will be in the middle of the tooth bud **216**; and (d) providing the surgical guide pathway as output for the creation of a surgical stent with surgical guides **218**. To calculate the pre-determined parameter settings **105a** and/or treatment time settings **105b**, the process would preferably include the following steps: (a) taking into consideration the information regarding the ablation probe unit including its ablation means capabilities, determining the proper power settings **220**; (b) taking into consideration the information regarding the ablation probe unit including its ablation means capabilities, determining the proper time settings **222**; and (c) providing the proper power and time settings as output for use in programming the ablation probe unit or generator **224**.

As described above, in addition to the surgical stent(s) **110** and the pre-determined settings **105**, the TBA surgical kit may include at least one ablation probe tip **108** labeled for

its respective surgical site, at least one tissue trocar **146** (if necessary), and patient and operator identification.

The TBA surgical kit is provided to the operator.

(4) Surgical Phase **90**

FIGS. **6-10** show graphically, and FIG. **11** shows as a flow chart, the surgical phase **90** of the TBA procedure. The surgical phase **90** may be performed by a dental operator (dental practitioner) in his office (e.g. a pediatric office and/or general dental office) under normal office conditions. At this point, the generator **104** has been programmed with the pre-determined settings **105** and normal surgical procedures have been followed. The generator **104** is preferably tuned so that the ablation means **104'** is set to ablate the small, substantially spherical ablation volumes of third molar tooth buds **120** in order to minimize (or possibly eliminate) collateral osseous and soft tissue damage, especially damage to adjacent second molars that are likely not yet erupted. Further, the surgical phase **90** uses single-use and disposable delivery systems that use components designed for intra-oral use.

Summarily, as shown in FIG. **11**, the first step is physically seating a surgical stent **160** in a patient's mouth. Next, the operator makes an access path at the at least one tooth bud surgical site **162**. The operator also places the ablation probe tip so that the center of ablation is in the middle of a tooth bud at the at least one tooth bud surgical site (using the custom surgical stent to guide the placement) **164**. It should be noted that if the ablation probe tip is "self-introducing," the step of making an access path and the step of placing the ablation probe tip may occur simultaneously. Then, the at least one tooth bud is at least partially ablated **166** and the ablation probe tip is removed from the tooth bud **168**. These and other exemplary steps are detailed in the following paragraphs.

The operator preferably starts the surgical phase **90** by placing the surgical stent **110** into place onto the patient's teeth prior to administering local anesthetic to the surgical site. The local anesthetic will then be administered through the surgical stent **110** and guides **112** that are in close approximation with the gingival tissue **122**, thus reducing the amount of anesthetic necessary because of the precise placement of anesthetic agent. Achieving local anesthesia in this procedure will be easier than anesthetizing lower permanent molar teeth for routine fillings since only soft tissues, which will be 8.0 mm to 15.0 mm deep, are involved.

The step of physically seating a surgical stent **110** may also include physically seating the surgical stent in a patient's mouth, physically seating the surgical stent on a patient's erupted teeth, physically seating the surgical stent on at least one tooth in a patient's mouth, physically seating the surgical stent on a patient's soft tissue, physically seating the surgical stent on a patient's bone, or a combination of the above steps (e.g. physically seating the surgical stent on a patient's teeth, soft tissue, and bone).

Once the custom surgical stent **110** is in place and the patient is fully anesthetized, the operator then mechanically gains access to the tooth bud **120** through the stent surgical guides **112** by creating (introducing) a small surgical access path opening through the gingival tissue **122** approximately 0.1 mm to 2.0 mm (and more particularly 0.5 mm to 1.0 mm) in diameter using tissue trocars. If the ablation probe tips **108** are designed to be strong enough and sharp enough to act as "self-introducing" probe tips, they can be used to introduce the surgical access path. On the other hand, if the ablation probe tip itself is not self-introducing, the surgical

access path may be introduced using a then there will be no need for separate tissue trocar **146**.

It should be noted that the surgical access path is preferably an incision, a puncture, or a hole through the gingival tissue **122**. If a self-introducing probe tip is used, the surgical access path has substantially the same diameter as the ablation probe tip **108**. If the probe tip is not self-introducing, the surgical access path may be a sutureless puncture (0.1 mm to 2.0 mm in diameter) or, more particularly, a sutureless puncture (0.5 mm to 1.0 mm in diameter). Alternatively, a trocar "punch" may be made through tough gingival tissue **122**. Regardless of the procedure used to introduce the surgical access path, using a surgical access path to gain access or allow placement of the ablation probe tips **108** to the tooth bud **120** does not kill, damage, or otherwise cause necrosis to the surrounding soft tissues (e.g. gingival tissues **122**). This can be compared to other processes such as coring, boring, cutting, electrosurge ablating, or other invasive procedures that kill, damage, and/or otherwise cause necrosis to the soft tissue to which the invasive procedure has been applied. Although the preferred procedures for introducing the surgical access path might kill individual cells, the soft tissue (the gingival tissue **122**) does not become necrosed because the tissue is a collection of cells that can heal itself.

As shown in FIGS. **6** and **7**, the next step in the surgical phase **90** is to insert the designated ablation probe tip **108** through the surgical stent **110** and into the tooth bud space until it is mechanically "stopped" in order to position the probe to the prescribed depth (which would be the pre-defined depth). The surgical stent **110** and its surgical guides **112** are used to control the angle (ϕ) and depth (x) of the ablation probe tip **108** so that the effective center of ablation **130a** of the ablation probe tip is in the middle of the tooth bud **130b**. It should be noted that the effective center of ablation **130a** for any given ablation technology does not necessarily correspond with the tip of the ablation probe. For instance, microwave ablation probes have windows or slots that may be 0.5 mm to 2.0 mm from the tip depending on the frequency of the wavelength used. Cryoablation probes have their center of ablation roughly in the middle of the probe, depending on the design and refrigerant used. A mechanical stop structure **140** on the ablation probe tip **108** preferably seats firmly onto the mechanical stop structure **142** of the surgical stent guide **112** to prevent over extension of the ablation probe tip **108**.

FIG. **8** shows embedded temperature sensors **144** (or other types of feedback control mechanisms) that may be used during the ablation process. An independent feedback process using the temperature sensors **144** is preferable for this clinical procedure. Use of temperature sensors **144** along with monitoring probe impedance characteristics and percentage of reflected energy in RF/MW circuits will provide "go/no go" output for the clinician. Control algorithms are preferably used to accelerate initial ablation means **104'** input followed by lower-level temperature maintenance for a defined period of time with independent confirmation that results in a fast process while simultaneously assuring complete tooth bud ablation.

FIG. **9** shows the actual ablation process. Activation of the ablation probe unit **102** to perform the ablation process is executed according to the pre-determined settings **105**. Activation of the ablation probe unit **102** causes the generator **104** to provide the ablation means **104'** that passes through the hand piece **106** and the ablation probe tip **108** and into the tooth bud **120**. This step of at least partially ablating the tooth bud is preferably accomplished without ablating any

surrounding gingival tissue (although a minimal amount of surrounding gingival tissue may be ablated as an accidental byproduct of the step). This can also be thought of as the activation of the ablation probe unit **102** creating a zone of ablation that resides predominately or completely within the tooth bud **120**. The feedback control mechanisms **144** assure successful delivery of adequate ablation means **104'** to ablate the tooth bud **120** while minimizing damage to adjacent osseous and soft tissues by, for example, eliminating over-heating. Given the small tissue volumes involved for pediatric patients, activation using an RF ablation means **104'** would have an ablation time that is preferably less than three (3) minutes and activation using an MW ablation means **104'** would have an ablation time that is preferably less than thirty (30) seconds.

FIG. **10** shows the ablation probe tip **108** being removed from the now ablated tooth bud **120'**. As shown in this figure, any access path created by the procedure rapidly closes.

(5) Post-Surgical Phase **98**:

After the surgical phase **90**, the patient may have follow-up including, but not limited to post-surgical instructions and, if necessary follow-up care and screening.

Post-surgical instructions that may be given to parents includes the following: kids can go out and play immediately unless they were sedated, no post-surgical pain medication is necessary, bleeding (if any) will be gone in minutes, and post-surgical X-ray screening may be necessary at patient's next routine 6-month hygiene cleaning appointment to verify full ablation.

Simulated TBA Procedure **70**

The following paragraphs, along with FIGS. **13-29**, detail an exemplary simulated TBA procedure **70** including routine screening and diagnosis **72**, the pre-surgical phase **80**, and the surgical phase **90**. In several of these figures, a patient's mouth **124** (with gums **122** and teeth **126**) is shown that looks like a stone model, but it should be understood that unless otherwise specified the shown mouth **124** would be a live patient's mouth.

As shown in FIG. **4**, the TBA procedure begins with routine screening and diagnosis **72**. FIG. **13** is a panoramic X-ray showing a patient whose third molar tooth buds **120** in the #17 & #32 positions are treatable by a TBA procedure **70**. FIG. **14** is a pre-operative CBCT scan (although other types of volume scanning could be used) of a patient. In a real procedure, the volume scan would be taken of the specific patient on which the TBA procedure **70** is being performed. This CBCT "reconstructed" panoramic scan has a 1.0 mm scale along its bottom edge. FIG. **15** is a series of CBCT volume scan cross-sections showing successive 1.0 mm slices through both #17 and #32 in 1.0 mm increments. Each X-ray corresponds to 1.0 mm locations along the scale of FIG. **14**. The left-side scale is 1.0 mm vertically. The maximum tooth bud diameters are measured to be 8.0-9.0 mm.

FIG. **16** shows a pre-operative upper-arch impression **84** being taken of the simulated patient's mouth **124** (shown as a stone model for clarity, but an impression **84** would be taken of the patient himself) using an impression tray **128**. It is assumed that all four tooth buds of the wisdom teeth are present in the simulated patient. FIG. **17** is a cross-sectional view of the upper-arch impression **84** being taken of a simulated patient. FIG. **18** shows the completed upper-arch impression **84**. A similar process would be performed to manufacture or fabricate a pre-operative lower-arch impression **84**. At this time the practitioner may send impressions **84** and volume scan data to a laboratory and/or factory for processing.

The laboratory and/or factory uses the impressions **84** and volume scan data (scanning technology file) to create (including calculating, manufacturing, fabricating, selecting, and/or assembling) components of the TBA system **100** (including the surgical stents **110** and the pre-determined settings **105**). The surgical stents **110** and the pre-determined settings **105** and other components are then assembled into the TBA surgical kit to be provided to the operator.

FIG. **19** shows the completed upper-arch impression **84**, along with a stone model **85** that will serve as a "positive" for manufacturing or fabricating a surgical stent **110** for that patient's upper-arch. Alternatively, when using stereolithography manufacturing to manufacture or fabricate surgical stents **110**, the impressions **84** can be computed tomography ("CT") scanned to digitize as an alternative to making physical intermediates. The CT volume scan file (scanning technology file) can then be emailed (or otherwise directly transmitted) for direct manufacturing or fabricating. Alternatively, the practitioner may handle the processing in-house.

FIG. **20** is a CBCT scan with notations showing the measurement of the perpendicular angle of entry into the tooth bud **120**. The measurement is based on the distal aspect of the molar and the occlusal bite plane of the teeth. FIG. **21** is a series of X-rays with notations showing the measurement of the lateral angle of entry. The measurement is determined relative to the vertical axis in order to avoid the jaw's boney interferences during surgical placement of the ablation probe unit **102**. FIG. **22** is a CBCT scan with highlights showing the computed volume of each tooth bud **120**. CBCT volume data is used to determine and/or calculate the pre-determined settings **105**.

FIG. **23** shows the resulting surgical stent **110** that will be placed in a patient's mouth **124**. The shown stent has two surgical guides **112** based upon the location of the patient's two tooth buds to be ablated.

The surgical stent(s) **110** and the pre-determined setting(s) **105** are provided to the operator along with the rest of the TBA surgical kit.

Prior to the surgical phase **90** of the TBA procedure **70**, the ablation probe unit **102** and/or the generator **104** should be set up so that at least one pre-determined setting **105** is correctly entered for at least one tooth bud **120** with safety interlocks carefully considered. (The pre-determined settings **105** may all be entered prior to the surgical phase **90** or they may be entered one at a time.) The surgical phase **90** of the TBA procedure **70** may then be performed.

FIG. **24** shows topical anesthetic **87** being applied to the base of the surgical guide **112** (FIG. **24**) prior to the surgical stents **110** being seated in a patient's mouth **124**.

FIG. **25** shows the surgical stent **110** being seated on the upper-arch of the simulated patient's mouth **124** (shown as a stone model for clarity). This process would be repeated on the lower-arch of the simulated patient.

FIG. **26** shows a local anesthetic being injected **89** into each site through a surgical guide **112** of the stent **110**.

FIG. **27** shows a tissue trocar **146** being used to create an access path through the gingival tissue **122** to the base of each tooth bud **120**. The tissue trocar **146** is only necessary if self-introducing ablation probe tips **108** are not used.

FIG. **28** shows an ablation probe tip **108** with mechanical stop structure **140'** (shown as a shoulder) being inserted through the surgical guide **112**. This would be similar to the position of the ablation probe tip **108** in FIG. **6**.

FIG. **29** shows the ablation probe tip **108** positioned through the surgical guide **112** and into the tooth bud **120** through the surgical guide **112** so that the ablation probe

tip's effective center of ablation **130a** is in the middle of each tooth bud **120**. This would be similar to the position of the ablation probe tip **108** in FIG. 7.

The ablation means **104'** is delivered in this position (FIG. 9). The ablation means **104'** is delivered based on the pre-determined settings **105** (e.g. times, intensities, and other prescribed settings unique to each tooth bud).

The ablation probe tip **108** would then be removed and the process repeated at the site of each tooth bud **120**. Once the entire surgical phase **90** is complete, the surgical stents **110** are removed.

Finally, the dental practitioner or an assistant provides post-surgical instructions to the patient or a caregiver of the patient.

Alternative Scanning and Fabrication of Custom TBA Surgical Kits

An alternative to the pre-surgical phase **80** of the TBA procedure **70** described above includes simultaneous three-dimensional scanning of both hard tissues (bone and teeth) and soft tissues (tooth bud **120** and gingival tissue **122**).

From the information obtained using this unique simultaneous three-dimensional scanning, a custom surgical stent **110** may be manufactured or fabricated. As discussed, the custom surgical stent **110** is used in the surgical phase **90** to help with the placement of the center of ablation **130a** into a tooth bud **120** that results in tooth agenesis.

The simultaneous three-dimensional scanning uses a single scan to obtain both soft tissue and hard tissue information. Soft tissue information generally does not show on a scan, although progress in volume scanning is improving and this may be possible in the near future. Known and future technologies able to provide a scan image of soft tissue are included in the scope of this invention. A typical X-ray scan will only show the hard tissue. So to obtain both soft and hard tissue information using simultaneous three-dimensional scanning, a dental impression **84** is used that can be viewed on an X-ray. The dental impression **84** is made of materials that are preferably "contrast optimized" for high resolution X-ray volume scanning. The ideal level of contrast agent in the range of 25% to 75% radiopacity (such as barium or iodine based compounds) is mixed into the dental impression materials so that the highest level of surface detail can be picked upon when volume scanning the dental impression **84**. The dental impression **84** is placed in the patient's mouth **124** during the X-ray volume scan. The resulting X-ray volume scan image would show the tooth distinguished (is visible) and the dental impression **84** distinguished (is visible) and the void therebetween would be the soft tissue and would therefore be "visible." The resulting X-ray volume scan with both hard and soft tissue information may then be used to formulate the custom stent **110** used in the surgical phase **90** described herein. In other words, an X-ray volume scan image is generated in which hard tissue (e.g. a tooth) is visible hard tissue and the dental impression **84** is a visible dental impression and soft tissue (e.g. gingival tissue **122**) is "visible" as the space between the visible hard tissue and the visible dental impression.

One separate preferred pre-surgical phase **80** of the TBA procedure **70** preferably includes using X-ray volume scans of dental impressions **84** to manufacture or fabricate surgical stents **110**. The X-ray volume scan of the dental impression **84** is "super imposed" over the patient X-ray volume scan (e.g. CBCT scanning) using the dental hard tissues (the teeth) to "snap" the two volume scans together into an accurate overlay so that soft tissues of the mouth (which cannot be X-ray volume scanned directly) are accurately defined for the surgical stent manufacturing or fabricating

(which must take into account the soft tissue and teeth) and probe positioning (which must take into account the tooth bud positioning from the patient's CBCT scan).

One separate preferred pre-surgical phase **80** of the TBA procedure **70** preferably includes using dental impression materials that are "contrast optimized" for high resolution X-ray volume scanning that is then used to manufacture or fabricate surgical stents **110**. The ideal level of contrast agent (such as barium or iodine based compounds) is mixed into the dental impression materials so that the highest level of surface detail can be picked upon when CT volume scanning the dental impression **84**.

Alternative Procedures and Systems

Separate preferred surgical procedures preferably include the ablation of "non-tooth" bud lesions or tumors of the maxilla or mandible. In such a situation, a custom stent would be manufactured or fabricated with guides to guide an ablation probe tip **108** to such a lesion or tumor located at least one lesion or tumor surgical site. The process could then be used to ablate such lesion or tumor.

Separate TBA surgical procedures preferably include the use of ultrasound scanning with combined ultra-high energy ultrasound ablation but without the use of a surgical stent for transgingival tooth bud ablation that results in tooth agenesis. This can be described as direct ultrasound scanning with ultra-high energy ultrasound built into the same scanning head.

Comparison to the Silvestri Study

As set forth in the Background section of this document, the article entitled "Selectively Preventing Development of Third Molars In Rats Using Electrosurgical Energy" by Silvestri et al. describes a pilot study that tests the hypothesis that third molars can be selectively prevented from developing. The results of the Silvestri study were mixed at best, with only ten rats out of thirty-three showing the desired result of no intraoral or radiographic evidence of third molar development. One reason that the Silvestri process was not successful may have had to do with the fact that the Silvestri process was inexact. For example, the Silvestri process relies on molds taken from molds of the mouths of euthanized rat pups rather than using molds fabricated for the rat pup on which the procedure was to be performed. The present invention uses the patient's mouth on which the procedure is to be performed. Another way in which the Silvestri process was inexact was that the Silvestri process did not locate the forming tooth bud **120**. More specifically, the Silvestri process did not locate or determine the location of the forming tooth bud **120** pre-operatively relative to the landmarks that he used. Silvestri even states ". . . when electrosurgical energy is applied near the invisible tooth anlage in the tiny mouth of newborn rats, the effects of the electrosurgical energy cannot be nearly as local or precise. The embryonic tooth-forming tissues of the third molar [lay] fractions of a millimeter below the oral mucosa and cannot be seen. As a result, it was not possible to predictably protect and isolate the vulnerable developing bone from the energy and heat of the electrosurgical energy. The result was a relatively large, unpredictable area of tissue damage during treatment and a wide range of bony developmental effects seen after the rats were euthanized."

The TBA procedure **70** described herein can be distinguished from the Silvestri procedure in several ways including for example, that (1) the TBA procedure **70** described herein is a minimally invasive procedure consisting of introducing a surgical access path at each tooth bud surgical site as opposed to the boring, killing, and damaging procedure described by Silvestri, (2) the TBA procedure **70**

described herein is performed in such a manner that it can be described as exact (e.g. using the patient's mouth as the mold for manufacturing or fabricating the surgical stent **110**, taking exact measurements of the patient's mouth (including the position of the tooth bud **120**), and using calculated parameter and time settings **105b**) as opposed to the Silvestri procedure that can be described as inexact, and (3) the TBA procedure **70** described herein can predictably ablate tooth buds **120** as opposed to the Silvestri procedure that was essentially unpredictable and could never, under any circumstances, be considered for treating human patients.

Flow Charts

FIGS. **4**, **11**, and **12** are flow charts illustrating processes, methods, and/or systems. It will be understood that at least some of the blocks of these flow charts, components of all or some of the blocks of these flow charts, and/or combinations of blocks in these flow charts, may be implemented by software (e.g. coding, software, computer program instructions, software programs, subprograms, or other series of computer-executable or processor-executable instructions), by hardware (e.g. processors, memory), by firmware, and/or a combination of these forms. As an example, in the case of software, computer program instructions (computer-readable program code) may be loaded onto a computer (or on a special purpose machine such as a volume scanner or scanning technology) to produce a machine, such that the instructions that execute on the computer create structures for implementing the functions specified in the flow chart block or blocks. These computer program instructions may also be stored in a memory that can direct a computer to function in a particular manner, such that the instructions stored in the memory produce an article of manufacture including instruction structures that implement the function specified in the flow chart block or blocks. The computer program instructions may also be loaded onto a computer (or on a special purpose machine such as a volume scanner or scanning technology) to cause a series of operational steps to be performed on or by the computer to produce a computer implemented process such that the instructions that execute on the computer provide steps for implementing the functions specified in the flow chart block or blocks. The term "loaded onto a computer" also includes being loaded into the memory of the computer or a memory associated with or accessible by the computer (or on a special purpose machine such as a volume scanner or scanning technology). The term "memory" is defined to include any type of computer (or other technology) —readable media including, but not limited to, attached storage media (e.g. hard disk drives, network disk drives, servers), internal storage media (e.g. RAM, ROM), removable storage media (e.g. CDs, DVDs, flash drives, memory cards, floppy disks), and/or other storage media known or yet to be discovered. The term "computer" is meant to include any type of processor, programmable logic device, or other type of programmable apparatus known or yet to be discovered. Accordingly, blocks of the flow charts support combinations of steps, structures, and/or modules for performing the specified functions. It will also be understood that each block of the flow charts, and combinations of blocks in the flow charts, may be divided and/or joined with other blocks of the flow charts without affecting the scope of the invention. This may result, for example, in computer-readable program code being stored in whole on a single memory, or various components of computer-readable program code being stored on more than one memory.

Additional Information

It is to be understood that the inventions, examples, and embodiments described herein are not limited to particularly exemplified materials, methods, and/or structures. Further, all publications, patents, and patent applications cited herein, whether supra or infra, are hereby incorporated by reference in their entirety.

Please note that the terms and phrases may have additional definitions and/or examples throughout the specification. Where otherwise not specifically defined, words, phrases, and acronyms are given their ordinary meaning in the art. The following paragraphs provide some of the definitions for terms and phrases used herein.

The terms "fabricating" and/or "manufacturing" include any suitable means of making a component (e.g. stent **110**).

Although the terms are used together throughout most of the specification (e.g. "manufacturing or fabricating"), the absence of one term or another is irrelevant because they are used herein synonymously.

The terms "proper," "correct," "optimal," and "ideal," are relative and may become more accurate as technology is developed. For example, when used in terms of the pre-defined angle (ϕ) and pre-defined depth (x) that are calculated and/or prescribed (e.g. the "proper angle and depth," the "correct angle and depth," the "optimal angle and depth," or the "ideal angle and depth"), these phrases are meant to include the best possible angle and depth that is calculated using the best available information and technology.

The terms "provide" and "providing" (and variations thereof) are meant to include standard means of provision including "transmit" and "transmitting," but can also be used for non-traditional provisions as long as the data is "received" (which can also mean obtained). The terms "transmit" and "transmitting" (and variations thereof) are meant to include standard means of transmission, but can also be used for non-traditional transmissions as long as the data is "sent." The terms "receive" and "receiving" (and variations thereof) are meant to include standard means of reception, but can also be used for non-traditional methods of obtaining as long as the data is "obtained."

It should be noted that the terms "may" and "might" are used to indicate alternatives and optional features and only should be construed as a limitation if specifically included in the claims. It should be noted that the various components, features, steps, phases, or embodiments thereof are all "preferred" whether or not it is specifically indicated. Claims not including a specific limitation should not be construed to include that limitation.

It should be noted that, unless otherwise specified, the term "or" is used in its nonexclusive form (e.g. "A or B" includes A, B, A and B, or any combination thereof, but it would not have to include all of these possibilities). It should be noted that, unless otherwise specified, "and/or" is used similarly (e.g. "A and/or B" includes A, B, A and B, or any combination thereof, but it would not have to include all of these possibilities). It should be noted that, unless otherwise specified, the term "includes" means "comprises" (e.g. a device that includes or comprises A and B contains A and B but optionally may contain C or additional components other than A and B). It should be noted that, unless otherwise specified, the singular forms "a," "an," and "the" refer to one or more than one, unless the context clearly dictates otherwise.

The terms and expressions that have been employed in the foregoing specification are used as terms of description and not of limitation, and are not intended to exclude equivalents

of the features shown and described. This application is intended to cover any adaptations or variations of the present invention. It will be appreciated by those of ordinary skill in the art that any arrangement that is calculated to achieve the same purpose may be substituted for the specific embodiment shown. It is also to be understood that the following claims are intended to cover all of the generic and specific features of the invention herein described and all statements of the scope of the invention which, as a matter of language, might be said to fall therebetween.

What is claimed is:

1. A tooth bud ablation probe system for use in a tooth bud ablation procedure that results in tooth agenesis, said tooth bud ablation probe system comprising:

- (a) an ablation probe unit and an ablation probe tip, said ablation probe unit including a generator and a hand piece, said generator being a MW generator for generating MW energy or an RF generator for generating RF energy;
- (b) said ablation probe tip having a shaft, said shaft having an insertion end and an end for connecting said ablation probe tip to the hand piece, said ablation probe tip having a center of ablation at said insertion end;
- (c) a surgical stent having at least one surgical guide, each said surgical guide being a passageway through said surgical stent, each said passageway sized to guide said shaft of said ablation probe tip at a pre-defined angle defined by said at least one surgical guide, said surgical stent being a surgical stent contoured to physically seat in a patient's mouth and be supported by at least one tooth, by soft tissue, or by at least one tooth and soft tissue; and
- (d) said ablation probe tip having mechanical stop structure that physically limits said ablation probe tip to a pre-defined depth in relation to the surgical stent, said mechanical stop structure being a bottom surface of an annular ring or a bottom surface of a shoulder;

wherein when said surgical stent is physically seated so that said at least one surgical guide corresponds to at least one tooth bud surgical site, said ablation probe tip is then guidable at said pre-defined angle and limited to said pre-defined depth so that said center of ablation is within a tooth bud when said ablation probe tip is inserted through at least one surgical guide of the physically seated surgical stent at the pre-defined angle and the pre-defined depth.

2. The tooth bud ablation probe system of claim 1, said shaft of said ablation probe tip being guidable at said pre-defined angle by the at least one surgical guide of the surgical stent, the pre-defined angle being based on information about the position of said tooth bud obtained from a volume scan image.

3. The tooth bud ablation probe system of claim 1, said mechanical stop structure of said ablation probe tip physically limits the depth of said ablation probe tip to the pre-defined depth in relation to the surgical stent, the pre-defined depth being based on information about the position of said tooth bud obtained from a volume scan image.

4. The tooth bud ablation probe system of claim 1, said ablation probe unit being a hand-held integrated ablation probe unit with output mechanisms for providing feedback.

5. The tooth bud ablation probe system of claim 1 further comprising at least one temperature sensor on said ablation probe tip.

6. The tooth bud ablation probe system of claim 1 further comprising at least one temperature sensor provided at or near said insertion end of said ablation probe tip.

7. The tooth bud ablation probe system of claim 1 further comprising at least one temperature sensor provided along said shaft of said ablation probe tip.

8. The tooth bud ablation probe system of claim 1, said ablation probe tip being a self-introducing ablation probe tip for making a surgical access path.

9. The tooth bud ablation probe system of claim 1 wherein said ablation probe tip is guidable by said at least one surgical guide at said pre-defined angle and limited to said pre-defined depth so that said center of ablation is positioned within no more than 50% of an average diameter of the tooth bud from the middle of the tooth bud, as determined using two- or three-dimensional scanning.

10. The tooth bud ablation probe system of claim 1 wherein said ablation probe tip is guidable by said at least one surgical guide at said pre-defined angle and limited to said pre-defined depth so that said center of ablation is positioned within no more than 25% of an average of the tooth bud from the middle of the tooth bud, as determined using two- or three-dimensional scanning.

11. The tooth bud ablation probe system of claim 1 wherein said ablation probe tip is guidable by said at least one surgical guide at said pre-defined angle and limited to said pre-defined depth so that said center of ablation is positioned within no more than 10% of an average diameter of the tooth bud from the middle of the tooth bud, as determined using two- or three-dimensional scanning.

12. The tooth bud ablation probe system of claim 1 wherein said ablation probe tip is guidable by said at least one surgical guide so that said center of ablation is positioned within less than 50% of an average diameter of the tooth bud from the middle of the tooth bud, as determined using two- or three-dimensional scanning, when said ablation probe tip is at the pre-defined angle and the pre-defined depth.

13. The tooth bud ablation probe system of claim 1 wherein said ablation probe tip is guidable by said at least one surgical guide so that said center of ablation is positioned within less than 25% of an average diameter of the tooth bud from the middle of the tooth bud, as determined using two- or three-dimensional scanning, when said ablation probe tip is at the pre-defined angle and the pre-defined depth.

14. The tooth bud ablation probe system of claim 1 wherein said ablation probe tip is guidable by said at least one surgical guide so that said center of ablation is positioned within less than 10% of an average diameter of the tooth bud from the middle of the tooth bud, as determined using two- or three-dimensional scanning, when said ablation probe tip is at the pre-defined angle and the pre-defined depth.

15. The tooth bud ablation probe system of claim 1, said surgical stent being a bone-supported surgical stent contoured to physically seat in a patient's mouth and be supported by bone.

16. The tooth bud ablation probe system of claim 1, said surgical stent having two surgical guides, the position of each surgical guide based upon the location of a tooth bud to be ablated.

17. The tooth bud ablation probe system of claim 1, said shaft of said ablation probe tip having an outer circumference, said passageway of said surgical stent having an inner circumference, said outer circumference being slightly smaller than said inner circumference to allow said passageway to guide said shaft of said ablation probe tip only at the pre-defined angle defined by said at least one surgical guide.

31

18. An ablation probe tip, surgical stent, and ablation probe unit, said ablation probe unit including a generator and a hand piece, said generator being a MW generator for generating MW energy or an RF generator for generating RF energy, the ablation probe tip for use in a tooth bud ablation procedure that results in tooth agenesis, said ablation probe tip, surgical stent, and ablation probe unit comprising:

- (a) said ablation probe tip having a shaft, said shaft having an insertion end and an end for connecting said ablation probe tip to said hand piece;
- (b) said ablation probe tip having a center of ablation at said insertion end;
- (c) said surgical stent having at least one surgical guide, each said surgical guide being a passageway through said surgical stent, each said passageway sized to guide said shaft of said ablation probe tip at a pre-defined angle defined by said at least one surgical guide when used in conjunction with the surgical stent, the pre-defined angle being based on information about the position of a tooth bud obtained from a volume scan image, said surgical stent being a surgical stent contoured to physically seat in a patient's mouth and be supported by at least one tooth, by soft tissue, or by at least one tooth and soft tissue; and

- (d) said ablation probe tip having mechanical stop structure that physically limits the depth of said ablation probe tip to a pre-defined depth when used in conjunction with said surgical stent, the pre-defined depth being based on information obtained from a volume scan image, said mechanical stop structure being a bottom surface of an annular ring or a bottom surface of a shoulder;

wherein when said surgical stent is physically seated so that said at least one surgical guide corresponds to at least one tooth bud surgical site, said ablation probe tip is guidable at said pre-defined angle and limited to said pre-defined depth so that said center of ablation is in the middle of said tooth bud.

19. The ablation probe tip, surgical stent, and ablation probe unit of claim 18, said surgical stent having two surgical guides, the position of each surgical guide based upon the location of a tooth bud to be ablated.

20. The ablation probe tip, surgical stent, and ablation probe unit of claim 18, said shaft of said ablation probe tip having an outer circumference, said passageway of said surgical stent having an inner circumference, said outer circumference being slightly smaller than said inner circumference to allow said passageway to guide said shaft of said ablation probe tip only at the pre-defined angle defined by said at least one surgical guide.

21. An ablation probe tip, a surgical stent, and an ablation probe unit, said ablation probe unit including a generator and a hand piece, said generator being a MW generator for generating MW energy or an RF generator for generating RF energy, said ablation probe tip for use in a tooth bud ablation procedure that results in tooth agenesis, said ablation probe tip, surgical stent, and ablation probe unit comprising:

- (a) said ablation probe tip having a shaft, said shaft having an insertion end and an end for connecting said ablation probe tip to said hand piece, said ablation probe tip being a self-introducing ablation probe tip for making a surgical access path;
- (b) said ablation probe tip having a center of ablation at said insertion end,
- (c) said surgical stent having at least one surgical guide, each said surgical guide being a passageway through said surgical stent, each said passageway sized to guide

32

said shaft of said ablation probe tip at a pre-defined angle defined by said at least one surgical guide when used in conjunction with said surgical stent, said surgical stent being a surgical stent contoured to physically seat in a patient's mouth and be supported by at least one tooth, by soft tissue, or by at least one tooth and soft tissue;

- (d) said ablation probe tip having at least one temperature sensor positioned on said ablation probe tip at a location selected from the group consisting of: said insertion end of said ablation probe tip and along said shaft of said ablation probe tip; and
- (e) said ablation probe tip having mechanical stop structure that physically limits the depth of said ablation probe tip to a pre-defined depth when used in conjunction with said surgical stent, said mechanical stop structure being a bottom surface of an annular ring or a bottom surface of a shoulder;

wherein when said surgical stent is physically seated so that said at least one surgical guide corresponds to at least one tooth bud surgical site, said ablation probe tip is then guidable at said pre-defined angle and limited to said pre-defined depth so that said center of ablation is in the middle of a tooth bud.

22. The said ablation probe tip, surgical stent, and ablation probe unit of claim 21, said surgical stent having two surgical guides, the position of each surgical guide based upon the location of a tooth bud to be ablated.

23. The said ablation probe tip, surgical stent, and ablation probe unit of claim 21, said shaft of said ablation probe tip having an outer circumference, said passageway of said surgical stent having an inner circumference, said outer circumference being slightly smaller than said inner circumference to allow said passageway to guide said shaft of said ablation probe tip only at the pre-defined angle defined by said at least one surgical guide.

24. A tooth bud ablation probe system for use in a tooth bud ablation procedure that results in tooth agenesis, said tooth bud ablation probe system comprising:

- (a) an ablation probe unit and an ablation probe tip, said ablation probe unit including a generator and a hand piece, said generator being a MW generator for generating MW energy or an RF generator for generating RF energy;
- (b) said ablation probe tip having a shaft, said shaft having an insertion end and an end for connecting said ablation probe tip to the hand piece, said ablation probe tip having a center of ablation;
- (c) a surgical stent having at least one surgical guide, each said surgical guide being a passageway through said surgical stent, each said passageway sized to guide said shaft of said ablation probe tip at a pre-defined angle defined by said at least one surgical guide, said surgical stent being a surgical stent contoured to physically seat in a patient's mouth and be supported by at least one tooth, by soft tissue, or by at least one tooth and soft tissue; and
- (d) said ablation probe tip having mechanical stop structure that physically limits the depth of said ablation probe tip to a pre-defined depth in relation to the surgical stent, said mechanical stop structure being a bottom surface of an annular ring or a bottom surface of a shoulder;

wherein when said surgical stent is physically seated so that said at least one surgical guide corresponds to at least one tooth bud surgical site, said ablation probe tip is then guidable at said pre-defined angle and limited to

33

said pre-defined depth so that said center of ablation is in a tooth bud when said ablation probe tip is inserted through at least one surgical guide of the physically seated surgical stent at the pre-defined angle and the pre-defined depth.

25. The said ablation probe tip, surgical stent, and ablation probe unit of claim 24, said surgical stent having two surgical guides, the position of each surgical guide based upon the location of a tooth bud to be ablated.

26. The said ablation probe tip, surgical stent, and ablation probe unit of claim 24, said shaft of said ablation probe tip having an outer circumference, said passageway of said surgical stent having an inner circumference, said outer circumference being slightly smaller than said inner circumference to allow said passageway to guide said shaft of said ablation probe tip only at the pre-defined angle defined by said at least one surgical guide.

27. A method for using a tooth bud ablation probe system for use in a tooth bud ablation procedure that results in tooth agenesis, said method comprising:

- (a) providing an ablation probe unit and an ablation probe tip:
 - (i) said ablation probe unit including a generator and a hand piece, said generator being a MW generator for generating MW energy or an RF generator for generating RF energy;
 - (ii) said ablation probe tip having a shaft, said shaft having an insertion end and an end for connecting

34

said ablation probe tip to the hand piece, said ablation probe tip having mechanical stop structure, said mechanical stop structure being a bottom surface of an annular ring or a bottom surface of a shoulder, said ablation probe tip having a center of ablation;

- (b) providing a surgical stent having at least one surgical guide, each said surgical guide being a passageway through said surgical stent, each said passageway sized to guide said shaft of said ablation probe tip at a pre-defined angle defined by said at least one surgical guide, said surgical stent being a surgical stent contoured to physically seat in a patient's mouth and be supported by at least one tooth, by soft tissue, or by at least one tooth and soft tissue;
- (c) physically seating said surgical stent so that said at least one surgical guide corresponds to at least one tooth bud surgical site;
- (d) inserting said ablation probe tip through at least one surgical guide of the physically seated surgical stent;
- (e) guiding said shaft of said ablation probe tip at a pre-defined angle defined by said at least one surgical guide;
- (f) physically limiting the depth of said ablation probe tip to a pre-defined depth in relation to the surgical stent using said mechanical stop structure; and
- (g) after steps (a)-(f), positioning said center of ablation in a tooth bud, ablating said tooth bud.

* * * * *