



(12) **United States Patent**
Colby

(10) **Patent No.:** **US 9,402,693 B2**
(45) **Date of Patent:** **Aug. 2, 2016**

(54) **THERAPEUTIC TOOTH BUD ABLATION**

USPC 433/32, 74-76, 81, 82, 173, 175,
433/213-215; 703/3

(75) Inventor: **Leigh E. Colby**, Eugene, OR (US)

See application file for complete search history.

(73) Assignee: **Triagenics, LLC**, Eugene, OR (US)

(56) **References Cited**

(*) Notice: Subject to any disclaimer, the term of this patent is extended or adjusted under 35 U.S.C. 154(b) by 687 days.

U.S. PATENT DOCUMENTS

752,378 A 2/1904 Dailey
1,713,971 A 5/1929 Lowry et al.

(Continued)

(21) Appl. No.: **12/863,183**

FOREIGN PATENT DOCUMENTS

(22) PCT Filed: **May 10, 2010**

GB 2057888 4/1981
WO WO2007/057902 5/2007

(86) PCT No.: **PCT/US2010/034259**

(Continued)

§ 371 (c)(1),
(2), (4) Date: **Jul. 15, 2010**

OTHER PUBLICATIONS

(87) PCT Pub. No.: **WO2010/132368**

Prevention of Third molar tooth development in neonate rat with a long pulse diode laser, Silvestri et al. Lasers in Surgery and Medicine 35:385-391 (2004).*

PCT Pub. Date: **Nov. 18, 2010**

(Continued)

(65) **Prior Publication Data**

US 2011/0104632 A1 May 5, 2011

Primary Examiner — Nicholas Lucchesi

Assistant Examiner — Matthew Saunders

Related U.S. Application Data

(74) *Attorney, Agent, or Firm* — Law Office of Karen Dana Oster, LLC

(60) Provisional application No. 61/177,143, filed on May 11, 2009.

(57) **ABSTRACT**

(51) **Int. Cl.**
A61C 13/28 (2006.01)
A61C 1/08 (2006.01)
(Continued)

An ablation procedure. The ablation procedure may be applied to tooth buds **120** and result in tooth agensis. The ablation procedure may be applied to lesions or tumors. A tooth bud ablation system for use in a tooth bud ablation procedure that results in tooth agensis. A method for volume scanning both hard tissues and soft tissues of a patient. A method for manufacturing or fabricating a custom surgical stent **110**. A custom surgical stent **110** for use in a tooth bud ablation procedure that results in tooth agensis, the custom surgical stent **110** for use with an ablation probe tip **108** having a center of ablation **130a**.

(52) **U.S. Cl.**
CPC . *A61C 1/082* (2013.01); *A61C 3/00* (2013.01);
A61C 5/023 (2013.01); *Y10T 29/49826*
(2015.01)

48 Claims, 29 Drawing Sheets

(58) **Field of Classification Search**
CPC .. *A61C 13/0028*; *A61C 19/04*; *A61B 5/0534*;
A61B 5/045; *A61B 5/04*

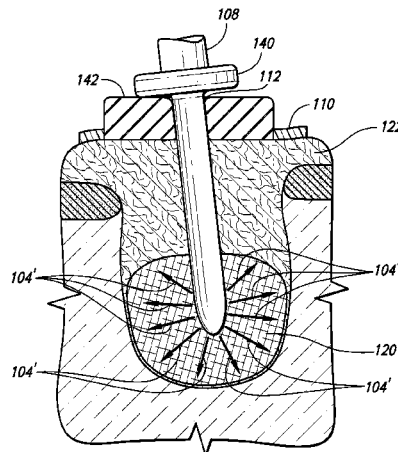

(51)	Int. Cl.		2011/0200960 A1	8/2011	Colby
	A61C 3/00	(2006.01)	2011/0200961 A1	8/2011	Colby
	A61C 5/02	(2006.01)	2013/0017507 A1	1/2013	Moffison et al.

FOREIGN PATENT DOCUMENTS

WO	WO 2007/057902 A3	5/2007
WO	WO2008/067334	6/2008
WO	WO 2008/067334 A3	6/2008
WO	WO2010132368	11/2010

(56) **References Cited**

U.S. PATENT DOCUMENTS

4,672,963	A	6/1987	Barken	
4,895,517	A	1/1990	Fischer	
4,925,523	A	5/1990	Braren et al.	
5,015,183	A	5/1991	Fenick	
5,133,660	A	7/1992	Fenick	
5,556,278	A	9/1996	Meitner	
5,613,852	A	3/1997	Bavitz	
5,642,997	A	7/1997	Gregg, II et al.	
5,688,118	A	11/1997	Hayka et al.	
5,725,376	A	3/1998	Poirier	
5,768,134	A	6/1998	Swaelens et al.	
5,800,168	A	9/1998	Cascione et al.	
5,816,814	A *	10/1998	Venta et al.	433/215
5,843,021	A *	12/1998	Edwards et al.	604/22
5,851,112	A	12/1998	Daikuzono et al.	
5,967,777	A	10/1999	Klein et al.	
6,027,497	A	2/2000	Daniel et al.	
6,162,052	A	12/2000	Kokubu	
6,179,803	B1	1/2001	Edwards et al.	
6,179,830	B1	1/2001	Kokubu	
6,210,355	B1 *	4/2001	Edwards et al.	604/22
6,319,006	B1 *	11/2001	Scherer et al.	433/215
6,386,869	B1	5/2002	Zegarelli	
6,607,524	B1	8/2003	LaBudde et al.	
6,621,491	B1 *	9/2003	Baumrind et al.	345/419
6,622,731	B2	9/2003	Daniel et al.	
6,936,046	B2 *	8/2005	Hissong et al.	606/27
6,971,877	B2	12/2005	Harter	
7,014,461	B2	3/2006	Weinstein	
7,097,451	B2	8/2006	Tang	
7,249,952	B2	7/2007	Ranta et al.	
7,457,443	B2	11/2008	Persky	
7,615,047	B2	11/2009	Berna et al.	
7,787,132	B2	8/2010	Korner et al.	
7,812,815	B2	10/2010	Banerjee et al.	
7,819,591	B2	10/2010	Rohaly et al.	
7,990,548	B2	8/2011	Babayoff et al.	
8,013,853	B1	9/2011	Douglas et al.	
8,048,067	B2	11/2011	Davalos et al.	
8,221,121	B2	7/2012	Berckmans, III et al.	
8,257,341	B1	9/2012	Fletcher	
8,310,683	B2	11/2012	Babayoff et al.	
8,363,228	B2	1/2013	Babayoff	
8,372,061	B2	2/2013	Berna et al.	
2002/0160337	A1	10/2002	Klein et al.	
2004/0102767	A1	5/2004	Stingl et al.	
2004/0158194	A1	8/2004	Wolff et al.	
2004/0219482	A1	11/2004	Bina et al.	
2004/0249370	A1 *	12/2004	Berna et al.	606/14
2005/0170312	A1 *	8/2005	Pond	433/81
2005/0177074	A1	8/2005	Becker et al.	
2005/0283148	A1 *	12/2005	Janssen et al.	606/34
2006/0084958	A1	4/2006	Raif et al.	
2006/0111705	A1 *	5/2006	Janzen et al.	606/41
2006/0115782	A1	6/2006	Li et al.	
2006/0127859	A1	6/2006	Wen	
2006/0195169	A1 *	8/2006	Gross et al.	607/116
2007/0224570	A1	9/2007	West et al.	
2007/0265628	A1	11/2007	Kraus et al.	
2008/0138761	A1	6/2008	Pond	
2008/0182218	A1	7/2008	Chen et al.	
2008/0199829	A1 *	8/2008	Paley et al.	433/215
2009/0253095	A1	10/2009	Salcedo et al.	
2009/0258330	A1	10/2009	Huber et al.	
2009/0263764	A1	10/2009	Berckmans, III et al.	
2010/0100094	A1	4/2010	Truckai	
2010/0203479	A1	8/2010	Bulloch et al.	
2010/0311028	A1	12/2010	Bell, III et al.	
2010/0316974	A1	12/2010	Yau et al.	
2011/0104632	A1	5/2011	Colby	

OTHER PUBLICATIONS

Selectively preventing development of third molars in rats using electrosurgical energy, Silvestri et al., ADA, vol. 135, pp. 1397-1405, Oct. 2004.*

Patent Cooperation Treaty, International Searching Authority, International Search Report and Written Opinion (PCT/US13/32357), Jun. 5, 2013.

Australian Government, IP Australia, Patent Examination Report No. 1 (2010247874), Jan. 2, 2014.

Dodson et al.; "Introduction;" © 2012 American Association of Oral and Maxillofacial Surgeons; © 2012 American Association of Oral and Maxillofacial Surgeons <http://dx.doi.org/10.1016/j.joms.2012.04.022>; Journal of Oral and Maxillofacial Surgery, vol. 70, No. 9, Supplement 1, Sep. 2012; pp. S2-S3; USA.

Dodson et al.; "Summary of the proceedings of the third molar multidisciplinary conference;" © 2012 American Association of Oral and Maxillofacial Surgeons; Journal of Oral and Maxillofacial Surgery, <http://dx.doi.org/10.1016/j.joms.2012.05.001>; vol. 70, No. 9, Supplement 1, Sep. 2012; pp. S66-S69; USA.

Fox, M.; "Shots kill budding wisdom teeth, study suggests;" © NBCNews.com; Apr. 2013; http://vitals.nbcnews.com/_news/2013/04/03/17584797-shots-kill-budding-wisdom-teeth-study-suggests%0D%0A%0D%0ANBCNews.com; New York, NY.

Harrison, L.; "Nerve blocks in children may destroy future molars;" © 2013 WebMD, LLC; Medscape Medical News; Apr. 8, 2013; www.medscape.com; pp. 1-2, USA.

Kusek, K.; "Researchers use light to coax stem cells to repair teeth;" © 2013 President and Fellows of Harvard College; Harvard School of Engineering and Applied Sciences; Wyss Institute; May 28, 2014; <http://www.seas.harvard.edu/news/2014/05/researchers-use-light-to-coax-stem-cells-to-repair-teeth>; pp. 1-6; Cambridge/Boston, MA, USA.

Levin, D.; "Nipping wisdom teeth in the bud: childhood anesthesia may thwart the development of third molars;" © 2014 Tufts University; Tufts Dental Medicine, Fall 2013; <http://now.tufts.edu/articles/nipping-wisdom-teeth-bud>; 1 page; Boston, MA, USA.

Pogrel, M.A.; "What is the effect of timing of removal on the incidence and severity of complications?;" © 2012 American Association of Oral and Maxillofacial Surgeons; Journal of Oral and Maxillofacial Surgery; <http://dx.doi.org/10.1016/j.joms.2012.04.028>; vol. 70, No. 9, Supplement 1, Sep. 2012; pp. S37-S40; USA.

Ricketts, R.M. et al.; "Third molar enucleation: diagnosis and technique;" Journal—California Dental Association; Apr. 1976; <http://www.ncbi.nlm.nih.gov/pubmed/1074850>; pp. 52-57; USA.

Swee, J. et al.; "Inferior alveolar nerve block and third-molar agenesis: a retrospective clinical study;" © 2014 American Dental Association, all rights reserved; JADA 2013; 144(4); <http://jada.ada.com>; pp. 389-395; USA.

Guralnick W.C. et al.; "Removal of third molars;" National Institutes of Health Consensus Development Conference Statement; Nov. 28-30, 1979; NIH Consens Statement Online Nov. 28-30, 1979; 2(11):65-68; USA.

Aaoms; "Advocacy white paper on evidence based third molar surgery;" American Association of Oral and Maxillofacial Surgeons; Nov. 10, 2011; USA.

Pogrel, M.A. et al.; "White paper on third molar data;" American Association of Oral and Maxillofacial Surgeons; Mar. 2007; http://www.aaoms.org/docs/third_molar_white_paper.pdf; pp. 1-25; USA.

(56)

References Cited

OTHER PUBLICATIONS

- Gordon N.C. et al.; "The effects of local hypothermia on odontogenesis," Abstract; Journal of Oral Surgery, Apr. 1979;37(4):235-44; PubMed—indexed for Medline; USA.
- Ahmad et al., "Caries Experience and Periodontal Pathology in Erupting Third Molars," Journal of Oral and Maxillofacial Surgery, 2008; 66(5):948-53 (ISSN: 1531-5053). Chapel Hill, NC 27599, USA.
- Al-Khateeb et al., "Pathology Associated with Impacted Mandibular Third Molars in a Group of Jordanians," Journal of Oral and Maxillofacial Surgery, 2006; 64(11):1598-602. Irbid, Jordan.
- American Association of Oral and Maxillofacial Surgeons, "White Paper on Third Molar Data," Article, Mar. 2007, 25 pages. Published at www.aaoms.org.
- American Dental Association, "Growth in Dental Spending Expected to Slow in 2009," American Dental Association, Feb. 26, 2009, 1 page. Published at www.ada.org.
- American Public Health Association, "Opposition to Prophylactic Removal of Third Molars (Wisdom Teeth)," Policy Statement Database, Policy No. 20085, Oct. 28, 2008. Washington, DC 20001, USA.
- Askboots, "Removing Wisdom Teeth," Web Article, 9 pages, Sep. 21, 2007. BMJ Publishing Group Limited. Published at www.askboots.com.
- Bataineh, A.B., "Sensory Nerve Impairment Following Mandibular Third Molar Surgery," Journal of Oral and Maxillofacial Surgery, 2001; 59(9):1012-7 (ISSN: 0278-2391). Irbid, Jordan.
- Blakey et al., "Impact of Removal of Asymptomatic Third Molars on Periodontal Pathology," Journal of Oral and Maxillofacial Surgery, 2009; 67(2): 245-50. Chapel Hill, NC 27599, USA.
- Blakey et al., "Periodontal Pathology Associated with Asymptomatic Third Molars," Journal of Oral and Maxillofacial Surgery, 2002; 60(11):1227-33 (ISSN: 0278-2391). Chapel Hill, NC 27599, USA.
- Blankenship et al., "Third Molar Development in the Estimation of Chronologic Age in American Blacks as Compared with Whites," Journal of Forensic Science, 2007; 52(2): 428-33. Memphis TN, 38163, USA.
- Blondeau et al., "Extraction of Impacted Mandibular Third Molars: Postoperative Complications and Their Risk Factors," Journal of the Canadian Dental Association, May 2007, vol. 73, No. 4, (ISSN: 1488-2159).
- Bui et al., "Types, Frequencies, and Risk Factors for Complications After Third Molar Extraction," Journal of Oral and Maxillofacial Surgery, 2003; 61:1379-1389, Chapel Hill, NC 27599, USA.
- Christiaens et al. "Complications After Third Molar Extractions: Retrospective Analysis of 1,213 Teeth," Rev Stomatol Chir Maxillofac, 2002; 103(5):269-74 (ISSN: 0035-1768). Belgique, France.
- Dodson, T.B., "Response to APHA C3: Opposition to Prophylactic Removal of Third Molars," Article, Oct. 26, 2008, 3 pages, Massachusetts General Hospital. Boston, MA 02114, USA.
- Eklund et al., "Third-Molar Removal Patterns in an Insured Population," Journal of the American Dental Association, vol. 132, No. 4, 469-475, 2001.
- Elter et al., "Third Molars Associated with Periodontal Pathology in the Third National Health and Nutrition Examination Survey," Journal of Oral and Maxillofacial Surgery, 2004; 62(4):440-5. Chapel Hill, NC 27599, USA.
- Elter et al., "Third Molars Associated with Periodontal Pathology in Older Americans," Journal of Oral and Maxillofacial Surgery, Feb. 2005; 63(2):179-84. Chapel Hill, NC 27599, USA.
- Friedman, J.W., "Containing the Cost of Third-Molar Extractions: A Dilemma for Health Insurance," Public Health Reports, vol. 98, No. 4, pp. 376-384, Jul.-Aug. 1983. Los Angeles, CA 90057, USA.
- Friedman, J.W., "The Prophylactic Extraction of Third Molars: A Public Health Hazard," American Journal of Public Health, vol. 97, No. 9, Sep. 2007. Los Angeles, CA 90064, USA.
- Hicks, E.P., "Third Molar Management: A Case Against Routine Removal in Adolescent and Young Adult Orthodontic Patients," Journal of Oral and Maxillofacial Surgery, 1999; 57(7):831-6. Lexington, KY, USA.
- Huang et al., "Third-Molar Extraction as a Risk Factor for Temporomandibular Disorder," Journal of the American Dental Association, vol. 137, No. 11, pp. 1547-1554. American Dental Association, 2006.
- Jiang, P., "Ten-Year Insurance Claims Data Study Reveals Increase in Utilization of Surgical Extraction Codes," Online Periodical, Winter 2006/2007, 6 pages, Delta Dental of Minnesota. Eagan, MN 55122, USA.
- Kajii et al., "Presence of Third Molar Germs in Orthodontic Patients in Japan," American Journal of Orthodontics & Dentofacial Orthopedics, vol. 119, Issue 3, pp. 245-250, Mar. 2001.
- Kaminishi et al., "A 10-year Comparative Study of the Incidence of Third Molar Removal in the Aging Population," Journal of Oral Maxillofacial Surgery, 2006 ;64(2):173-4 (ISSN: 0278-2391). Los Angeles, CA, USA.
- Kaminishi et al., "New Considerations in the Treatment of Compromised Third Molars," Journal of the California Dental Association, 2004; 32(10):823-5 (ISSN: 1043-2256). Los Angeles, CA.
- Kan et al., "Residual Periodontal Defects Distal to the Mandibular Second Molar 6-36 Months after Impacted Third Molar Extraction," J. Clinical Periodontol, Nov. 2002; 29(11):1004-11. Hong Kong SAR, China.
- Knutsson et al., "Dentists' Decisions on Prophylactic Removal of Mandibular Third Molars: A 10-year Follow-up Study," Community Dental and Oral Epidemiology, 2001; 29(4):308-14. Malmö University, Sweden.
- Kunkel et al., "Severe Third Molar Complications Including Death-Lessons from 100 Cases Requiring Hospitalization," Journal of Oral Maxillofacial Surgery, 2007; 65(9):1700-6. Mainz, Germany.
- Kunkel et al., "Third Molar Complications Requiring Hospitalization," Oral Surg. Oral Med. Oral Pathol. Oral Radiol Endod., 2006; 102(3):300-6 (ISSN: 1528-395X). Mainz, Germany.
- Langsten et al., "The Impact of Retained Third Molars on the Deployed Airman," Military Medicine, vol. 173, Supplement 1, Jan. 2008, pp. 27-28(2). Publisher: AMSUS, Eglin Air Force Base, FL 32542.
- McArdle et al., "Distal Cervical Caries in the Mandibular Second Molar: An Indication for the Prophylactic Removal of the Third Molar?" British Journal of Oral Maxillofacial Surgery, Feb. 2006; 44(1):42-5. London, UK.
- Moss et al., "Third Molar Periodontal Pathology and Caries in Senior Adults," Journal of Oral Maxillofacial Surgery, 2007; 65(1):103-8 (ISSN: 0278-2391). Chapel Hill, NC 27599, USA.
- Nance et al., "Change in Third Molar Angulation and Position in Young Adults and Follow-up Periodontal Pathology," Journal Oral Maxillofacial Surgery, Mar. 2006; 64(3):424-8. Chapel Hill, NC 27599, USA.
- National Institutes of Health, "Removal of Third Molars," NIH Consensus Statement Online, Nov. 28-30, 1979; 2(11):65-8.
- Pratt et al., "Indications for Third Molar Surgery," J. R. Coll. Surg. Edinb., vol. 43., Apr. 1998, pp. 105-108. Portsmouth, UK.
- Rakprasitkul, S., "Pathologic Changes in the Pericoronal Tissues of Unerupted Third Molars," Quintessence International. 2001; 32(8):633-8 (ISSN: 0033-6572). Rajthevee, Bangkok, Thailand 10400.
- Sarnat et al., "Developmental Stages of the Third Molar in Israeli Children," Pediatric Dentistry, 2003; 25 (4):373-7 (ISSN: 0164-1263). Tel Aviv, Israel.
- Shugars et al., "Incidence of Occlusal Dental Caries in Asymptomatic Third Molars," Journal Oral Maxillofacial Surgery, 2005; 63(3):341-6 (ISSN: 0278-2391). Chapel Hill, NC 27599, USA.
- Silvestri et al., "Prevention of Third Molar Development in Dog with Long Pulse Diode Laser: A Preliminary Report," Lasers Surg. Med., 2007; 39(8):674-7 (ISSN: 0196-8092). Boston, MA 02111, USA.
- Silvestri et al., "Prevention of Third Molar Tooth Development in Neonate Rat with a Long Pulse Diode Laser," Lasers Surg. Med., 2004; 35(5):385-91 (ISSN: 0196-8092). Boston, MA 02111, USA.
- Silvestri et al., "Selectively Preventing Development of Third Molars in Rats Using Electrosurgical Energy," Journal of the American Dental Association, vol. 135, No. 10, 1397-1405. Boston, MA 02111, USA.

(56)

References Cited

OTHER PUBLICATIONS

Silvestri et al., "The Unresolved Problem of the Third Molar: Would People be Better Off Without It?" *Journal of the American Dental Association*, vol. 134, No. 4, 450-5. Boston, MA 02111, USA.

Song et al., "The Effectiveness and Cost-Effectiveness of Prophylactic Removal of Wisdom Teeth," Executive Summary, *Health Technology Assessment*, 2000; vol. 4: No. 15.

U.S. Department of Labor, "Dentists," Webpage, 3 pages, last modified Dec. 17, 2009.

University of York, The, "Prophylactic Removal of Impacted Third Molars: Is It Justified?" *Effectiveness Matters*, vol. 3, Issue 2, Oct. 1998. Heslington, York, UK.

Venta et al., "Change in Clinical Status of Third Molars in Adults during 12 Years of Observation," *Journal Oral Maxillofacial Surgery*, 1999; 57(4):386-9 (ISSN: 0278-2391). Helsinki, Finland.

Venta et al., "Malpractice Claims for Permanent Nerve Injuries Related to Third Molar Removals," *Acta Odontol. Scand.*, 1998; 56(4):193-6 (ISSN: 0001-6357). Helsinki, Finland.

Voegelin et al., "Complications during and after Surgical Removal of Mandibular Third Molars. Impact of Patient Related and Anatomical Factors," *Schweiz Monatsschr Zahnmed*, 2008; 118(3):192-8. Bern, Switzerland.

Wikipedia, "Third Molar," Wikipedia, Webpage, 9 pages, last modified Apr. 19, 2011.

Wikipedia, "Tooth Development," Wikipedia, Webpage, 16 pages, last modified Apr. 18, 2011.

Brace, C.L., "Microwave Ablation Technology Avoids Problems that Plaque RFA, Offers Promise for New Applications," *Diagnostic Imaging*, Mar. 13, 2006, 2 pages. Madison, WI 53792.

Brace et al., "Pulmonary Thermal Ablation: Comparison of Radiofrequency and Microwave Devices by Using Gross Pathologic and CT Findings in a Swine Model," *Radiology*, Jun. 2009, vol. 251, 705-11. Madison, WI 53792.

Friedman, J.W., "Opposition to Prophylactic Removal of Third Molars," *APHA Oral Health Section*, Feb. 18, 2008, pp. 1-10.

Kunkel et al., "Guideline: Surgical Removal of Third Molars," *Agency for Quality in Dentistry*, Apr. 2006, pp. 1-16. Cologne, Germany 50931.

Park et al., "Cortical Integrity of the Inferior Alveolar Canal as a Predictor of Paresthesia After Third-Molar Extraction," *Journal of American Dental Association*, 2010; vol. 141, No. 3, 271-8.

Wealthy Dentist, The, "Dental Marketing: Dentists Refer Some Wisdom Tooth Extractions to Oral Surgeons," pp. 1-5. Tiburon, CA 94920.

Patent Cooperation Treaty, *International Search Report*, Sep. 14, 2010.

Patent Cooperation Treaty, *International Preliminary Report on Patentability*, Aug. 31, 2011.

Patent Cooperation Treaty, "Notification of Transmittal of International Preliminary Report on Patentability," and "International Preliminary Report on Patentability," for PCT/US13/32357, at least as early as May 8, 2015, 14 pages.

iTero, "OrthoCAD," "A digitally perfect orthodontic impression," www.cadentic.com, © 2009 Cadent, Ltd., 7 pages.

Patent Cooperation Treaty, *International Preliminary Report on Patentability*, PCT/US10/34259, Aug. 31, 2011.

Patent Cooperation Treaty, *Written Opinion International Search Report*, PCT/US10/34259, Sep. 14, 2010.

* cited by examiner

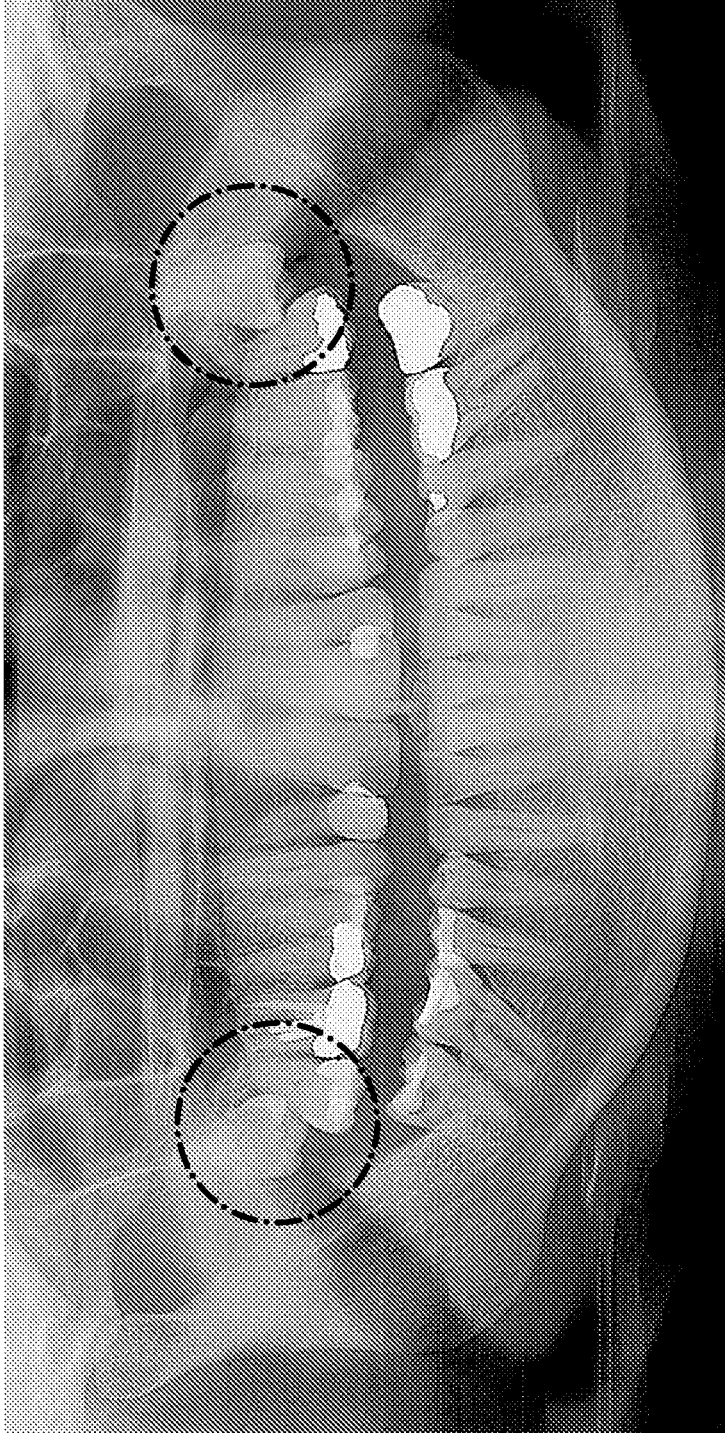

FIG. 1

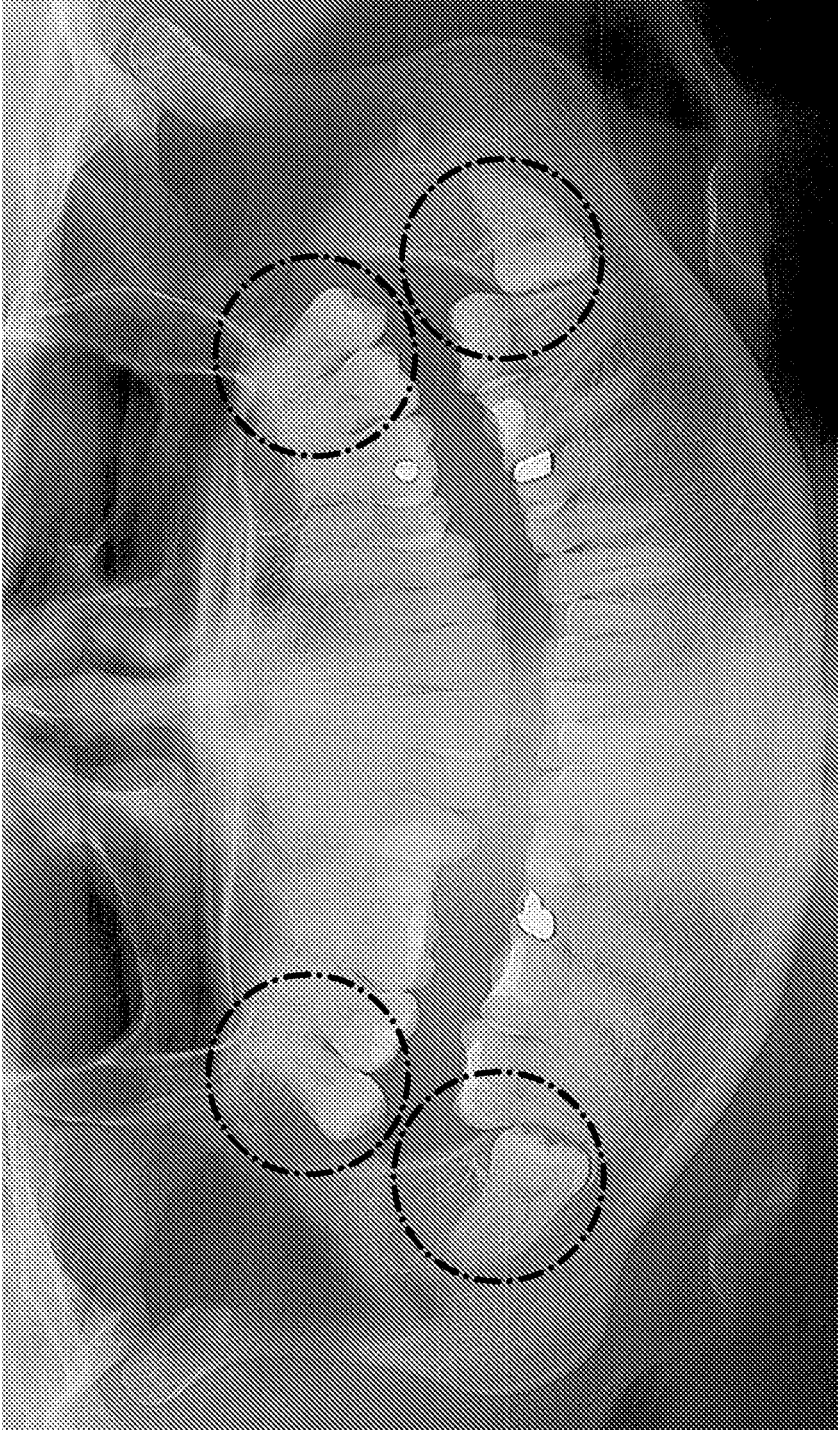

FIG. 2

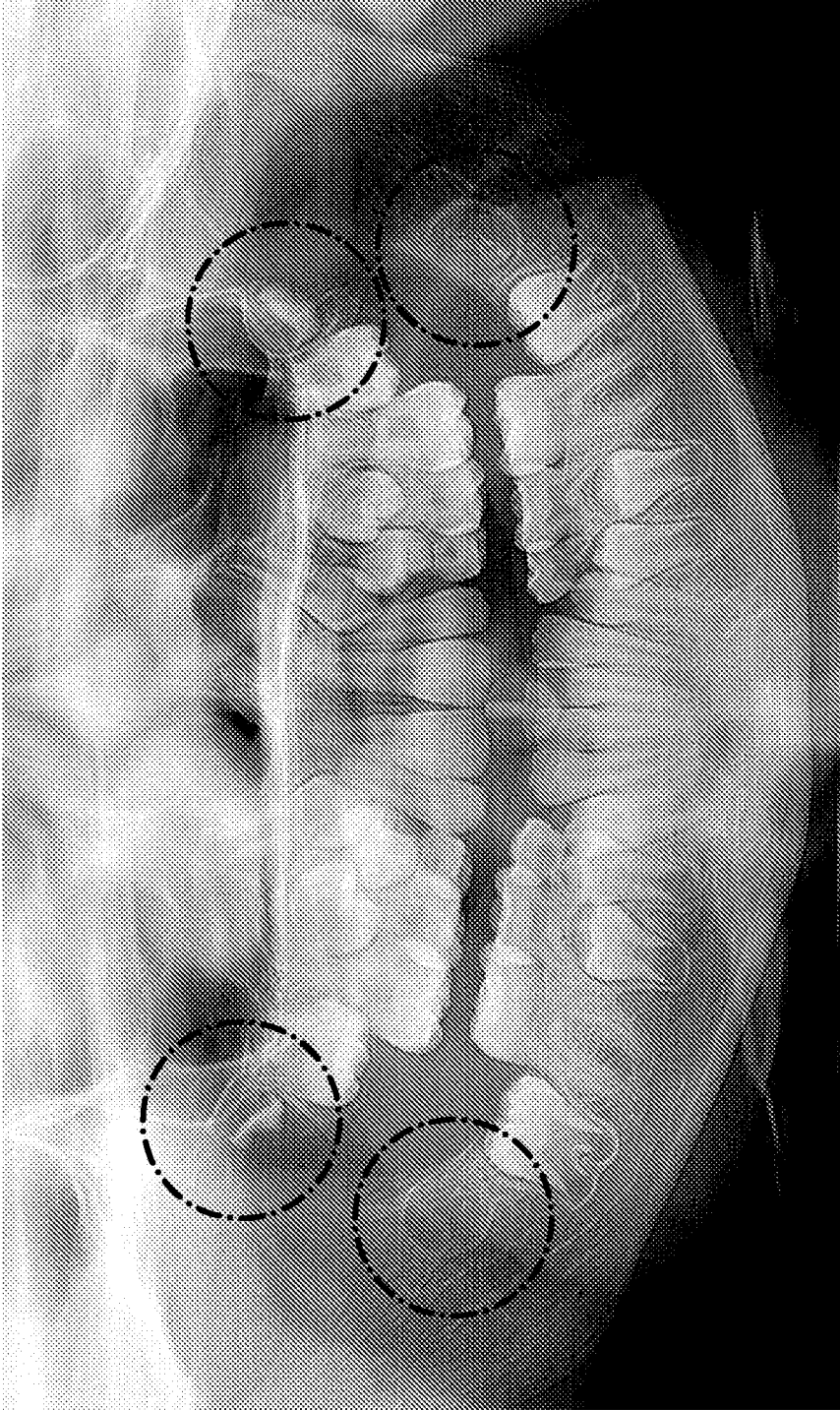

FIG. 3

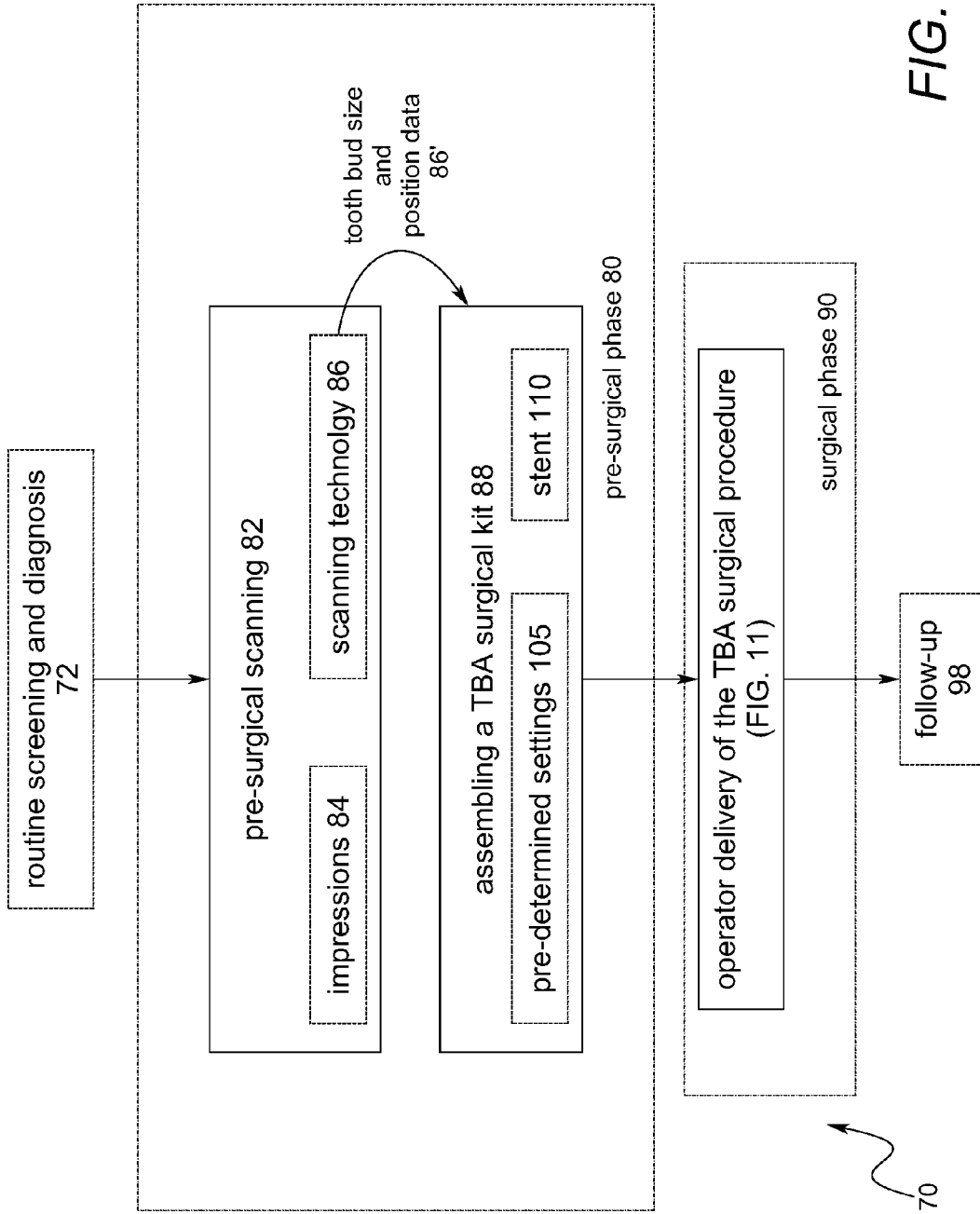

FIG. 4

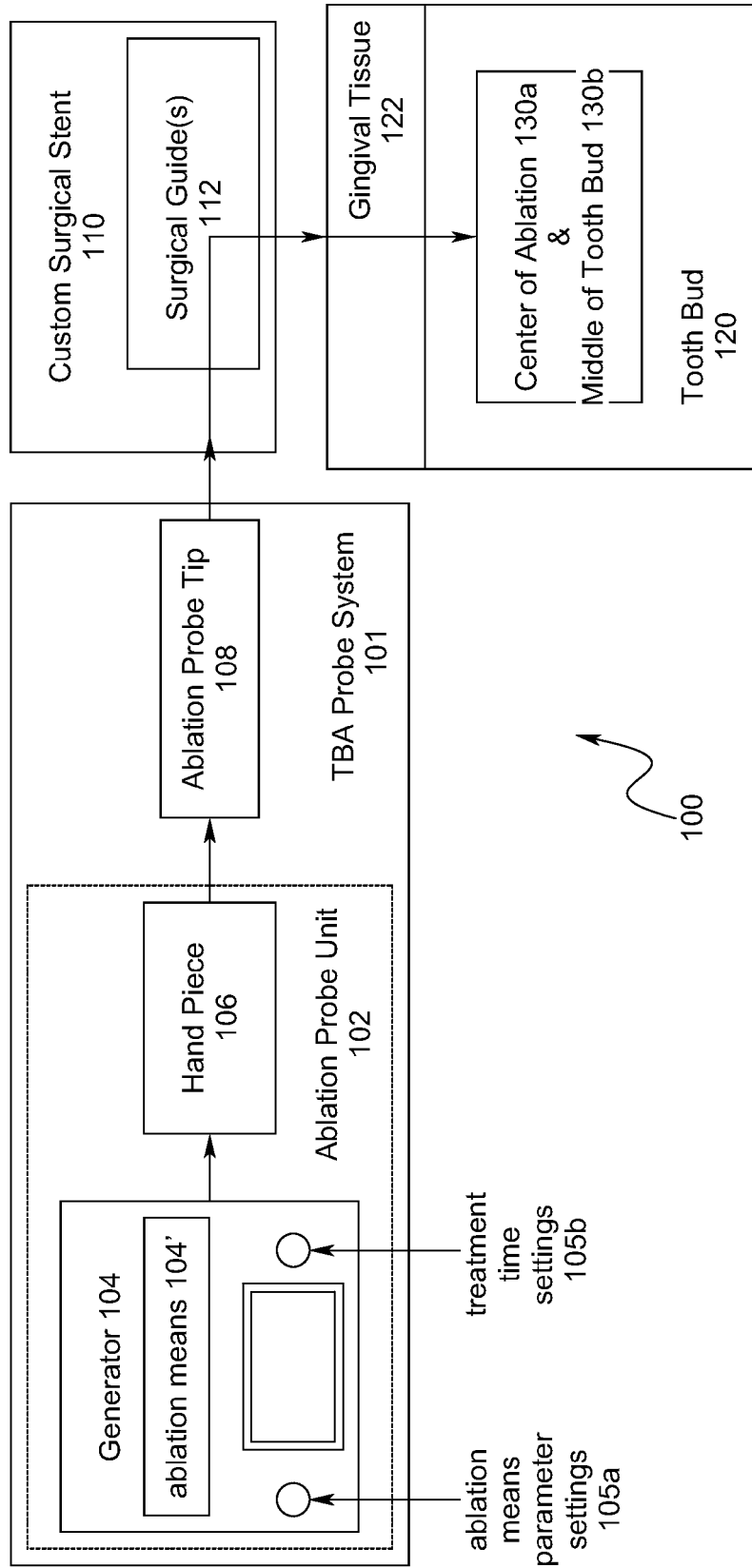

FIG. 5

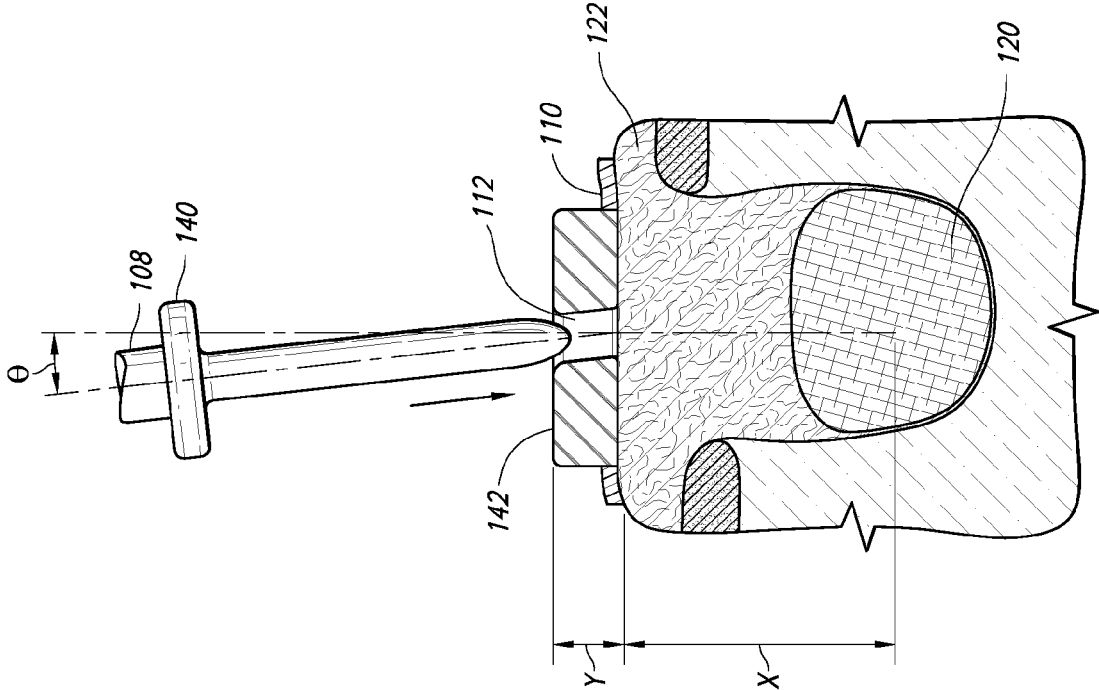

FIG. 6

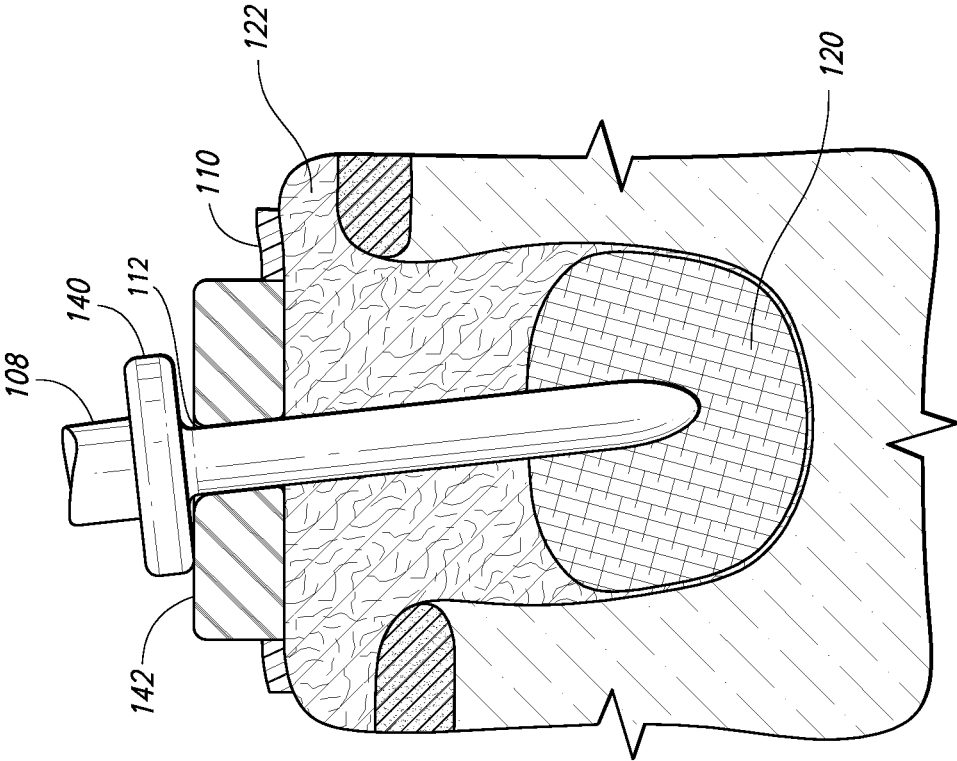

FIG. 7

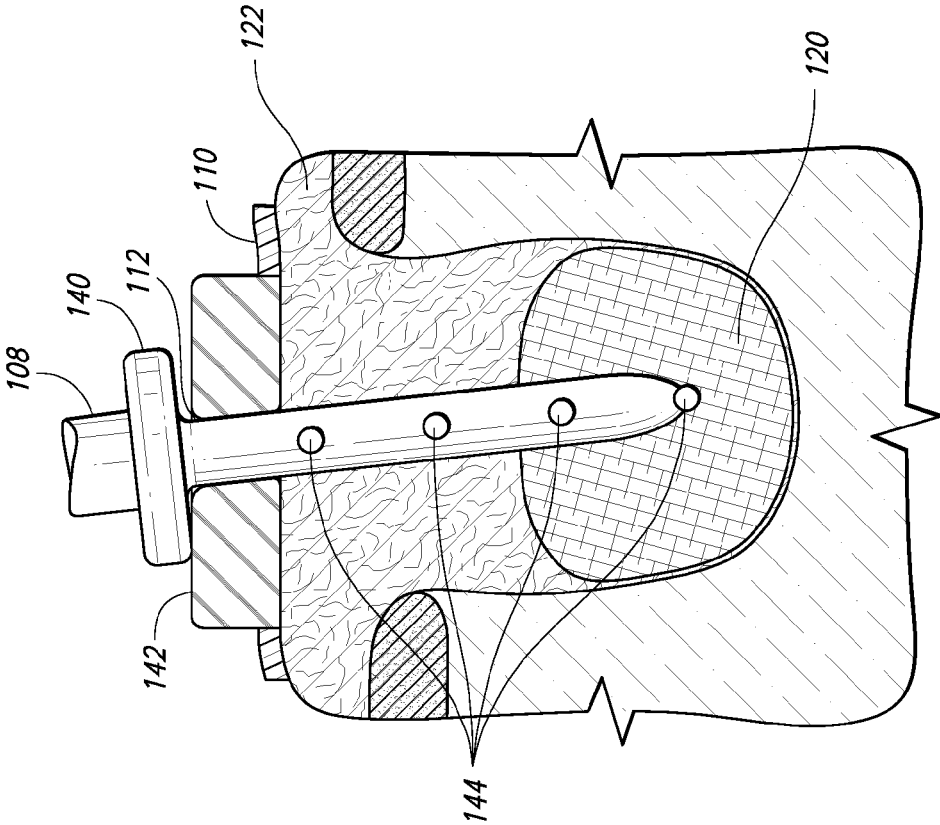

FIG. 8

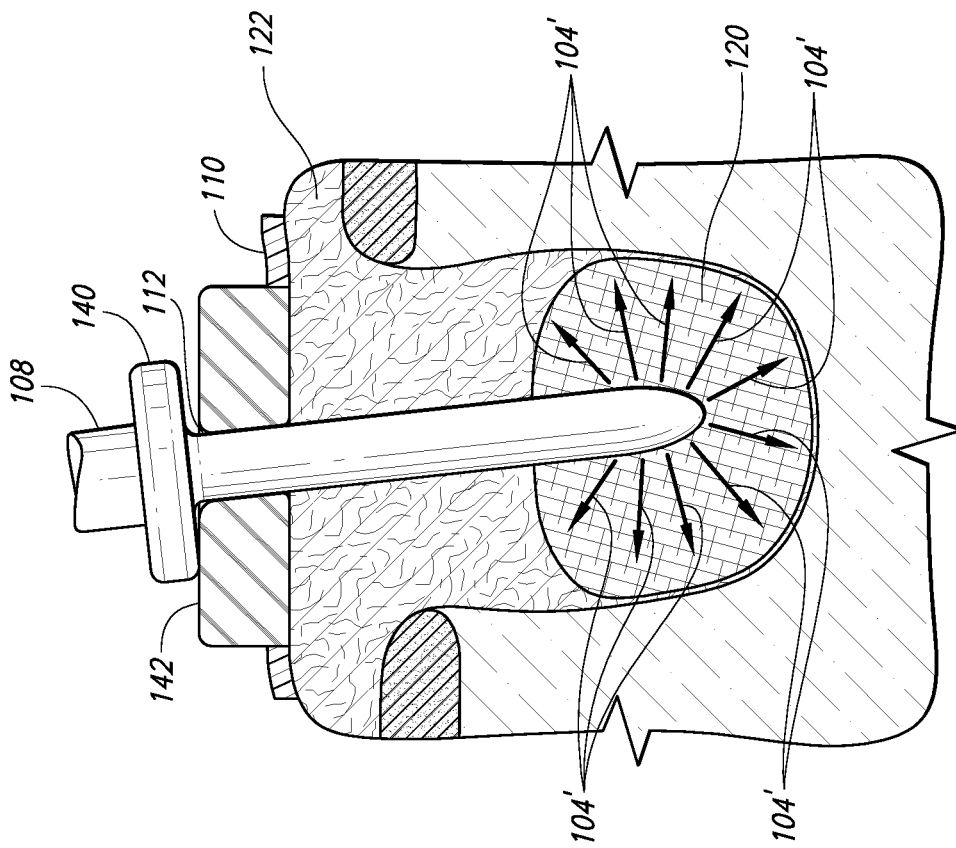

FIG. 9

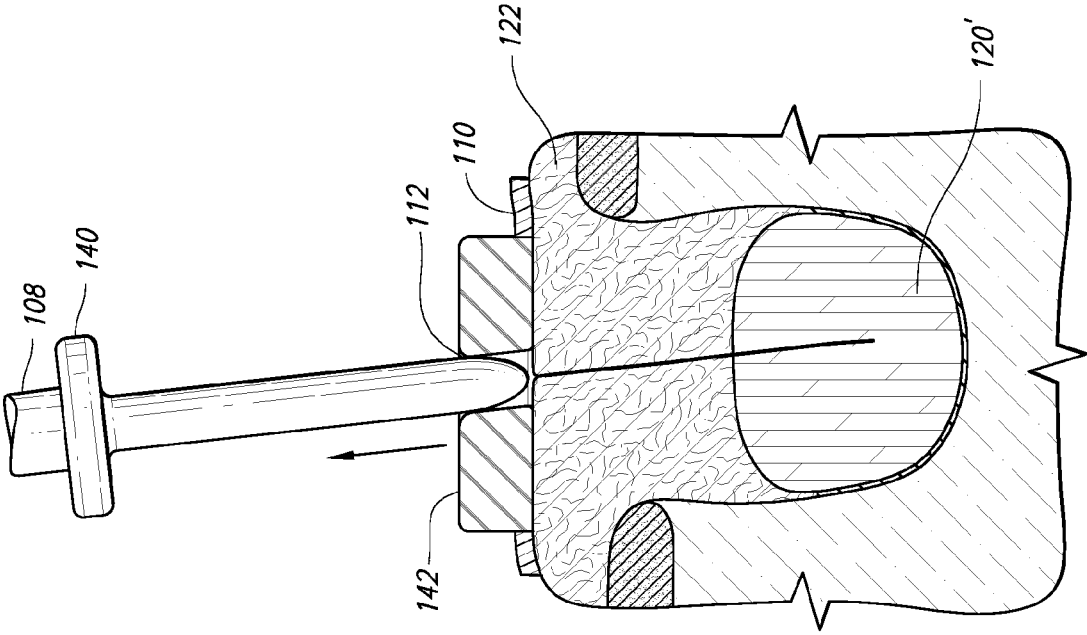
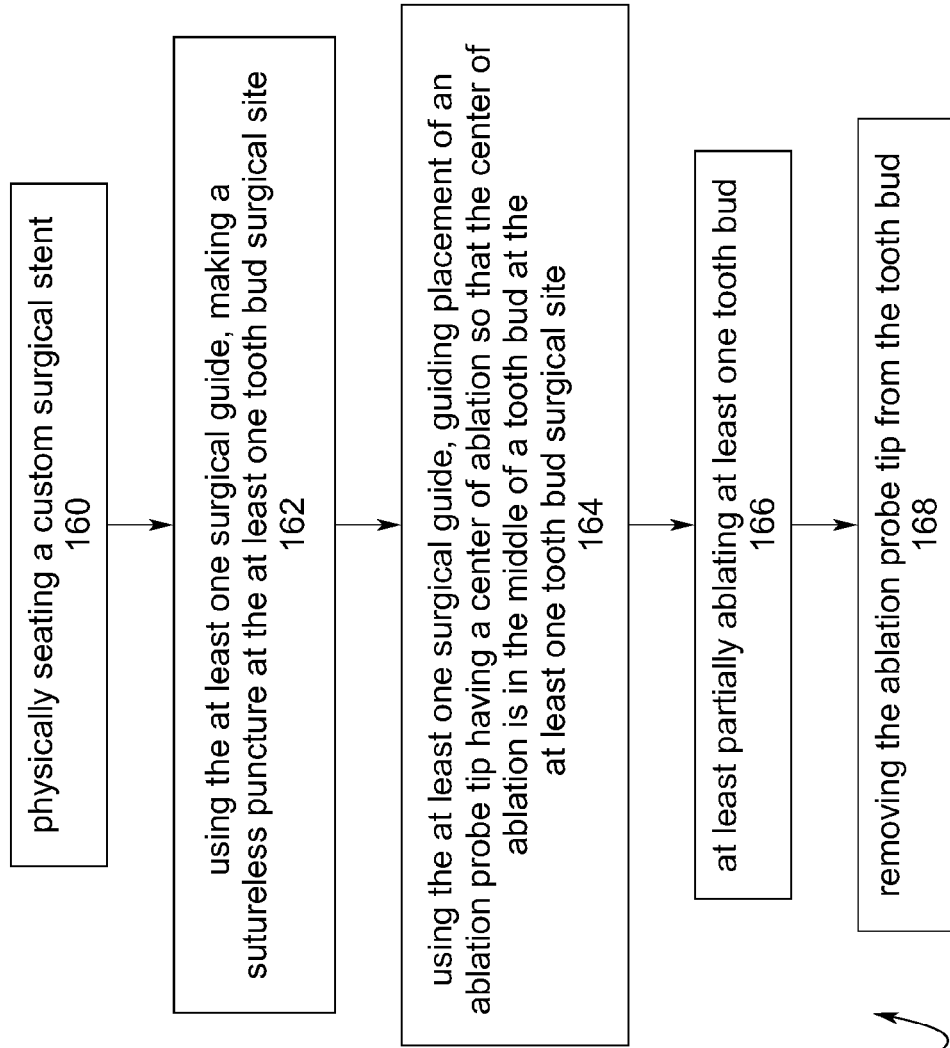

FIG. 10



90

FIG. 11

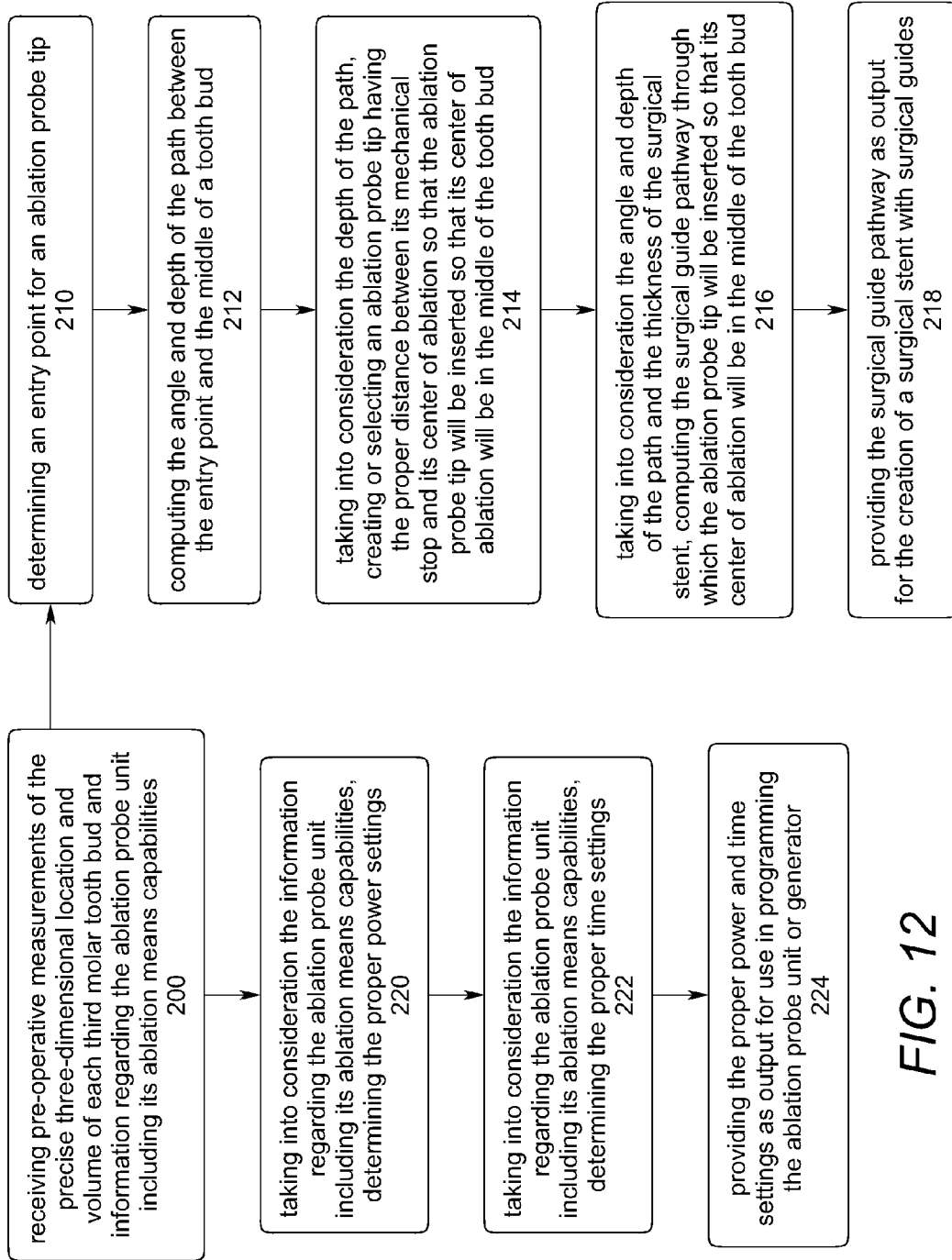

FIG. 12

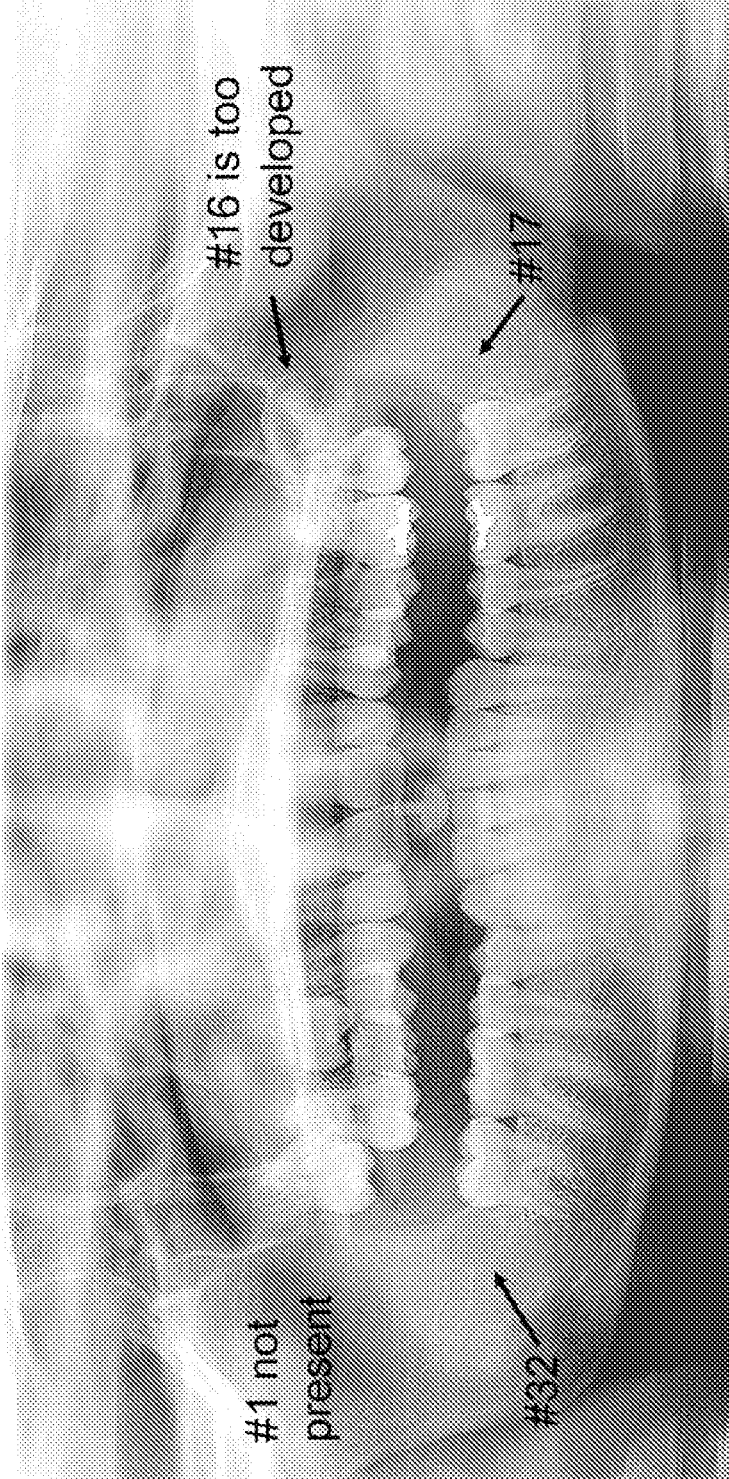

FIG. 13

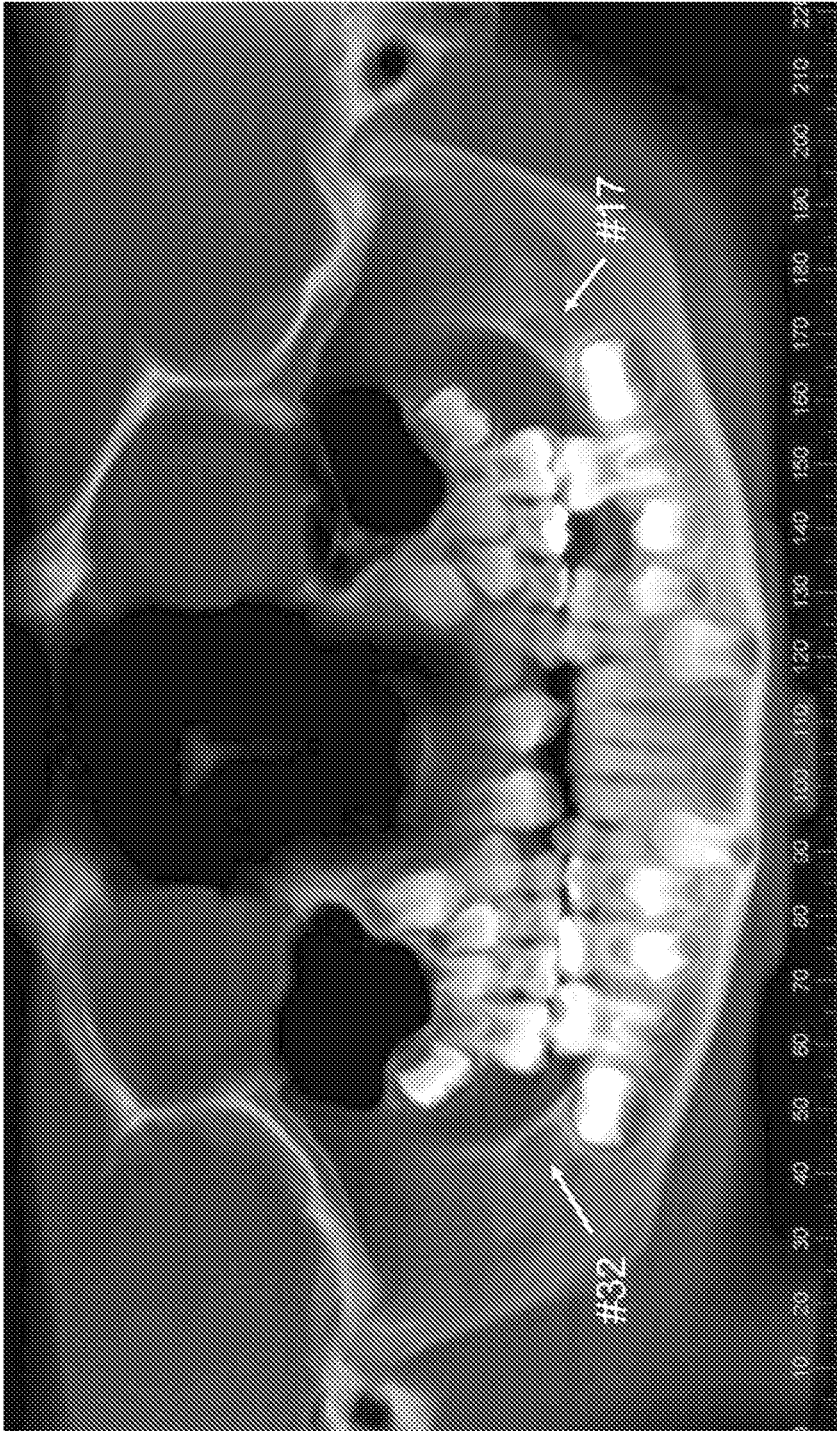

FIG. 14

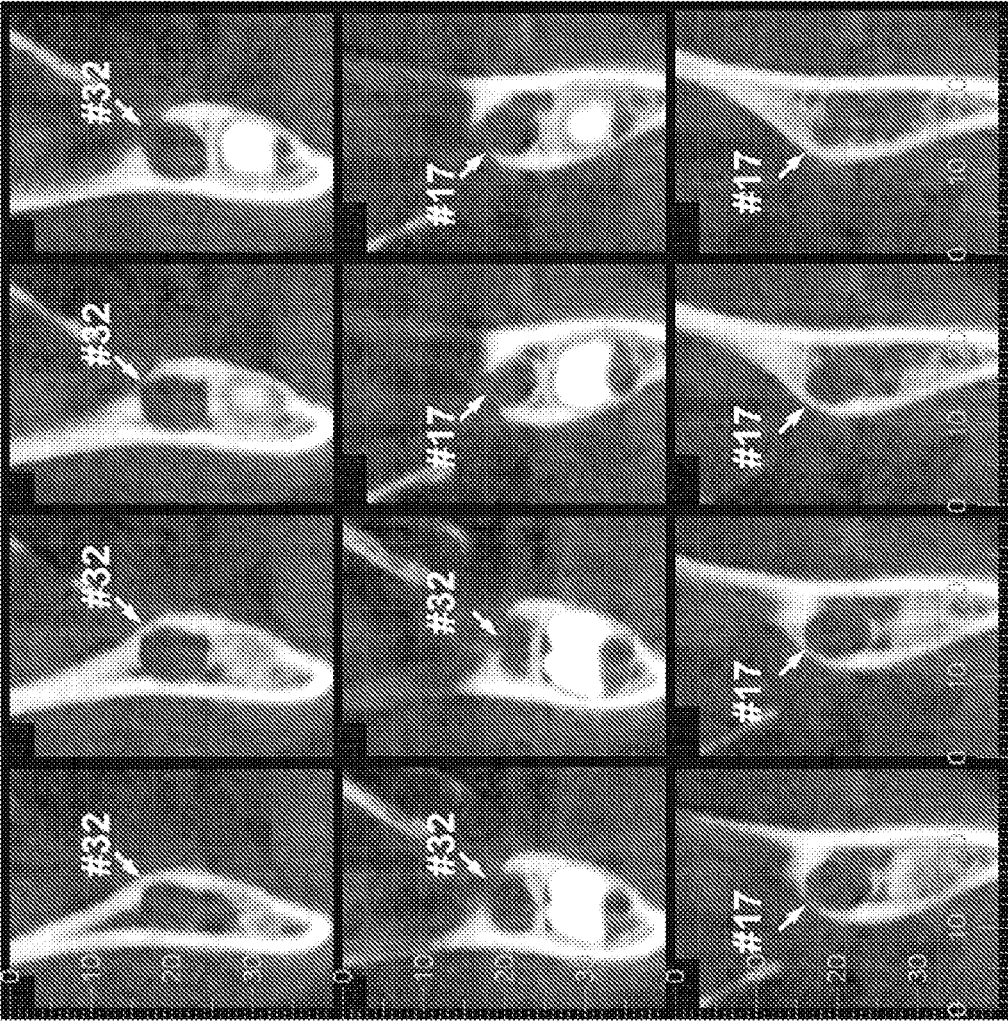

FIG. 15

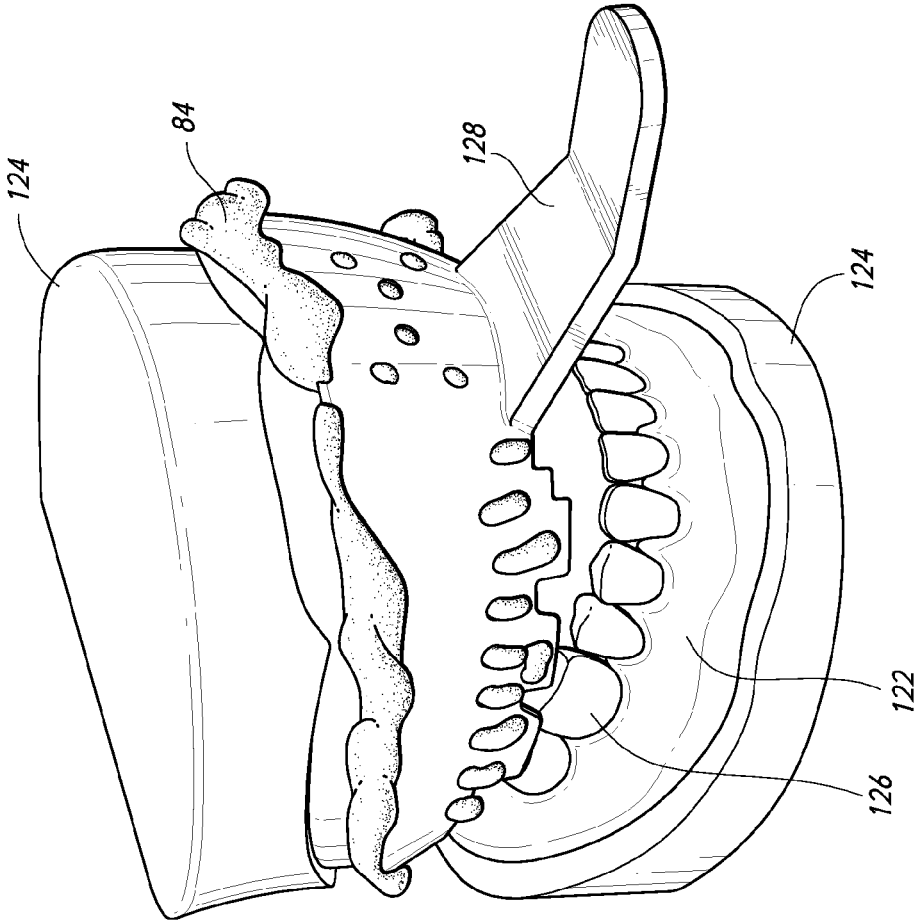

FIG. 16

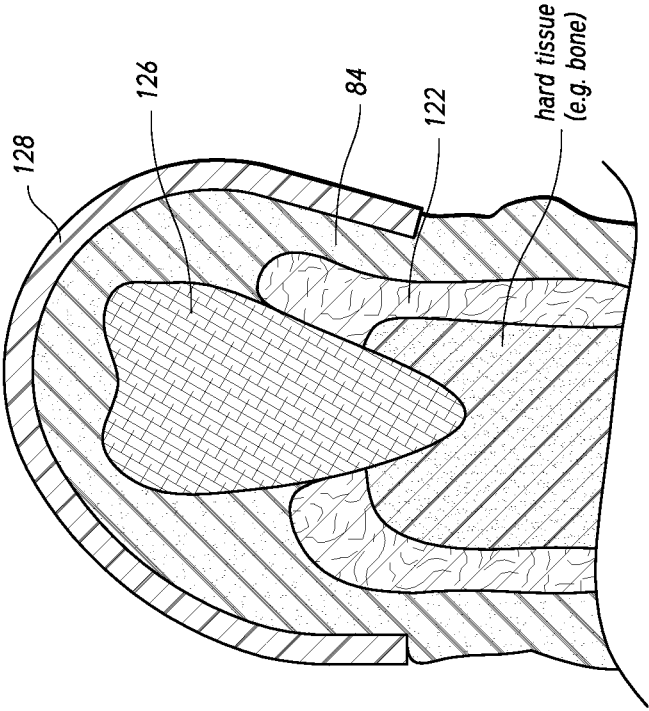

FIG. 17

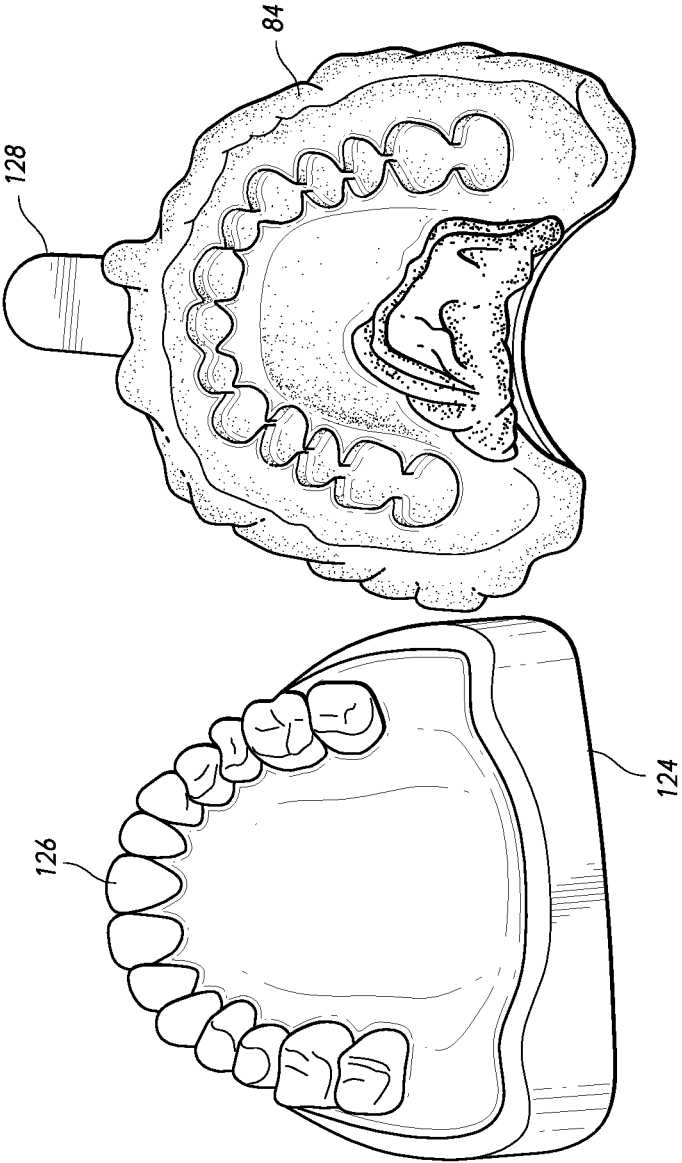

FIG. 18

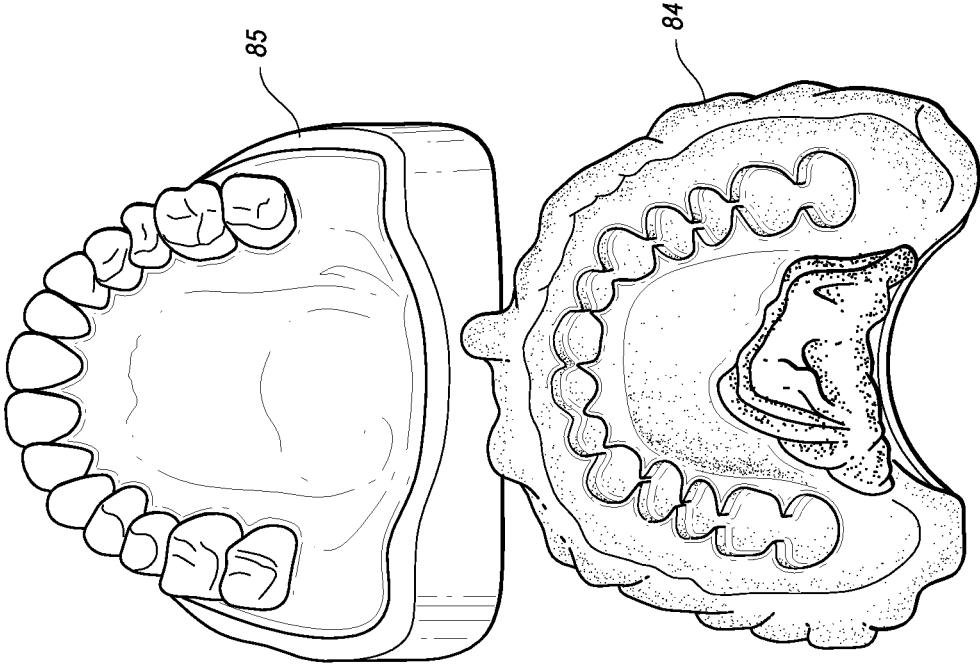

FIG. 19

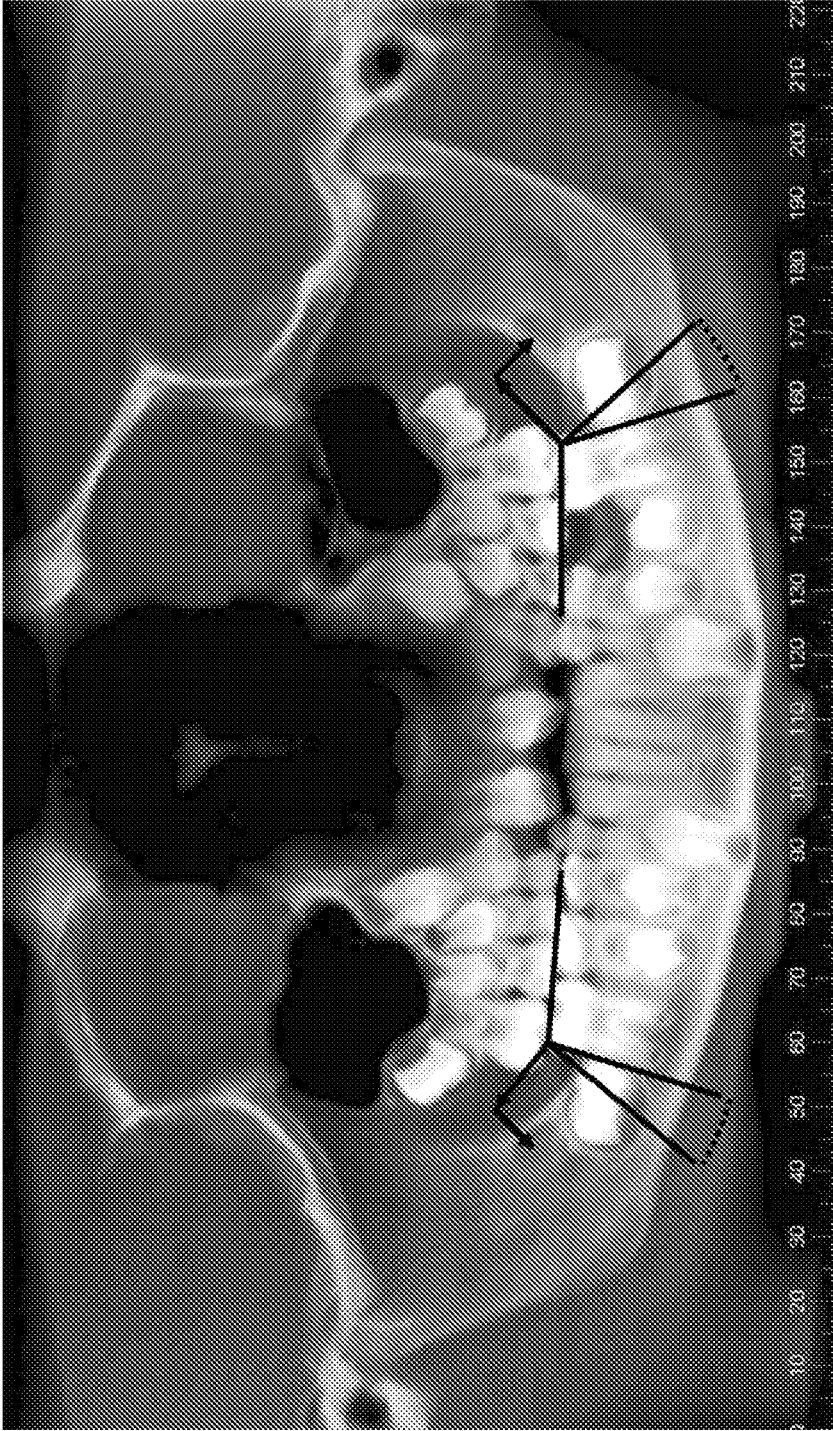

FIG. 20

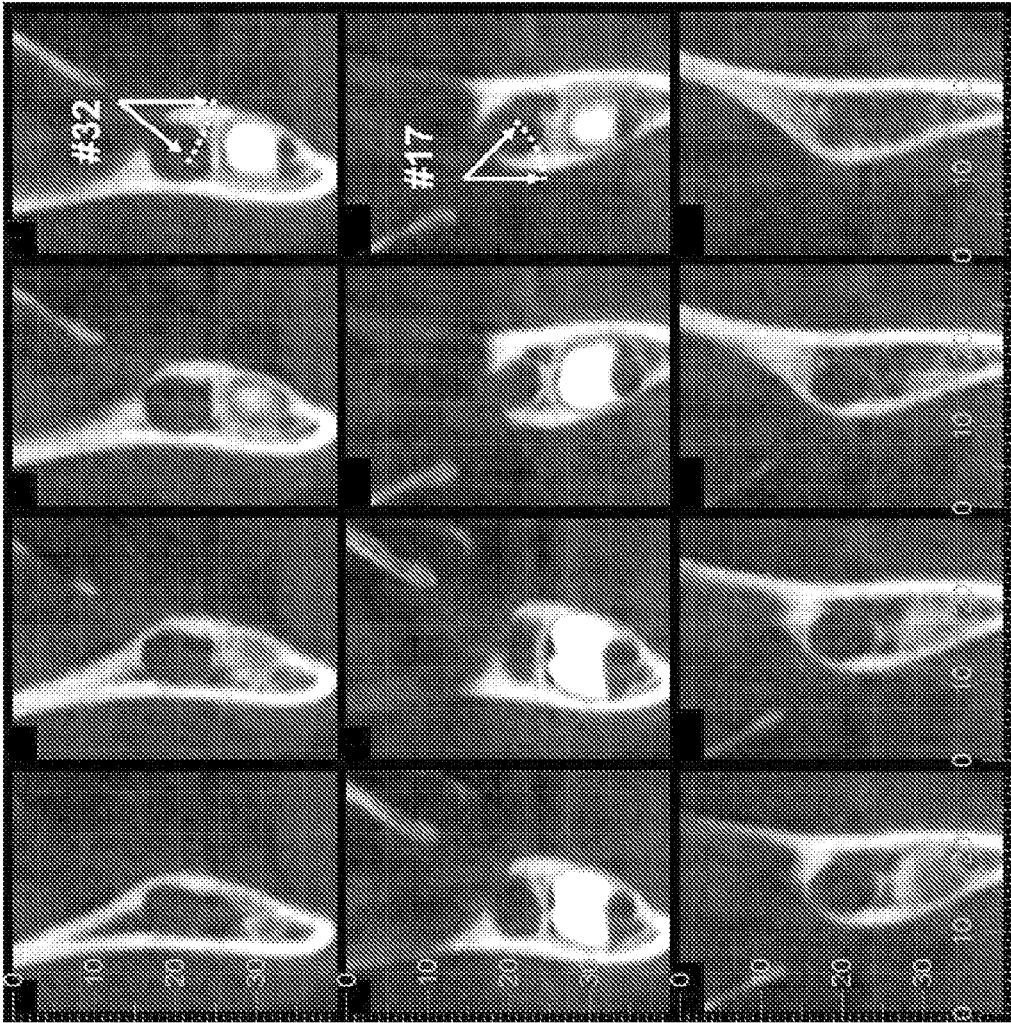

FIG. 21

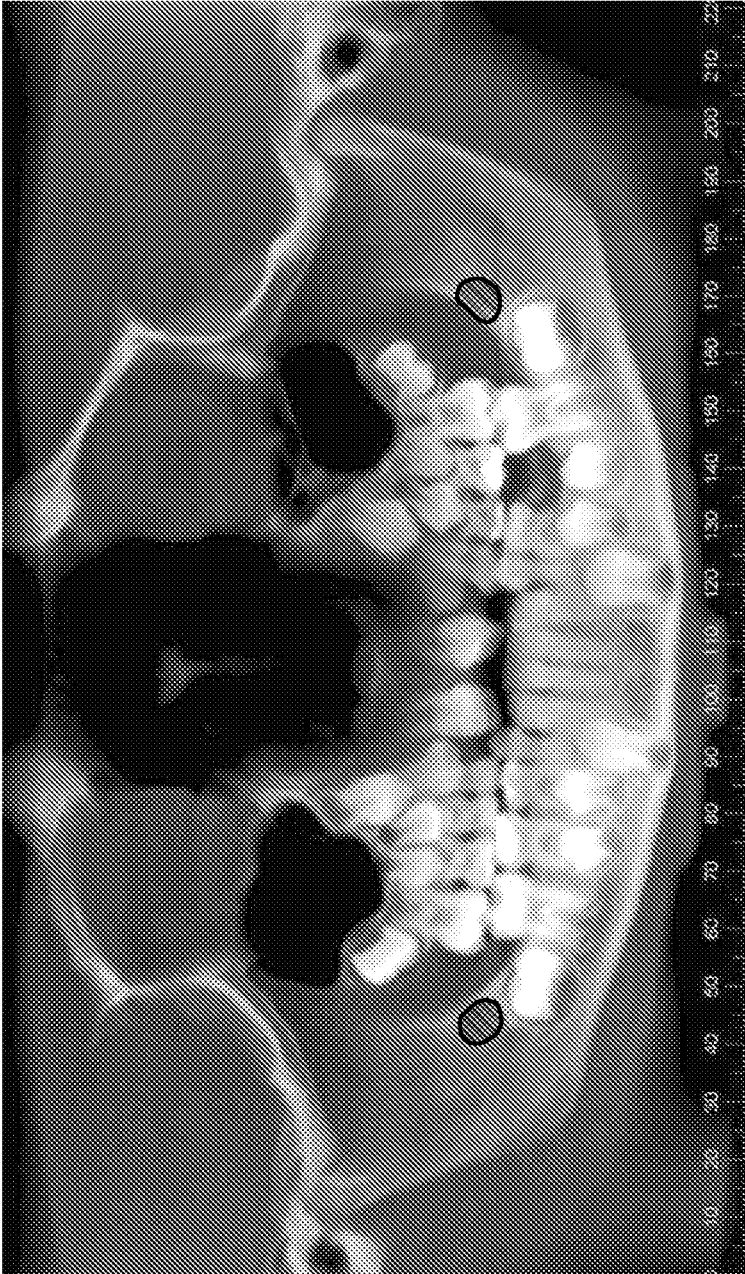

FIG. 22

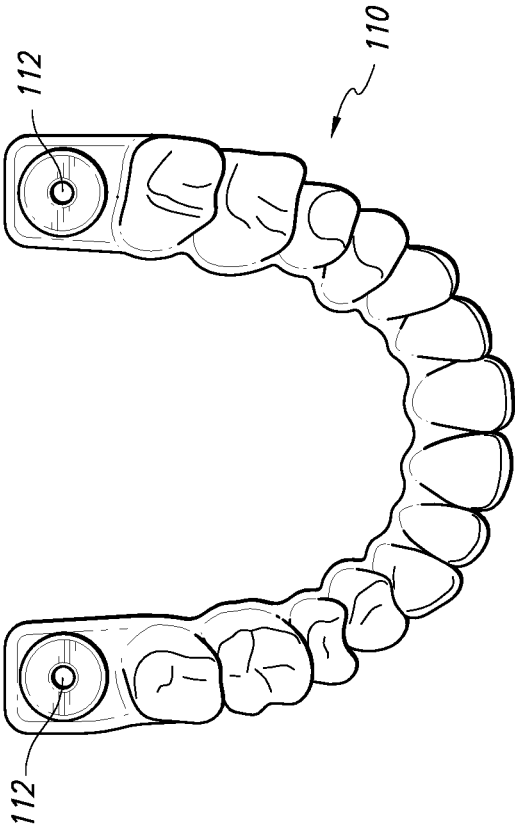

FIG. 23

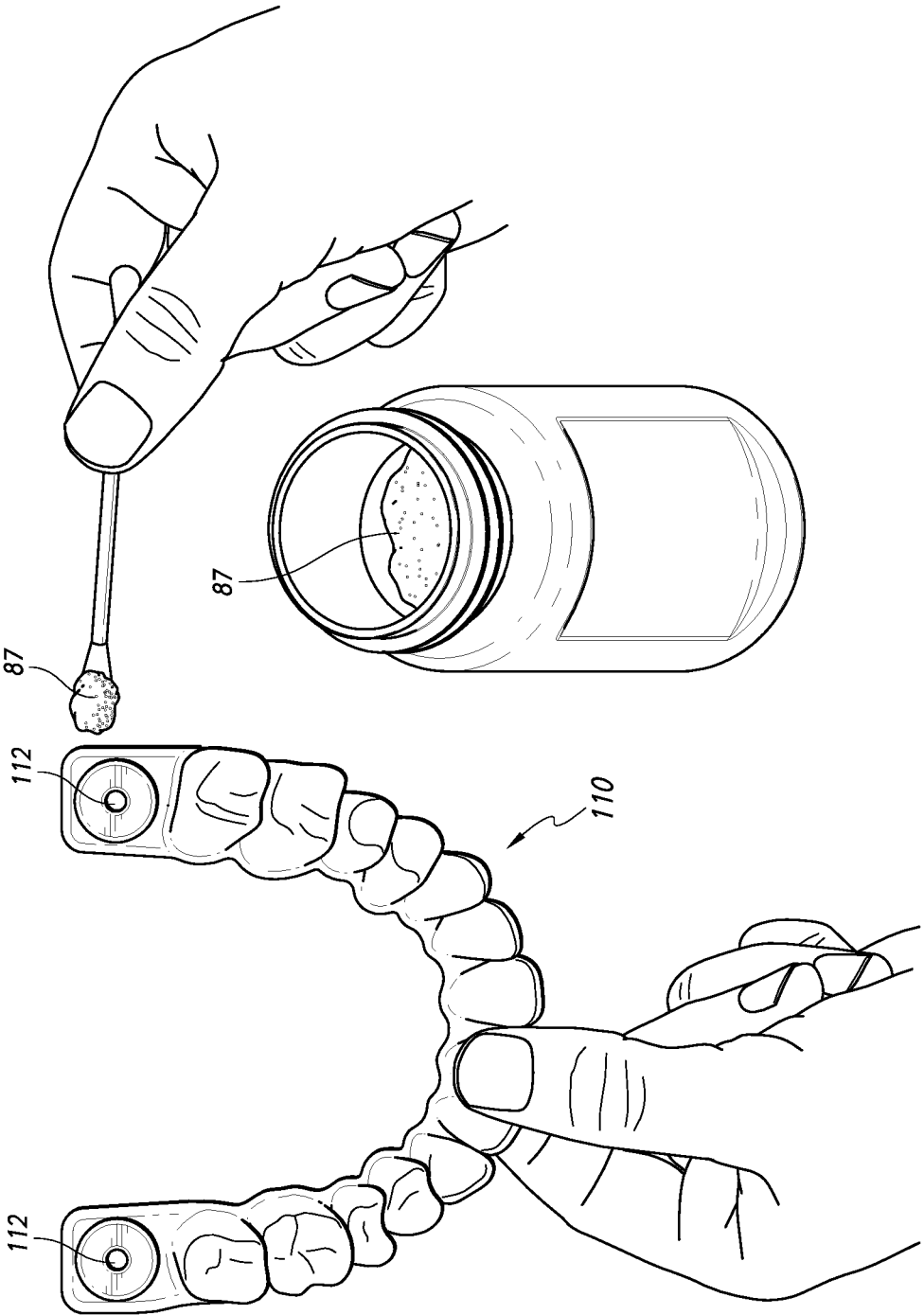

FIG. 24

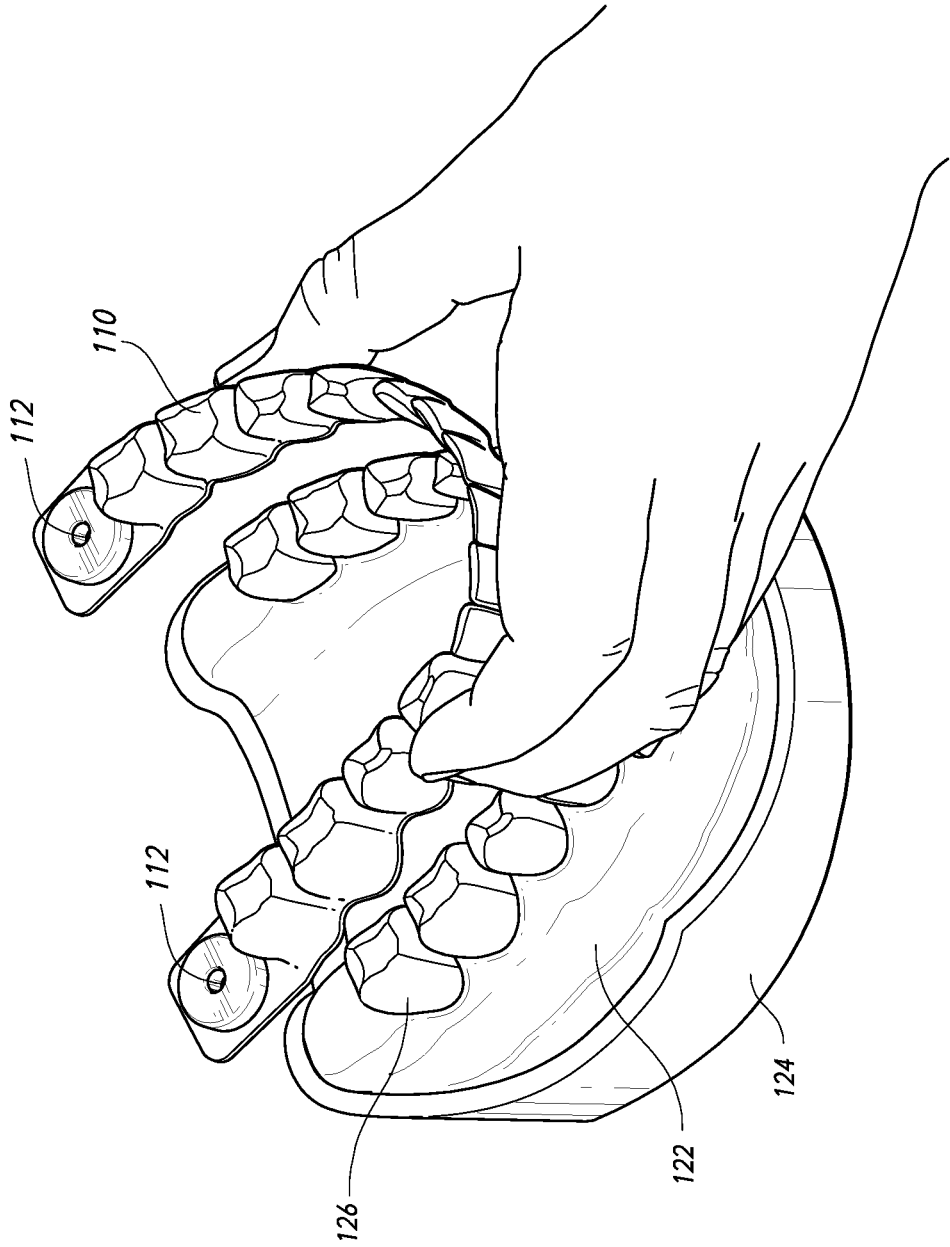

FIG. 25

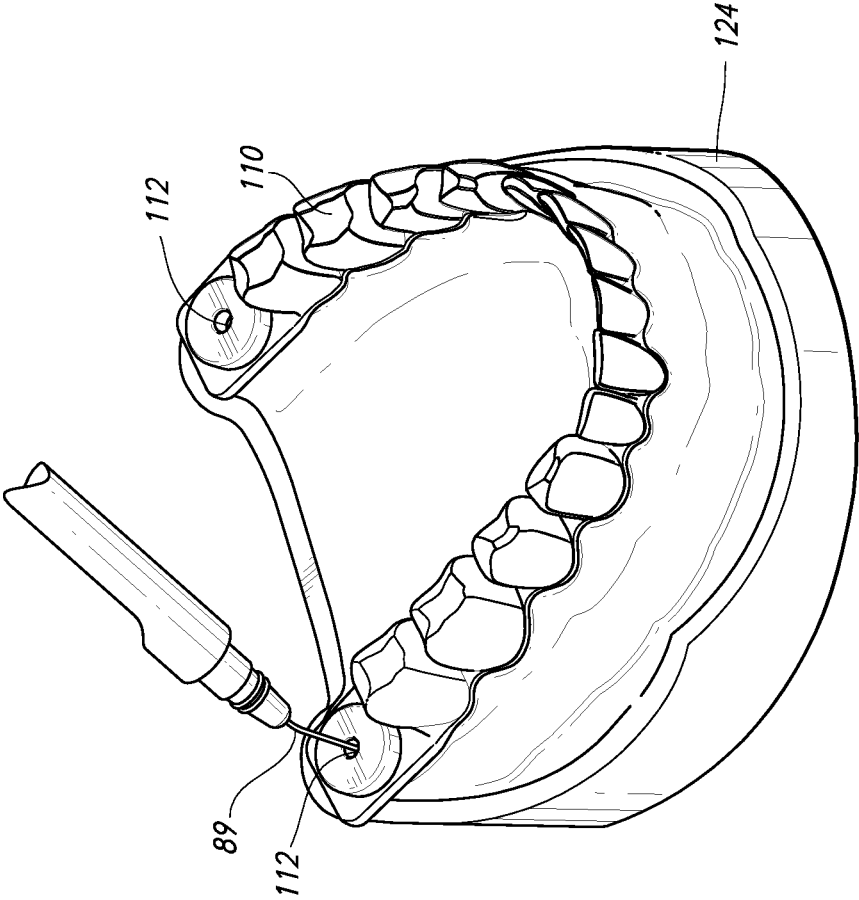

FIG. 26

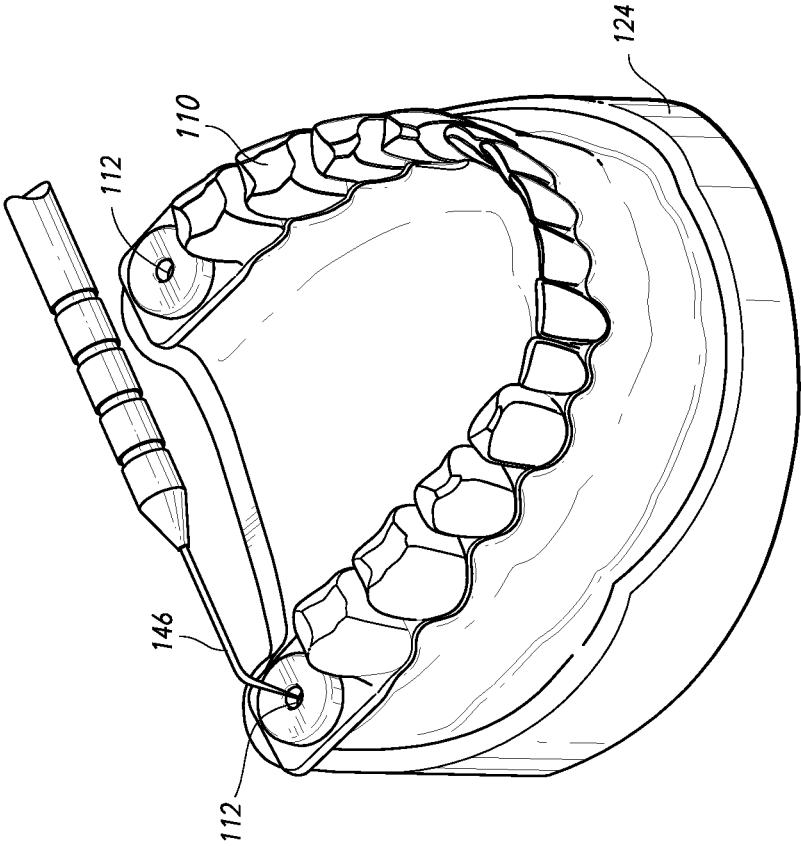

FIG. 27

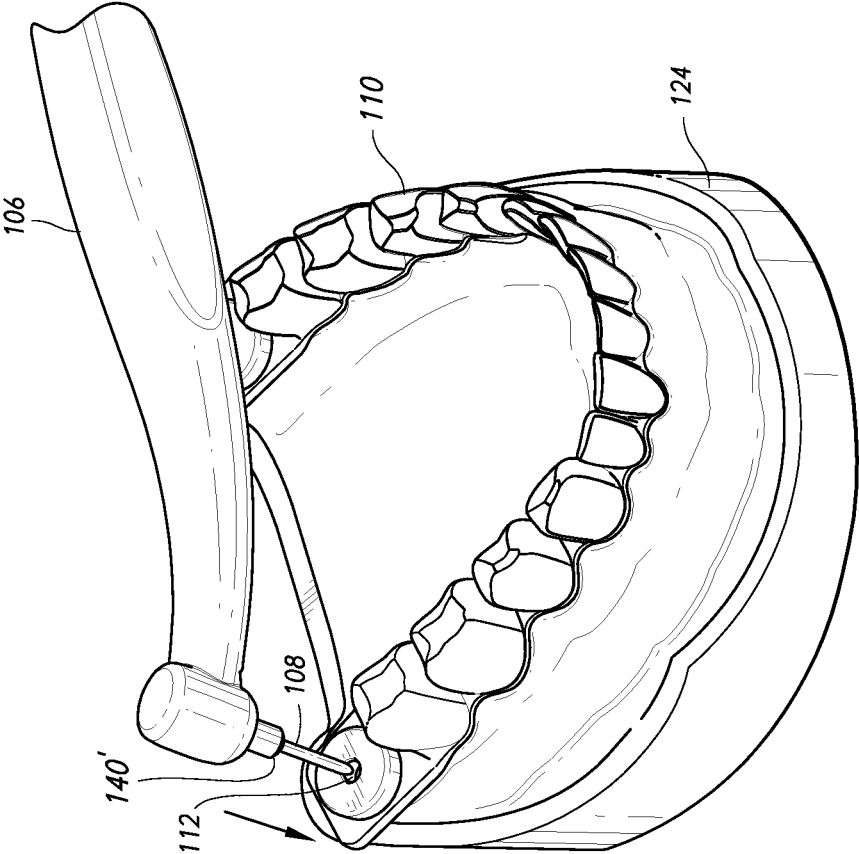

FIG. 28

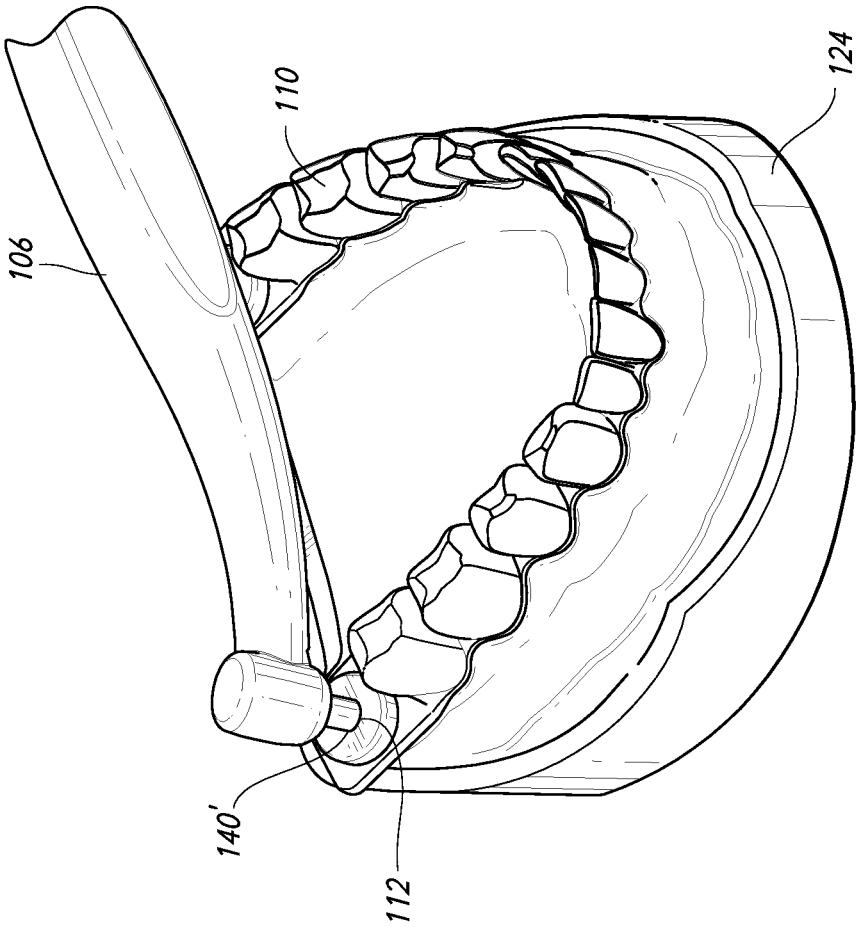

FIG. 29

1

THERAPEUTIC TOOTH BUD ABLATION

The present application is an application claiming the benefit under 35 USC Section 119(e) of U.S. Provisional Patent Application Ser. No. 61/177,143, filed May 11, 2009. The present application is based on and claims priority from this application, the disclosure of which is hereby expressly incorporated herein by reference in its entirety.

COPYRIGHT NOTICE

A portion of the disclosure of this patent document contains material that is subject to copyright protection. The copyright owner has no objection to the facsimile reproduction of the patent disclosure as it appears in the Patent and Trademark Office patent files or records, but otherwise reserves all copyright rights whatsoever.

TECHNICAL FIELD

Described herein are a tooth bud ablation (TBA) procedure and a tooth bud ablation (TBA) system.

BACKGROUND ART

Approximately 3.5% of the total \$100 billion spent on dental care in the United States in 2008 was for traditional surgical removal of third molars (i.e. “wisdom teeth” extractions), including the associated costs of imaging, sedation, and resulting complications. Traditional surgical removal of third molars, however, is a highly invasive, painful, and complication-ridden procedure. Further, third molar extraction represents the only procedure in the United States and Europe where it is considered “normal” to subject patients of any age group to such a highly invasive prophylactic surgery that carries significant life-long risks for the excision of asymptotic or non-pathologic tissue. Dental practitioners (e.g. general dentists, pediatric dentists, and oral surgeons) have been trained to remove children’s wisdom teeth (third molars) before the wisdom teeth cause problems . . . but this surgery carries significant pain, risks and costs.

The main problem associated with third molar tooth extractions—aside from the pain inflicted—is the serious risk of complications associated with such an invasive procedure. Each year “more than 11 million patient days of ‘standard discomfort or disability’—pain, swelling, bruising, and malaise—result post-operatively, and more than 11,000 people suffer permanent paresthesia—numbness of the lip, tongue, and cheek—as a consequence of nerve injury during the surgery. At least two thirds of these extractions, associated costs, and injuries are unnecessary, constituting a silent epidemic of iatrogenic injury that afflicts tens of thousands of people with lifelong discomfort and disability.”

If you interview people under the age of 40 and ask them what has been the most invasive surgical procedure they have personally experienced (that is not trauma related), there is a greater than 90% chance that it will be their “wisdom teeth” extraction. The current standard of care in America for “managing” third molars (e.g., “wisdom teeth”) in adolescents and young adults is generally to have all four third molars extracted once they are formed, unless it is absolutely clear that these teeth will erupt normally. General dentists and oral surgeons alike are complicit in their belief that third molars generally should be extracted because not all will erupt normally, thus causing future pathology.

Each year, an estimated 10 million third molar tooth extractions account for over 92% of all teeth extracted for patients

2

under the age of 40. This represents surgery on approximately 5 million people each year at an estimated cost of over \$2.5 billion for third molar extraction fees alone in the United States. When IV sedation fees, X-ray imaging expenses, post-op medications and unplanned post-operative expenses associated with treating complications are added in, the true United States health care cost is estimated to be well over \$3.5 billion. In addition to fee inflation, it has been shown that “upcoding” of wisdom teeth extraction (i.e. using an insurance code for payment of a higher fee than is clinically justified) has become an increasing problem for insurers. Insurance claims patterns clearly show that this procedure is largely treated as an elective procedure. The average annual income per oral surgeon has been estimated to be approximately \$500,000 for third molar extraction fees alone. Insurance companies have historically reported that reimbursement for third molar extractions has been the highest reimbursed surgical procedure—even higher than hysterectomies in years when medical insurance used to pay for both procedures.

The market demographics and associated expenses are compelling. Over 77% of children at age 6 have all four third molar tooth buds radiographically detectable on routine panoramic X-rays (a type of volume scan). Over 90% of all teenagers in the United States have at least one third molar that will fully form. A typical cost for an oral surgeon to remove all four third molars on a teenager is generally \$2,000 to \$2,500 per patient once the teeth have at least partially formed—but before they have erupted—including the cost of IV sedation, consultations, and X-ray imaging costs.

There has been considerable controversy for the past fifty years regarding prophylactic extraction of third molars. A number of leading authorities have objectively tried to demonstrate that prophylactic extraction is a waste of healthcare dollars, citing studies that indicate there is no objective scientific evidence for such a procedure, while other groups vigorously argue that prophylactic extraction in the teens and early adult years greatly eliminates more serious problems later in life and is worth the cost and risk.

An important question to ask is, “What happens if no prophylactic third molar extractions occur?” For instance, “as many as 22% of all emergency department visits” at a United States military support facility were related to dental problems, most of which were third-molar specific. In third-world countries, where prophylactic extraction of wisdom teeth is simply not performed, a high percentage of patients will present with acute infections, decay, gum disease and other problems later in life. In Jordan—where prophylactic extraction is not performed—46% of adult patients had pathology (decay, infection, bone loss, etc.) detectable on their third molars on routine X-rays and volume scans. Numerous studies show that third molars are hard to clean, generally do not erupt fully, and are the single most-likely teeth to have problems associated with them.

Routine panoramic X-rays of adults taken during a random two-week period are shown in FIGS. 1 and 2. These X-rays show the examples of the range of problems that adult patients experience when they have third molars that are not extracted at an early age, including advanced decay and gum infections. For example, FIG. 1 shows a 48-year-old patient with both upper third molars present. There is a gum infection around both third molars that has caused 90% of the bone on the distal side of the second molars to be destroyed. In order to save the first molars, extraction of the second and third molars on the upper arch will be necessary. FIG. 2 shows another example in which a 36-year-old patient has all four third molars present. The upper third molars are hyper-erupt-

ing because they have no opposing teeth to occlude against. They will eventually need to be extracted. The lower third molars are horizontally impacted and show no signs of infection, but if they become infected, then the patient will almost certainly lose the adjacent second molars because of the bone damage that will occur.

The problem all practitioners face is that it is practically impossible to tell in advance which impacted wisdom teeth will ultimately cause future pathology. The reality is that most wisdom teeth (well over 50%) are surgically extracted prophylactically with no real knowledge that they will actually cause future pathology.

If pathology appears in patients over the age of 40, however, the stakes are much different. According to two prospective studies in the United States, in 1997 10.5% and in 2002 17.3% of patients requiring third molar extractions were over the age of 40. If a patient is presenting later in life to have one or more third molar extracted, it is because active pathology has been diagnosed, making surgery no longer elective. The attendant complication rates are not just higher, but these patients were categorized as “very high risk patients” for surgery. These studies concluded, “[t]he risk to patients and to the profession can be dramatically reduced by considering early removal of abnormal third molars” and “based on our experience, we propose extraction of third molars during adolescence when the X-ray indicates normal eruption cannot be expected due to lack of space or an abnormal position.”

The occurrence of post-operative complications is generally considered to be over 15% by most independent researchers. For instance, the formation of long-term periodontal pockets on the distal surfaces of second molars that results in gum disease, infection and eventual second molar tooth loss is estimated to be over 10% due to the damage and poor bone morphology that result from third molar extraction surgery. The incidence of post-operative infections and “dry sockets” is generally accepted to be over 15%. Temporary parasthesia due to damage to the mandibular nerve or the lingual nerve is over 10%, with residual permanent numbness of the lip or tongue present in approximately 1.5% of all patients. Recently, it has been concluded that approximately 23% of all cases of long-term Temporal Mandibular Joint (“TMJ”) dysfunction and chronic joint pain are attributable to third molar extraction surgeries.

Malpractice claims against dental practitioners relating to third molar extractions are at an all time high. Litigation for residual TMJ problems is increasing; in 2002 a North Carolina jury awarded \$5 million in damages to a patient with TMJ pain following third molar extractions. The incidence of litigation over permanent numbness of the lip has dramatically increased in recent years. Malpractice claims with resulting payouts have been reported to be as high as two-thirds of all claims made against dental practitioners when nerve damage is involved.

If the wisdom teeth are not extracted in adolescence, the roots will fully form, making future extraction difficult and dramatically increasing the incidence of serious complications if surgery should later be required. The damage induced by long-standing, chronic infections in adults may necessitate the extraction not only of the third molars when they become symptomatic, but also of the adjacent second molars. Additional complications include the reduced healing response of adults as compared to adolescents, and the economic hardship induced by having to miss work. Many references indicate that prophylactic extraction of third molars in teens and young adults—in spite of the possibility of life-long complications such as nerve damage—is justified to avoid the non-elective third molar extraction in adults over the age of 30.

Complications can be severe, even requiring hospitalization when teeth have been extracted on an out-patient basis. There have even been reports of patients who died as a direct result of wisdom tooth extractions.

As an example, FIG. 3 is an X-ray showing a 9-year-old patient with four third molar tooth buds present; three of them are in very early stages of enamel formation. The lower right third molar tooth bud does not have enamel formed yet, but will shortly. This X-ray shows an example of the early stages in which the tiny third molar tooth buds begin to form, begin to develop enamel, and finally begin to develop roots. Early signs of problems are almost always clearly evident by the time a patient is a teenager.

Once the tooth starts to form, the tooth bud starts to become encased in bone and appears to be “pushed down” into the mandible and maxilla as the child’s jaw bone grows out and around the tooth bud with age. Future surgical access becomes far more invasive as the bone encases the forming third molar. Given the basic physiology involved, early intervention is the only approach that will eliminate the complications and high costs associated with extraction of fully formed third molars later in life.

The idea of prophylactic third molar tooth bud removal is not new. In 1936, Dr. Henry supported the surgical enucleation of tooth buds, and it was again supported in the mid 70s by several practitioners using somewhat invasive surgical techniques to physically access the tooth buds and mechanically cut them out. In 1979, Drs. Gordon and Laskin used cryoprobes to enucleate third molar tooth buds in dogs. However, at the NIH Conference On Third Molars in 1979 it was concluded that “[a]lthough there are cogent reasons for early removal of third molars, the group felt that the suggested practice of enucleation of third molar tooth buds, based on predictive studies at age 7 to 9, is not currently acceptable.” (National Institutes of Health—*Removal Of Third Molars Consensus Development Conference Statement*—1979.)

Early removal of partially formed third molars (sometimes referred to as a “germectomy”) where the enamel of the crown has completely formed but less than one-third of the root length has formed, is demonstrated to be somewhat less invasive and carries no demonstrated long-term complications or risks associated with early-stage surgery. However, it is still highly invasive and generally requires IV sedation of the teenage patient. The American Association of Oral & Maxillofacial Surgeon’s *White Paper On third Molar Data* references five studies involving over 1,100 germectomies with not a single case of a long-term complication (nerve injury, etc.) associated with the surgery. Further, since the germectomies were carried out on teenagers, there were no economic hardships induced by missing work. The *White Paper* understates the obvious conclusions associated with early intervention: “It does appear that early third molar removal may be associated with a lower incidence of morbidity and also less economic hardship from time off work for the patient.” However, it can also be concluded that there is a tremendous conflict of interest because this paper was written by oral surgeons. To date there is still no measurable shift by dental practitioners to change the way in which third molars are screened, diagnosed, and extracted (i.e., early extraction), indicating that there is a need to fundamentally change the way this condition is being surgically managed.

There are a number of existing alternative technical approaches that can be considered for prophylactic enucleation of third molar tooth buds before the crown or root begins formation in children age 6 to 10. These technical approaches include ablation procedures using different types of ablation means. Exemplary ablation procedures include electrosurge

5

tissue ablation (rats), cryoablation (dogs), laser ablation (dogs), and the use of a scalpel (humans). All but the first three ablation procedures (microwave ablation, radio frequency ablation, and irreversible electroporation) have significant limitations due to being highly invasive, high in cost, requiring cumbersome equipment, or due to the limited means of mechanical access in the oral cavity. Nor do these ablation procedures offer the potential for real-time feedback control to contain collateral tissue damage. To date, the only documented trial of any form of tooth bud ablation procedure utilizing ablation technology that is currently used in mainstream medicine is cryoablation (although preliminary animal trials have been completed using electrosurgical power and lasers).

The article entitled "Selectively Preventing Development Of Third Molars In Rats Using Electrosurgical Energy" by Silvestri et al. describes a pilot study that tests the hypothesis that third molars can be selectively prevented from developing. To test the hypothesis, a study was conducted in which thirty-three neonate rats received electrosurgical energy to the mucosal surfaces of one of their maxillary tuberosities. In this study, guides (insulating plastic positioning devices that housed the electrosurgical probes) were used. The guides were fabricated using the mouths of euthanized rat pups of the same age as the rats that were to be treated as a mold for creating the guides. Then, the electrosurgical probe placed so that its stainless steel tip extended less than 1.0 mm beyond the plastic positioning device to ensure contact with the external surface of the oral mucosa of the maxillary tuberosity. Finally, when in position, the rat pups received a single, unilateral, momentary pulse of monopolar electrosurgical energy to the external surface of the gum tissue of their maxillary tuberosity regions. It should be emphasized that this surface application of electrosurgical energy acted first to unnecessarily kill the overlying gum tissue, then bore a hole through the gum tissue, and otherwise damage not only the tooth buds, but other nearby tissue. The rats were cared for, but after the experimental period, were euthanized to determine the effectiveness of the procedure. The results were that ten rats showed no intra-oral or radiographic evidence of third molar development (and most of these rats subsequently developed palatal deformities), and six developed smaller-than-normal third molars. The conclusion was that maxillary third molars could be selectively prevented from developing in rat pups at or near the time of tooth bud initiation. It was recognized, however, that electrosurgical energy was too powerful and uncontrollable to reliably confine its damage to only the tooth-forming tissues.

SUMMARY OF THE INVENTION

Described herein is a tooth bud ablation procedure that results in tooth agenesis, including the steps of: (a) physically seating a custom surgical stent having at least one surgical guide so the at least one surgical guide corresponds to at least one tooth bud surgical site; (b) using the at least one surgical guide, making a surgical access path at the at least one tooth bud surgical site; (c) using the at least one surgical guide, guiding placement of an ablation probe tip having a center of ablation so that the center of ablation is in the middle of a tooth bud at the at least one tooth bud surgical site; and (d) at least partially ablating at least one tooth bud.

Described herein is a tooth bud ablation system for use in a tooth bud ablation procedure that results in tooth agenesis, the system including: (a) a custom surgical stent with at least one surgical guide corresponding to at least one tooth bud surgical site; (b) an ablation probe tip having a center of ablation; and

6

(c) the at least one surgical guide having structure for guiding placement of the ablation probe tip so that the center of ablation is in the middle of a tooth bud by inserting the ablation probe tip through the at least one surgical guide.

Described herein is an ablation procedure including the steps of: (a) physically seating a custom surgical stent having at least one surgical guide so the at least one surgical guide corresponds to at least one lesion or tumor surgical site; (b) using the at least one surgical guide, making a surgical access path at the at least one lesion or tumor surgical site; (c) using the at least one surgical guide, guiding placement of an ablation probe tip having a center of ablation so that the center of ablation is in the middle of a lesion or tumor at the at least one lesion or tumor surgical site; and (d) at least partially ablating at least one lesion or tumor.

Described herein is an ablation procedure including the steps of: (a) physically seating a custom surgical stent having at least one surgical guide so the at least one surgical guide corresponds to at least one lesion or tumor surgical site; (b) using the at least one surgical guide, guiding placement of an ablation probe tip having a center of ablation so that the center of ablation is in the middle of a lesion or tumor at the at least one lesion or tumor surgical site; and (c) at least partially ablating at least one lesion or tumor.

Described herein is a method for volume scanning both hard tissues and soft tissues of a patient, the method including the steps of: (a) using an impression of a material visible in a volume scan; (b) generating a volume scan in which hard tissue is visible and the impression is visible, and soft tissue being "visible" as the space between the visible hard tissue and the visible impression; and (c) providing results of the step of generating a volume scan for the purpose of manufacturing or fabricating a custom surgical stent having at least one surgical guide for guiding placement of an ablation probe tip.

Described herein is a method for simultaneous volume scanning of both hard tissues and soft tissues, the method including the steps of: (a) using a dental impression of a material visible in a volume scan; (b) physically seating the dental impression in a patient's mouth; (c) volume scanning the patient's mouth while the dental impression is seated therein; (d) the step of volume scanning generating a volume scan in which hard tissue is visible and the dental impression is visible, and soft tissue is "visible" as the space between the visible hard tissue and the visible dental impression; and (e) providing the results of the step of volume scanning for the purpose of manufacturing or fabricating a custom surgical stent having at least one surgical guide for guiding placement of an ablation probe tip.

Described herein is a method for manufacturing or fabricating a custom surgical stent, the method including the steps of: (a) using a volume scan image in which hard tissue is visible and a dental impression is visible, and soft tissue is "visible" as the space between the visible hard tissue and the visible dental impression; and (b) manufacturing or fabricating a custom surgical stent with at least one ablation probe tip guide for guiding at least one ablation probe tip to a pre-defined angle and depth of ablation based on information obtained from the volume scan image.

Described herein is a tooth bud ablation procedure that results in tooth agenesis, including the steps of: (a) pre-operatively taking measurements to determine a three-dimensional location of the middle of a tooth bud; (b) placing an ablation probe tip having a center of ablation so that the center of ablation is in the three-dimensional location of the middle of a tooth bud; and (c) at least partially ablating at least one tooth bud.

Described herein is a custom surgical stent for use in a tooth bud ablation procedure that results in tooth agenesis, the custom surgical stent for use with an ablation probe tip having a center of ablation, the stent including: (a) a custom surgical stent with at least one surgical guide corresponding to at least one tooth bud surgical site; (b) the at least one surgical guide having guiding structure to guide placement of an ablation probe tip at a pre-defined angle so that a center of ablation of the ablation probe tip is in the middle of a tooth bud; and (c) the at least one surgical guide having mechanical stop structure to limit the depth of the ablation probe tip to a pre-defined depth.

The foregoing and other objectives, features, and advantages of the invention will be more readily understood upon consideration of the following detailed description of the invention, taken in conjunction with the accompanying drawings.

BRIEF DESCRIPTION OF THE DRAWINGS

The accompanying drawings are incorporated in and constitute a part of this specification.

FIG. 1 is an X-ray showing a 48-year-old patient with both upper third molars present, the X-ray being presented to show examples of the range of problems that adult patients experience when they have third molars that are not extracted at an early age.

FIG. 2 is an X-ray showing a 36-year-old patient with all four third molars present, the X-ray being presented to show examples of the range of problems that adult patients experience when they have third molars that are not extracted at an early age.

FIG. 3 is an X-ray showing a 9-year-old patient with four third molar tooth buds present; three of them are in very early stages of enamel formation, but the lower right third molar tooth bud does not yet have enamel formed.

FIG. 4 is a flow chart showing steps in preferred TBA procedures including: (1) routine screening and diagnosis; (2) pre-surgical impressions and scanning; (3) assembling a TBA surgical kit; (4) operator delivery of the TBA procedure; and (5) follow-up.

FIG. 5 is a simplified block diagram of a TBA probe system, a custom surgical stent, and a tooth bud.

FIG. 6 is a cross-sectional side view of an ablation probe tip in the process of being inserted through a surgical guide of a stent.

FIG. 7 is a cross-sectional side view of an ablation probe tip inserted through a surgical guide of a stent into the tooth bud.

FIG. 8 is a cross-sectional side view of an ablation probe tip having a linear array of temperature sensors inserted in the tooth bud.

FIG. 9 is a cross-sectional side view of an ablation probe tip ablating the tooth bud.

FIG. 10 is a cross-sectional side view of an ablation probe tip being removed from the ablated tooth bud.

FIG. 11 is a flow chart showing the steps of a TBA procedure that results result in tooth agenesis.

FIG. 12 is a flowchart showing the steps that a software program for manufacturing or fabricating custom surgical stents 110 and defining (and/or computing or calculating) the pre-determined parameter settings and/or treatment time settings.

FIG. 13 is a panoramic X-ray showing a patient whose third molar tooth buds in the #17 and #32 positions are treatable by TBA.

FIG. 14 is a pre-operative cone beam computed tomography ("CBCT") scan of a different patient.

FIG. 15 is a series of X-rays showing successive 1.0 mm slices through both #17 and #32 in 1.0 mm increments.

FIG. 16 is a perspective view from a front corner showing a pre-operative upper-arch impression being taken of a simulated patient.

FIG. 17 is a cross-sectional view of an upper-arch impression being taken of a simulated patient.

FIG. 18 is a perspective view from above of the completed upper-arch impression.

FIG. 19 is a perspective view from above of the completed upper-arch impression, along with a stone model that will serve as a "positive" for manufacturing or fabricating of a custom surgical stent for that patient's upper-arch.

FIG. 20 is a CBCT scan with notations showing the measurement of the angle of entry into the tooth bud.

FIG. 21 is a series of X-rays with notations showing the measurement of the lateral angle of entry.

FIG. 22 is a CBCT scan with highlights showing the computed volume of each tooth bud.

FIG. 23 is a perspective view from above of a surgical stent with two surgical guides, the stent having been manufactured or fabricated using the CBCT positioning information.

FIG. 24 is a perspective view showing topical anesthetic being applied to the base of the surgical guide.

FIG. 25 is perspective view from a front corner of a surgical stent being seated on the upper arch of the simulated patient.

FIG. 26 is a perspective view from a front corner of a local anesthetic being injected into a tooth bud site.

FIG. 27 is a perspective view from a front corner of a tissue trocar being used to punch to the base of a tooth bud.

FIG. 28 is a perspective view from a front corner of an ablation probe tip with a mechanical (physical) stop being positioned through the surgical guide into the tooth bud.

FIG. 29 is a perspective view from a front corner of the ablation probe tip being positioned in each tooth bud through the surgical guide so that the ablation probe tip's effective center of ablation is in the middle of each tooth bud.

DETAILED DESCRIPTION OF THE INVENTION

The highly invasive surgical procedure of extracting third molars can be completely eliminated by prophylactically eliminating the small tooth buds that will eventually form the wisdom teeth. Children age 6 to 12 will generally have radiographically detectable tooth buds with no signs of tooth formation inside the tooth bud. Third molar tooth bud agenesis (the lack of third molar formation) can only be conclusively determined by age 14. Third molar tooth buds are lying just 2.0 mm to 3.0 mm beneath the surface of the attached gingival (gum) tissue, making them accessible for rapid anesthesia and minimally invasive ablation with the correct selection of soft tissue ablation and supporting scanning and stent-manufacturing technologies.

By successfully improving existing medical technology, the highly invasive, painful, and complication-ridden procedure of traditional surgical removal of third molars (i.e. "wisdom teeth" extractions) can be replaced with a minimally invasive tooth bud ablation (TBA) procedure 70 such as that shown in FIG. 4 that is risk free, painless post-operatively, and less expensive when compared to surgical extractions.

The TBA procedure 70 (FIG. 4) and TBA system 100 (FIG. 5) for use in the TBA procedure 70 seek to achieve: (1) a minimally invasive procedure consisting of a surgical access path at a surgical site (e.g. at each tooth bud surgical site), (2) that can predictably ablate all four third molar tooth buds 120 in thirty (30) minutes or less (including time to administer anesthesia) using either microwave ("MW") or radio fre-

quency (“RF”) ablation, (3) that can be administered by dental practitioners under normal office conditions, (4) with direct procedure costs reduced by 25% or more, and (5) with zero risks or complications when compared to traditional surgical extraction of fully developed third molars. It should be noted that the TBA procedure 70 is shown and described as a prophylactic third molar tooth bud ablation (TMTBA), but it is not limited thereto. For example, there may be supernumerary teeth that should not be in a patient’s mouth (e.g., there may be two teeth #5), the removal of which would not be prophylactic in nature.

One preferred advantage of the surgical phase 90 described herein is that it is a minimally invasive surgical procedure. With a minimally invasive surgical procedure design coupled with electronic feedback controls using MW and RF ablation technology to limit soft tissue damage, performing this procedure on children aged 6-12 years old takes approximately thirty (30) (or fewer) minutes, including the time to administer local anesthetics.

Another preferred advantage of the surgical phase 90 described herein is that it will not accidentally disrupt adjacent second molar tooth development, even though the formation of second molars are well under way because these tooth buds 120 have started to form before birth. The use of relatively new scanning technologies (e.g. computed tomography volume scanning such as cone beam computed tomography (CBCT) scanning and MRI volume scanning) and accurate custom surgical stents 110 to guide ablation probe tip 108 placement will eliminate the risk of accidentally disrupting the second molars by minimizing collateral tissue damage.

Summarily, the TBA procedure 70 (FIG. 4) preferably includes a screening phase 72, a pre-surgical phase 80 (also referred to as TBA pre-surgical phase 80) that includes pre-surgical scanning 82 and the assembling of a TBA surgical kit 88 (that includes pre-determined settings 105 as well as a surgical stent 110), a surgical phase 90 (also referred to as TBA surgical phase 90), and a follow-up phase 98.

A tooth bud ablation (TBA) system 100 (FIG. 5) is preferably used during the surgical phase 90 (shown graphically in FIGS. 6-10 and as a flow chart in FIG. 11) of the TBA procedure 70. Summarily, the TBA system 100 includes a TBA probe system 101 (including a generator 104 capable of emitting one or more types of ablation means 104’, a hand piece 106, and an ablation probe tip 108) and at least one surgical stent 110 (which was manufactured or fabricated during the pre-surgical phase 80). Each stent 110 has at least one surgical guide 112 to guide the placement of the ablation probe tip 108 so that its center of ablation 130a is placed into the middle of the tooth bud 130b. This is accomplished by positioning ablation probe tip 108 through the surgical guide 112 at a pre-defined angle and depth using a mechanical relationship of the ablation probe tip 108 and the surgical guide 112 to form a “stop” therebetween. FIGS. 6-10 show (and FIG. 11 describes) the procedure of inserting the ablation probe tip 108 through the surgical guide 112 of a stent 110, ablating the tooth bud 120, and removing the ablation probe tip 108 from the ablated tooth bud 120’.

The TBA System 100

The TBA system 100 described herein is the system that is used during the surgical phase 90 of the TBA procedure 70. Some of the components (e.g. the custom surgical stent 110 and the pre-determined settings 105) used in the TBA system 100 are part of the TBA surgical kit assembled during the pre-surgical phase 80.

The TBA system 100, as shown in FIG. 5, includes a TBA probe system 101 (including a generator 104, a hand piece

106, and an ablation probe tip 108) and at least one surgical stent 110 (each stent 110 has at least one surgical guide 112 to guide (direct) the placement of the ablation probe tip 108 to the middle of the tooth bud 130b). The generator 104 and the hand piece 106 may be jointly referred to as the ablation probe unit 102 (or the programmable ablation probe unit 102). The generator 104 and hand piece 106 may be integral or functionally connected together. The generator 104 (and/or the ablation probe unit 102) may be programmed with pre-determined parameter settings 105a and/or treatment time settings 105b (referred to jointly as pre-determined settings 105). The generator 104 (and/or the ablation probe unit 102) provides an ablation means 104’ for ablating the tooth bud 120 based on the pre-determined settings 105. Central to the TBA system 100, is the interaction between the ablation probe tip 108 and the surgical stents 110 (and specifically the surgical guides 112).

Generator 104

The generator 104 provides the ablation means 104’ suitable for ablating a tooth bud 120 during the surgical phase 90 of the TBA procedure 70. MW energy and RF energy are discussed as exemplary preferred ablation means 104’. Another alternative preferred ablation means 104’ is irreversible electroporation because it has subsecond activation times that can reduce collateral tissue damage. Yet another alternative preferred ablation means 104’ include, but are not limited to, cryoablation, ultra-high intensity ultrasound, laser, chemical, thermal or hot tip (e.g. a tip having any source of heat including, but not limited to a light bulb, a soldering iron, or steam heat), and/or mechanical means. These ablation means 104’ may also be combined either simultaneously or consecutively. It should also be noted that other known and yet-to-be-developed ablation means 104’ may also be used. It should be noted that although discussed primarily in terms of MW and RF, unless specifically set forth otherwise, the use of other ablation means 104’ is possible.

The generator 104 (alone or as part of an ablation probe unit 102) may be programmed by the operator and/or at the laboratory and/or factory and may be accomplished automatically or manually. The programming of the generator 104 may include programming at least one pre-determined setting 105.

The following bulleted points are exemplary details and/or features that may be incorporated in preferred generators 104.

- Preferred generators 104 may be multi-use devices designed as 110V counter-top units.

- Preferred generators 104 may be MW/RF generators with output levels determined initially through finite element analysis models or experimentally derived functions that exist for tumor ablation.

- Preferred generators 104 (and/or ablation probe units 102) may have operator input mechanisms (e.g. knobs, dials, key pads, keyboards, I/O interfaces, connections to the internet, or other means for inputting or programming) in which the operator inputs (or allows input of) the pre-determined settings 105.

- Preferred generators 104 (and/or ablation probe units 102) may have output mechanisms (e.g. a display or audio) for providing setting feedback (e.g. calibration cycles and pre-determined settings 105), warning feedback (e.g. to prevent operator mishandling), and intra-operative feedback on the progress of the procedure such as time remaining (e.g. a count down or a series of beeps to alert the operator to procedure completion) and/or temperature (e.g. to alert the operator to overheating).

- Preferred output displays may be digital readout displays (that may be color and/or in a large format) that permit

the operator to easily see feedback intra-operatively from across a standard dental operatory (approximately 6-8 feet viewing distance).

Hand Piece 106

The hand piece 106 is the functional intermediary between the generator 104 and the ablation probe tip 108. The hand piece 106 may be connected substantially at one end to the generator 104. Substantially at the end of the hand piece 106 opposite the generator 104, the other end of the hand piece 106 (the surgical end) is adapted to accept the ablation probe tips 108. The hand piece 106 is preferably detachable from the generator 104 (if they are not an integral unit) and the ablation probe tip 108 is preferably detachable from the hand piece 106.

The following bulleted points are exemplary details and/or features that may be incorporated in preferred hand pieces 106.

Preferred hand pieces 106 preferably hold or secure an ablation probe tip 108 by latching the ablation probe tip 108 into the hand piece head. In some hand pieces 106, the ablation probe tip 108 latches into the hand piece head at an angle (e.g. a 90 degree angle). It should be noted that the terms "latching" and "latch" are used to describe any type of secure fit including, but not limited to clipping, snapping, or holding.

Preferred hand pieces 106 preferably have a hand piece head (attached or integral) that is at an approximately 20 degree angle to the rest of the hand piece. This bend emulates a standard dental high-speed hand piece to facilitate easy access of both upper and lower surgical sites. In some preferred hand pieces 106, the 20 degree bend can be adjusted intra-operatively to permit improved operator access to both upper and lower arches.

Preferred hand pieces 106 preferably are rapidly detachable from the generator 104. Preferably the connectors are ultra-reliable for repeated removal/attachment from the generator 104.

Preferred hand pieces 106 are preferably fully steam autoclavable. Alternative preferred hand pieces 106 are disposable or have disposable covers.

Preferred hand pieces 106 preferably have actuators to allow operator activation. The actuators may be separate from the hand pieces 106 or integral therewith. Exemplary actuators include, but are not limited to a wireless foot control or a hand-operated switch on the hand piece 106.

The hand piece 106 may be integral with the generator 104 to form a hand-held integrated generator unit (hand-held integrated ablation probe unit).

Ablation Probe Tip 108

One end of the ablation probe tip 108 has structure suitable for connecting it to the hand piece 106. The ablation means 104' flows from the generator 104 through the ablation probe tip 108 and out to a center of ablation 130a (the focal point of the ablation). The ablation probe tip 108 is insertable through the surgical guide 112, through the gingival tissue 122, and into the middle of the tooth bud 130b. The center of ablation 130a is at the insertion end of the ablation probe tip 108 such that when the insertion end of the ablation probe tip 108 is positioned at the pre-defined angle (ϕ) and pre-defined depth (x) during the surgical phase 80, the center of ablation 130a substantially coincides with or overlaps the middle of the tooth bud 130b.

The pre-defined angle (ϕ) is the angle at which the ablation probe tip's effective center of ablation 130a is in the "middle" of the tooth bud 130b as calculated (during the pre-surgical

phase 80) as described herein or using an alternative method. The pre-defined depth (x) is the depth at which the ablation probe tip's effective center of ablation 130a is in the "middle" of the tooth bud 130b as calculated as described herein or using an alternative method. The phrase "middle of the tooth bud 130b" is meant to include the three-dimensional area within the tooth bud 120 and, in particular, the three-dimensional area within the tooth bud 120 that is more towards the absolute middle point than towards the outer periphery of the tooth. The pre-defined angle (ϕ) and pre-defined depth (x) can also be referred to as the "calculated angle and depth," the "prescribed angle and depth," the "proper angle and depth," the "correct angle and depth," the "optimal angle and depth," or the "ideal angle and depth."

The ablation probe tip 108 includes a mechanical stop structure 140 (e.g. a band, protrusion, or shoulder) designed to physically limit the depth of the ablation probe tip 108 when used in conjunction with mechanical stop structure 142 (e.g. the upper surface, a protrusion on the upper surface, or a notch in the upper surface) of the surgical stent 110 and/or surgical guide 112. In other words, the mechanical stop structure 142 of the surgical guide 112 and the mechanical stop structure 140 of the ablation probe tip 108 together limit how much of the ablation probe tip 108 can pass through the surgical guide 112 until there is a mechanical stop between the mechanical stop structure 142 of the surgical guide 112 and the mechanical stop structure 140 of the ablation probe tip 108.

Each ablation probe tip 108 may be individually custom made (e.g. manufactured or fabricated) or may be selected from a family of ablation probe tips 108 (i.e. there may be a "family" of probe tips 108 that will cover all clinical possibilities for tooth bud diameters and depths). In the manufacturing or fabricating of the surgical stents 110, however, the characteristics of the ablation probe tip 108 (custom made or selected) that may be taken into consideration include, for example, length, shape, angle, position of a mechanical stop structure 140, diameter, and size, shape, and location of the center of ablation 130a. For example, if a particular ablation probe tip 108 had mechanical stop structure 140 (shown as the bottom surface of an annular ring or shoulder in FIGS. 6-10 and 28-29) is 10.0 mm from the absolute tip of the ablation probe tip 108 (and the center of ablation 130a is substantially adjacent to the absolute tip), but the center of ablation 130a was only 8.0 mm from the surface of the gingival tissue 122 (shown as (x) in FIG. 6), then the surgical guide 112 would have to be 2.0 mm thick (shown as (y) in FIG. 6). On the other hand, if all surgical guides 112 being made by the procedure were exactly 0.5 mm thick, the ablation probe tip 108 would either have to be made or selected so that the mechanical stop structure 140 is 2.5 mm from the center of ablation 130a of the ablation probe tip 108. The appropriate ablation probe tip 108 preferably will result in the intra-operative placement of the effective center of ablation 130a of the ablation probe tip 108 into the targeted middle of the tooth bud 130b ± 0.5 mm.

The ablation probe tips 108 may be sharp enough and/or may be strong enough to so that the ablation probe tips 108 can be "self-introducing" in that the ablation probe tips 108 can be pushed through the gingival tissue 122. Alternatively, if tissue trocars 146 (described herein) are to be used, the ablation probe tips 108 would not have to be as sharp and/or strong.

The following bulleted points are exemplary details and/or features that may be incorporated in preferred ablation probe tips 108.

Preferred ablation probe tips 108 are preferably disposable (e.g. single-use).

13

Preferred ablation probe tips **108** may be specially designed to work with the specific ablation means **104'** produced by the generator **104**. Other preferred ablation probe tips **108** may be designed to work with multiple types of ablation means **104'** produced by the generator **104** or generators **104**.

The design of the ablation probe tip **108** may be dependent on the physics involved with transmitting ablation means **104'** through the smallest possible diameter with an ideal maximum diameter. For example, an MW/RF ablation probe tip may be designed for transmitting MW/RF energy through the smallest possible diameter with an ideal maximum diameter of 0.5 mm to 1.0 mm targeted.

The "family" of probe tips **108** may include probe tips **108** having a variety of characteristics. For example, the family might have probe tips **108** of different lengths ranging from 5.0 mm to 20.0 mm. This range would accommodate the various diameters of the tooth buds **120** and overlying gingival tissue **122** thicknesses.

Intra-operative temperature sensing (shown as being performed by a linear array of temperature sensors **144** in FIG. **8**) is preferably provided at or near the apex of the ablation probe tip **108** (assuming placement in the ideal middle of the tooth bud **130b**) and/or along the shaft of the probe tip **108**. Temperature sensors **144** provide core temperatures for feedback control purposes (so that the operator can monitor the temperature and/or for software feedback control loops and emergency shutdown) and/or for safety controls to reduce or eliminate collateral tissue damage. Intra-operative tissue temperature is preferably measured, both to assure complete ablation and to prevent over-heating of tissues; this may require additional set up data or programming. If temperature sensors **144** are used, the appropriate ablation probe tip **108** preferably will result in the intra-operative placement of the effective center of ablation **130a** of the ablation probe tip **108** into the targeted middle of the tooth bud **130b**±1.0 mm.

Stent **110**

The at least one custom surgical stent **110** (also referred to as a "stent **110**" or a "surgical stent **110**") has at least one surgical guide **112** (also referred to as "guides **112**" or "ablation probe tip guides **112**"). Two surgical stents **110** would be used, for example, if both upper and lower tooth buds **120** were to be ablated. The surgical stents **110** are designed to seat in a patient's mouth and may be supported by at least one tooth (a tooth-supported surgical stent), soft tissue (a soft tissue-supported surgical stent), and/or bone (a bone-supported surgical stent). If the surgical stent **110** is supported by more than one of these, it could be considered a combination-supported surgical stent. Preferred surgical stents **110** may "snap" into the mechanical undercuts inherent in the patient's erupted teeth. A surgical stent **110** would have more than one surgical guide **112** if more than one tooth bud were to be ablated on either the upper or lower jaw.

The surgical stents **110** and the guides **112** therein are used to control both the pre-defined angle (ϕ) and the pre-defined depth (x) of the ablation probe tip **108** in order to assure that the ablation probe tip's effective center of ablation **130a** is in the middle of the tooth bud **130b**±0.5 mm. The pre-defined angle (ϕ) is primarily controlled by the angle of the surgical guides **112** (the passageways through the stent **110**). The pre-defined depth (x) is primarily controlled by the interaction between the mechanical stop structure **142** of the surgical stent **110** (and/or surgical guide **112**) and the mechanical stop structure **140** of the ablation probe tip **108**. The operator

14

inserts the ablation probe tip **108** at the entry angle (ϕ) defined by the guide **112** and to the depth (x) limited by the mechanical stop structure **140**, **142**.

The surgical guides **112** are passageways through the surgical stent (the passageways being a type of guiding structure). The pre-defined angle (ϕ) for each passageway (guide **112**) is determined by the position of the middle of the tooth bud **130b**. For example, if the middle of the tooth bud **130b** is "slightly forward" the angle (ϕ) of the passageway (guides **112**) would be "slightly forward" so that the ablation probe tip **108** is angled "slightly forward" so that the center of ablation **130a** is positioned substantially at the middle of the tooth bud **130b**. The angle (ϕ) of the passageway is determined (e.g. calculated) by the software based upon tooth bud volumes determined in pre-surgical volume scanning **82**. In addition to providing a path through which the ablation probe tip **108** accesses the gingival tissue and the tooth bud, the guides **110** may also be used to provide access for administering local anesthetic and to provide access to a tissue trocar **146** (if necessary).

In the shown preferred example, the mechanical stop structure **142** is the upper surface of the surgical stent **110** and/or surgical guide **112**. The mechanical stop structure **142** is substantially adjacent to or near the surgical guide **112**. The mechanical stop structure **142**, however, could be positioned at locations of the surgical stent **110** beyond the surgical guide **112**. Alternative preferred mechanical stop structure **142** includes a protrusion on the upper surface or a notch in the upper surface). The size and shape of the mechanical stop structure **142** is determined (calculated or designed) by a process that may be implemented as software or as a program and is based upon tooth bud volumes determined in pre-surgical volume scanning **82** as well as the length between the ablation probe tip mechanical stop structure **140** and its center of ablation **130a**. For example, if the middle of the tooth bud **130b** is 2.5 mm below the surface (determined in pre-surgical volume scanning **82**), and the available ablation probe tips **108** have a length (between their respective mechanical stop structure **140** and its center of ablation **130a**) of 2.4 mm and 2.6 mm, the process (that may be implemented by software or a program) would determine that the 2.6 mm ablation probe tip **108** is the appropriate ablation probe tip **108** (the 2.4 mm ablation probe tip **108** being too short), but that the surgical stent **110** and/or surgical guide **112** would have to be approximately 0.1 mm thick to make up the difference or the 2.6 mm ablation probe tip **108** would be able to be pushed in too far.

FIG. **12** is a flowchart showing the steps of a process (that may be implemented as one or more software program or subprograms if the shown steps are divided) that, in part, determines the pre-defined angle (ϕ) and the pre-defined depth (x) (see steps **200**, **210**, **212**, **214**, **216**, and **218**). Using this process, patient volume scans are used to accurately manufacture or fabricate custom surgical stents **110** with the correct ablation probe tip angle (ϕ) and depth (x) manufactured into them. More specifically, using this process with the volume scans will permit accurate placement of the distal surgical guides **112** onto the custom surgical stents **110** so that both angle (ϕ) of insertion and depth (x) of insertion of the ablation probe tip **108** are controlled to ±0.5 mm, placing the ablation probe tip's effective center of ablation **130a** in the middle of the tooth bud **130b**.

The following bulleted points are exemplary details and/or features that may be incorporated in preferred stents **110**.

- Preferred surgical stents **110** are preferably disposable (e.g. single-use).

- Manufacturing or fabricating of the custom surgical stents **110** may be based upon PVS full arch impressions of the

15

patient's erupted teeth using either conventional lab fabrication techniques or direct-digital manufacturing or fabricating techniques. If an operator has a CBCT unit in his office, it may be possible to directly scan the PVS impressions and email the volume scan of the impression to eliminate the need to physically send them to the lab. The impression materials may include materials other than PVS and preferably will be contrast-optimized through the addition of X-ray contrast agents (such as barium or iodine) to provide optimized volume scans of the dental impression for resolving the fine surface detail of the teeth and gingival tissue **122**. This unique material would be a radiographic contrast-optimized dental impression material for high resolution X-ray CT volume scanning.

Preferred surgical stents **110** are preferably made of any appropriate material including, but not limited to plastic, acrylic, or other nontoxic sturdy material suitable for use in a patient's mouth. One exemplary surgical stent **110** composition may be, for example, clear acrylic (polymethyl methacrylate). It should be noted that materials suitable for additive-type manufacturing (or other direct-digital manufacturing or fabricating techniques) that resulted in nontoxic sturdy stents would be preferable.

Preferred surgical stents **110** preferably have markings such as color codes or numbering clearly marking or identifying the tooth bud numbering sites.

Once the surgical stent **110** is seated onto the patient's teeth, it preferably will remain firmly in place throughout the surgical phase **90** of the TBA procedure **70**.

The operator may administer local anesthetic through the guides **112**.

Pre-Determined Settings **105**

The pre-determined settings **105** include, for example, pre-determined parameter settings **105a** and/or treatment time settings **105b** that are needed to control (provide instructions to) the generator **104** (alone or as part of an ablation probe unit **102**) to provide sufficient ablation means **104'** to ablate the tooth bud **120**, but not so much as to incur significant collateral soft tissue damage (e.g. to the gingival tissue **122**). For example, the pre-determined parameter settings **105a** might control the quantity and quality ablation means **104'** delivered to the tooth bud **120**. The actual pre-determined parameter settings **105a** will be highly dependent on the type of ablation means **104'** to be delivered. For example, MW and RF ablation means might have parameters relating to wavelength and/or frequency, hot tip ablation means might have parameters relating to temperature, chemical ablation means might have parameters relating to the strength of the chemical and how fast the chemical is flowing into the tooth bud, and mechanical ablation means might have parameters relating to speed.

The pre-determined settings **105** are determined (which includes computing, calculating, looking up, processing, or otherwise determining) by a process (that may be implemented as software or a program) based upon tooth bud volumes determined in pre-surgical volume scanning **82**. It should be noted that the pre-determined settings **105** may take into consideration factors other than tooth bud volume including, but not limited to image recognition programs to measure tooth bud location, age and size of the patient, and other relevant factors to successfully image the patient for the TBA procedure **70**. FIG. **12** is a flowchart showing the steps of a process (that may be implemented as one or more software program or subprograms if the shown steps are divided) that,

16

in part, determines the pre-determined parameter settings **105a** and/or treatment time settings **105b** (see steps **200**, **220**, **222**, and **224**).

The generator **104** (and/or the ablation probe unit **102**) may be programmed by the operator and/or technicians at the laboratory and/or factory. The programming may be automatic or manual. "Programming" includes having the pre-determined settings **105** pre-entered and/or entering (inputting) the pre-determined settings **105** manually or automatically into the generator **104** (and/or the ablation probe unit **102**) via operator input mechanisms. For example, the pre-determined settings **105** may be preprogrammed into an ablation probe unit **102**, transmitted to the operator in the form of a programming signal (e.g. over the internet to be downloaded and installed in the ablation probe unit **102** or the generator **104**), provided in the form of computer-readable media (e.g. a disc or a solid state USB drive), and/or provided as data (or a code) that may be manually entered into the ablation probe unit **102** (or the generator **104**). Ideally, whichever method of entering/programming the ablation probe unit **102** (or the generator **104**) is used, operator error is considered and eliminated as much as possible and appropriate checks are used. Preprogramming and some of the other means for programming the ablation probe unit **102** (or the generator **104**) with the pre-determined settings would help to eliminate operator input errors. Another example of means for eliminating errors is that even if the ablation probe unit **102** (or the generator **104**) is preprogrammed by the laboratory, the pre-determined settings might be displayed to the user for independent "verification" as the user could notice variations from normal pre-determined settings (e.g. the literature provided might provide a range and the operator would notice if the provided pre-determined settings **105** fell outside of the range). Yet another example is that the pre-determined settings might be provided as a code that, when input, would only function if it corresponded with a logical setting (e.g. if the person's age was also input into the ablation probe unit **102** and the code was not a logical setting based on the age, the ablation probe unit **102** would not function).

The pre-determined settings **105** for each TBA site may be included in the TBA surgical kit as a print out, on a disk or other computer readable storage media, or with instructions on how to obtain or download the information.

The pre-determined ablation means parameter settings **105a** can also be referred to as "parameter settings **105a**," "preferred parameter settings **105a**," "optimal parameter settings **105a**," "ideal parameter settings **105a**," "pre-determined parameter settings **105a**," "recommended parameter settings **105a**," or "prescribed parameter settings **105a**."

Tissue Trocar **146**

If the ablation probe tip **108** is not self-introducing, at least one sharp instrument (that is preferably disposable) such as a tissue trocar **146** (and sometimes a plurality of tissue trocars) may be used by the operator to introduce (initially create) the access opening through the thick attached gingival tissue **122** that overlays third molar tooth buds **120**. The tissue trocar tips are preferably sharp enough to be pushed and/or punched through the gingival tissue **122** into the base of the tooth bud. The diameter of the tissue trocar **146** rapidly increases up to 100% of the size of the ablation probe tip **108**. After the tissue trocar **146** has created the access opening, the tissue trocar **146** is removed and the ablation probe tip **108** is immediately placed into the access opening.

TBA Surgical Kit

The TBA surgical kit is a package that includes the majority of the necessary components and information for the surgical phase **90** of the TBA procedure **70**. The TBA kit will be

assembled (or the assembly will be completed) based on the patient's impressions and volume scans. Preferably the TBA surgical kit has attractive packaging.

An exemplary TBA surgical kit may consist of (a) a custom surgical stent **110** for each arch as required, (b) at least one ablation probe tip **108** labeled its respective surgical site, (c) at least one tissue trocar **146** (if necessary), and (d) pre-determined settings **105** for each TBA site along with patient and operator identification.

If feedback controls are a part of the ablation probe tip design, then the correct in situ tissue temperature settings are preferably computed and supplied with the ablation probe tips **108** as part of the surgical kit.

The generator **104** and/or the hand pieces **106** are standard equipment in a dental office and/or can be purchased separately.

The ablation probe tips **108** may be pre-purchased (or extras may be kept in a practitioner's office) in which case the TBA surgical kit would provide a part number or other identifying information so that the practitioner would know which ablation probe tip **108** should be used with each guide **112**.

It should be noted some of the components may not be part of the physical TBA surgical kit. For example the pre-determined settings **105** may be provided by electronically.

The TBA Procedure **70**

Using the TBA procedure **70** described herein, the effective center of ablation **130a** of the ablation probe tip **108** can be positioned at a pre-defined angle (ϕ) and pre-defined depth (x) so that the ablation probe tip's effective center of ablation **130a** is positioned substantially in the "middle" of the tooth bud **130b** within approximately 50%, 25%, or even less than 10% of the average diameter of the tooth bud **120**. This is extremely accurate as compared to previous procedures.

FIG. **4** shows the steps and/or phases in an exemplary preferred TBA procedure **70**: (1) routine screening and diagnosis **72**; (2) pre-surgical scanning **82** (including taking impressions **84** and using scanning technology **86**); (3) assembling a TBA surgical kit **88** (including pre-determined settings **105** and a stent **110**); (4) operator delivery of the surgical phase **90** of the TBA procedure **70** (shown in more detail in FIG. **11**); and (5) post-surgical steps **98**. Steps (2) and (3) are also referred to jointly as the pre-surgical phase **80** during which steps are taken to create (including calculating, manufacturing, fabricating, selecting, and/or assembling) components of the TBA system **100** and/or the TBA surgical kit to be provided to the operator. Step (4) is also referred to as the surgical phase **90** of the TBA procedure **70** during which the steps shown in FIG. **11** are taken to ablate tooth buds **120**.

(1) Screening Phase **72**

Routine screening using panoramic or intra-oral X-ray imaging techniques is necessary to identify the presence of forming tooth buds **120** starting at age 6 through age 12 because of the wide range of ages involved with the formation of third molar tooth buds **120**.

(2) Impressions and Scanning of Pre-Surgical Phase **80**

Once third molar tooth buds **120** have been identified to be present using standard screening methods (screening phase **72**), the next step is to pre-operatively measure the precise three-dimensional location and volume of each third molar tooth bud **120**. This may be practically accomplished using scanning technology **86** (e.g. computed tomography volume scanning such as dental cone beam computed tomography (CBCT)). Scanning technology **86** can be used to accurately generate the necessary 3-dimensional volume scans (com-

puted tomography volume scans) and measurements ± 0.2 mm using, for example, the distal side of erupted first molars as durable physical landmarks (although it is possible to use soft tissue over bone as landmarks). The scanning technology **86** produces tooth bud size and position data **86'** (also referred to as "volume scans" and/or "measurements") that is provided for the step of producing the TBA surgical kit **88**. The tooth bud size and position data **86'** may be provided as a scanning technology file that can be any data file generated by the scanning technology **86** with the data necessary to manufacture or fabricate a stent **110**. One exemplary type of scanning technology file is a 3-D CAD file.

An impression **84** of the patient's teeth and gum tissue (gingival tissue **122**) is made using standard impression materials such as polyvinyl siloxane (PVS)-type impression material (although other impression materials can be used). The impressions **84** are then processed and/or scanned using scanning technology (e.g. CBCT imaging by dentists and/or CT imaging in the laboratory), and the resulting volume scan of the impression is emailed (or otherwise transmitted or delivered) to a laboratory and/or factory where the volume scan is used for manufacturing or fabricating. It is still possible to physically mail the PVS dental impressions **84** to the designated laboratory and/or factory for manufacturing or fabricating.

Although the scanning technology is discussed primarily in terms of computed tomography volume scanning (e.g. cone beam computed tomography (CBCT) technology), alternative scanning technologies including, but not limited to ultrasound scanning technologies and future developed scanning technologies are included in the scope of the invention. Specialty software or programs may be used with the scanning technology **86** to accomplish the purpose described herein. It should be noted that alternative scanning technology **86** (including future developed scanning technology) may be used if it is able to accurately generate the necessary 3-dimensional volume scans and measurements ± 0.2 mm using the distal side of erupted first molars (or other landmarks) as durable physical landmarks. It should be noted that alternative scanning technology (including future developed scanning technology) may also be used as long as two- or three-dimensional scanning results in the positioning of the effective center of ablation **130a** within approximately 50%, 25%, or even less than 10% of the average diameter of the tooth bud **120**.

(3) Assembling a TBA Surgical Kit **88**

The pre-surgical phase **80** of the TBA procedure **70** includes assembling a TBA surgical kit **88**. This step of assembling a TBA surgical kit **88** preferably includes computing pre-determined settings **105** and manufacturing or fabricating the stent **110** based on tooth bud size and position data **86'** obtained from the scanning technology **86**. The process of computing pre-determined settings **105** may be controlled by a process (that may be implemented by software or a program). The process of manufacturing or fabricating the stent **110** may also be controlled by a process (that may be implemented by software or a program).

After the impressions **84** are processed and/or scanned and the tooth bud size and position data **86'** is obtained, the process of manufacturing or fabricating the stent **110** may be carried out using direct-digital manufacturing or fabricating techniques similar to the processes used for manufacturing or fabricating implant surgical stents directly from CBCT scans (e.g. the processes used for fabricating SurgiGuide™ and other implant surgical guides) and the process used for manufacturing or fabricating orthodontic aligners (e.g. orthodontic aligners made by Align Technology or ClearCorrect). The

direct-digital manufacturing or fabricating techniques, however, use the tooth bud size and position data **86'** to position and angle the surgical guides **112** on the distal aspects of the surgical stents **110** and use the erupted first molars as the primary landmark for positioning. Although manufacturing or fabricating will usually be done remotely in a laboratory and/or factory, it is possible that larger clinics will have the ability to manufacture or fabricate surgical stents **110** in their own in house laboratory and/or factory.

Direct-digital manufacturing or fabricating techniques can be defined as any manufacturing or fabricating process that creates physical parts directly from data (e.g. 3-D CAD files) using manufacturing or fabricating techniques including, but not limited to surgical stent manufacturing or fabricating technologies, rapid turn-around fabrication technologies, computer aided manufacturing (CAM), technologies using computer aided design (CAD), CNC milling, "additive" manufacturing, direct-digital laser stereolithography fabrication, "3-D printing," or any other manufacturing or fabricating means known or yet to be discovered that is capable of using the results generated by scanning to manufacture or fabricate the custom surgical stents. Because of the possibility for the integrated use of direct-digital volume scanning of impressions, low manufacturing costs, and rapid turn around times, use direct-digital manufacturing or fabricating techniques is one preferred manufacturing or fabricating technique, but more traditional manufacturing or fabricating techniques that require more labor intensive manual laboratory processing could also be used.

At least one process that may be implemented as software or as at least one program (e.g. custom software enhancements in the CBCT software) will preferably assist in the direct-digital manufacturing or fabricating of the surgical stents **110** and define (and/or compute or calculate) the pre-determined settings **105**. This process would include defining (and/or computing or calculating) positioning and entry angle data required for placement of the ablation probe tip's effective center of ablation **130a** into the middle of the targeted tooth bud **120**. Additionally, tooth bud volumes are preferably computed (possibly using the scanning technology) and then the tooth bud volumes are used to determine the pre-determined settings **105** necessary to effect therapeutic ablation. Tooth bud volumes will generally range from 4.0 mm to 12.0 mm in diameter at ages 6-12. The ablation means **104'** and treatment times are preferably considered in the calculations. Companies that make CBCT imaging equipment promote the development of procedure-specific software in order to gain end-user acceptance of their imaging systems in the market place. The process may use calculations and/or look-up charts (e.g. based on experimental data) for determining the necessary settings.

FIG. **12** is a flowchart showing the steps of a process (that may be implemented as one or more software programs or subprograms if the shown steps are divided) for manufacturing or fabricating custom surgical stents **110** and/or determining the pre-determined parameter settings **105a** and/or treatment time settings **105b**. As shown, the process begins with receiving pre-operative measurements of the precise three-dimensional location and volume of each third molar tooth bud and information regarding the ablation probe unit including its ablation means capabilities **200**. To make the stents **110**, the process would preferably include the following steps: determining an entry point for an ablation probe tip **210**; computing the angle and depth of the path between the entry point and the middle of a tooth bud **212**; taking into consideration the depth of the path, creating or selecting an ablation probe tip having the proper distance between its

mechanical stop and its center of ablation so that the ablation probe tip will be inserted so that its center of ablation will be in the middle of the tooth bud **214**; taking into consideration the angle and depth of the path and the thickness of the surgical stent, computing the surgical guide pathway through which the ablation probe tip will be inserted so that its center of ablation will be in the middle of the tooth bud **216**; and providing the surgical guide pathway as output for the creation of a surgical stent with surgical guides **218**. To calculate the pre-determined parameter settings **105a** and/or treatment time settings **105b**, the process would preferably include the following steps: taking into consideration the information regarding the ablation probe unit including its ablation means capabilities, determining the proper power settings **220**; taking into consideration the information regarding the ablation probe unit including its ablation means capabilities, determining the proper time settings **222**; and providing the proper power and time settings as output for use in programming the ablation probe unit or generator **224**.

As described above, in addition to the surgical stent(s) **110** and the pre-determined settings **105**, the TBA surgical kit may include at least one ablation probe tip **108** labeled for its respective surgical site, at least one tissue trocar **146** (if necessary), and patient and operator identification.

The TBA surgical kit is provided to the operator.

(4) Surgical Phase **90**

FIGS. **6-10** show graphically, and FIG. **11** shows as a flow chart, the surgical phase **90** of the TBA procedure. The surgical phase **90** may be performed by a dental operator (dental practitioner) in his office (e.g. a pediatric and/or general dental offices) under normal office conditions. At this point, the generator **104** has been programmed with the pre-determined settings **105** and normal surgical procedures have been followed. The generator **104** is preferably tuned so that the ablation means **104'** is set to ablate the small, substantially spherical ablation volumes of third molar tooth buds **120** in order to minimize (or possibly eliminate) collateral osseous and soft tissue damage, especially damage to adjacent second molars that are likely not yet erupted. Further, the surgical phase **90** uses single-use and disposable delivery systems that use components designed for intra-oral use.

Summarily, as shown in FIG. **11**, the first step is physically seating a surgical stent **160** in a patient's mouth. Next, the operator makes an access path at the at least one tooth bud surgical site **162**. The operator also places the ablation probe tip so that the center of ablation is in the middle of a tooth bud at the at least one tooth bud surgical site (using the custom surgical stent to guide the placement) **164**. It should be noted that if the ablation probe tip is "self-introducing," the step of making an access path and the step of placing the ablation probe tip may occur simultaneously. Then, the at least one tooth bud is at least partially ablated **166** and the ablation probe tip is removed from the tooth bud **168**. These and other exemplary steps are detailed in the following paragraphs.

The operator preferably starts the surgical phase **90** by placing the surgical stent **110** into place onto the patient's teeth prior to administering local anesthetic to the surgical site. The local anesthetic will then be administered through the surgical stent **110** and guides **112** that are in close approximation with the gingival tissue **122**, thus reducing the amount of anesthetic necessary because of the precise placement of anesthetic agent. Achieving local anesthesia in this procedure will be easier than anesthetizing lower permanent molar teeth for routine fillings since only soft tissues, which will be 8.0 mm to 15.0 mm deep, are involved.

The step of physically seating a surgical stent **110** may also include physically seating the surgical stent in a patient's

mouth, physically seating the surgical stent on a patient's erupted teeth, physically seating the surgical stent on at least one tooth in a patient's mouth, physically seating the surgical stent on a patient's soft tissue, physically seating the surgical stent on a patient's bone, or a combination of the above steps (e.g. physically seating the surgical stent on a patient's teeth, soft tissue, and bone).

Once the custom surgical stent **110** is in place and the patient is fully anesthetized, the operator then mechanically gains access to the tooth bud **120** through the stent surgical guides **112** by creating (introducing) a small surgical access path opening through the gingival tissue **122** approximately 0.1 mm to 2.0 mm (and more particularly 0.5 mm to 1.0 mm) in diameter using tissue trocars. If the ablation probe tips **108** are designed to be strong enough and sharp enough to act as "self-introducing" probe tips, they can be used to introduce the surgical access path. On the other hand, if the ablation probe itself is not self-introducing, the surgical access path may be introduced using a separate tissue trocar **146**.

It should be noted that the surgical access path is preferably an incision, a puncture, or a hole through the gingival tissue **122**. If a self-introducing probe tip is used, the surgical access path has substantially the same diameter as the ablation probe tip **108**. If the probe tip is not self-introducing, the surgical access path may be a sutureless puncture (0.1 mm to 2.0 mm in diameter) or, more particularly, a sutureless puncture (0.5 mm to 1.0 mm in diameter). Alternatively, a trocar "punch" may be made through tough gingival tissue **122**. Regardless of the procedure used to introduce the surgical access path, using a surgical access path to gain access or allow placement of the ablation probe tips **108** to the tooth bud **120** does not kill, damage, or otherwise cause necrosis to the surrounding soft tissues (e.g. gingival tissues **122**). This can be compared to other processes such as coring, boring, cutting, electro-surge ablating, or other invasive procedures that kill, damage, and/or otherwise cause necrosis to the soft tissue to which the invasive procedure has been applied. Although the preferred procedures for introducing the surgical access path might kill individual cells, the soft tissue (the gingival tissue **122**) does not become necrosed because the tissue is a collection of cells that can heal itself.

As shown in FIGS. **6** and **7**, the next step in the surgical phase **90** is to insert the designated ablation probe tip **108** through the surgical stent **110** and into the tooth bud space until it is mechanically "stopped" in order to position the probe to the prescribed depth (which would be the pre-defined depth). The surgical stent **110** and its surgical guides **112** are used to control the angle (Φ) and depth (x) of the ablation probe tip **108** so that the effective center of ablation **130a** of the ablation probe tip is in the middle of the tooth bud **130b**. It should be noted that the effective center of ablation **130a** for any given ablation technology does not necessarily correspond with the tip of the ablation probe. For instance, microwave ablation probes have windows or slots that may be 0.5 mm to 2.0 mm from the tip depending on the frequency of the wavelength used. Cryoablation probes have their center of ablation roughly in the middle of the probe, depending on the design and refrigerant used. A mechanical stop structure **140** on the ablation probe tip **108** preferably seats firmly onto the mechanical stop structure **142** of the surgical stent guide **112** to prevent over extension of the ablation probe tip **108**.

FIG. **8** shows embedded temperature sensors **144** (or other types of feedback control mechanisms) that may be used during the ablation process. An independent feedback process using the temperature sensors **144** is preferable for this clinical procedure. Use of temperature sensors **144** along with monitoring probe impedance characteristics and percentage

of reflected energy in RF/MW circuits will provide "go/no go" output for the clinician. Control algorithms are preferably used to accelerate initial ablation means **104'** input followed by lower-level temperature maintenance for a defined period of time with independent confirmation that results in a fast process while simultaneously assuring complete tooth bud ablation.

FIG. **9** shows the actual ablation process. Activation of the ablation probe unit **102** to perform the ablation process is executed according to the pre-determined settings **105**. Activation of the ablation probe unit **102** causes the generator **104** to provide the ablation means **104'** that passes through the hand piece **106** and the ablation probe tip **108** and into the tooth bud **120**. This step of at least partially ablating the tooth bud is preferably accomplished without ablating any surrounding gingival tissue (although a minimal amount of surrounding gingival tissue may be ablated as an accidental byproduct of the step). This can also be thought of as the activation of the ablation probe unit **102** creating a zone of ablation that resides predominantly or completely within the tooth bud **120**. The feedback control mechanisms **144** assure successful delivery of adequate ablation means **104'** to ablate the tooth bud **120** while minimizing damage to adjacent osseous and soft tissues by, for example, eliminating overheating. Given the small tissue volumes involved for pediatric patients, activation using an RF ablation means **104'** would have an ablation time that is preferably less than three (3) minutes and activation using an MW ablation means **104'** would have an ablation time that is preferably less than thirty (30) seconds.

FIG. **10** shows the ablation probe tip **108** being removed from the now ablated tooth bud **120'**. As shown in this figure, any access path created by the procedure rapidly closes.

(4) Post-Surgical Phase **98**:

After the surgical phase **90**, the patient may have follow-up including, but not limited to post-surgical instructions and, if necessary follow-up care and screening.

Post-surgical instructions that may be given to parents includes the following: kids can go out and play immediately unless they were sedated, no post-surgical pain medication is necessary, bleeding (if any) will be gone in minutes, and post-surgical X-ray screening may be necessary at patient's next routine 6-month hygiene cleaning appointment to verify full ablation.

Simulated TBA Procedure **70**

The following paragraphs, along with FIGS. **13-29**, detail an exemplary simulated TBA procedure **70** including routine screening and diagnosis **72**, the pre-surgical phase **80**, and the surgical phase **90**. In several of these figures, a patient's mouth **124** (with gums **122** and teeth **126**) is shown that looks like a stone model, but it should be understood that unless otherwise specified the shown mouth **124** would be a live patient's mouth.

As shown in FIG. **4**, the TBA procedure begins with routine screening and diagnosis **72**. FIG. **13** is a panoramic X-ray showing a patient whose third molar tooth buds **120** in the #17 & #32 positions are treatable by a TBA procedure **70**. FIG. **14** is a pre-operative cone beam computed tomography ("CBCT") scan (although other types of volume scanning could be used) of a patient. In a real procedure, the volume scan would be taken of the specific patient on which the TBA procedure **70** is being performed. This CBCT "reconstructed" panoramic scan has a 1.0 mm scale along its bottom edge. FIG. **15** is a series of CBCT volume scan cross-sections showing successive 1.0 mm slices through both #17 and #32 in 1.0 mm increments. Each X-ray corresponds to 1.0 mm

locations along the scale of FIG. 14. The left-side scale is 1.0 mm vertically. The maximum tooth bud diameters are measured to be 8.0-9.0 mm.

FIG. 16 shows a pre-operative upper-arch impression **84** being taken of the simulated patient's mouth **124** (shown as a stone model for clarity, but an impression **84** would be taken of the patient himself) using an impression tray **128**. It is assumed that all four tooth buds of the wisdom teeth are present in the simulated patient. FIG. 17 is a cross-sectional view of the upper-arch impression **84** being taken of a simulated patient. FIG. 18 shows the completed upper-arch impression **84**. A similar process would be performed to manufacture or fabricate a pre-operative lower-arch impression **84**. At this time the practitioner may send impressions **84** and volume scan data to a laboratory and/or factory for processing.

The laboratory and/or factory uses the impressions **84** and volume scan data (scanning technology file) to create (including calculating, manufacturing, fabricating, selecting, and/or assembling) components of the TBA system **100** (including the surgical stents **110** and the pre-determined settings **105**). The surgical stents **110** and the pre-determined settings **105** and other components are then assembled into the TBA surgical kit to be provided to the operator.

FIG. 19 shows the completed upper-arch impression **84**, along with a stone model **85** that will serve as a "positive" for manufacturing or fabricating a surgical stent **110** for that patient's upper-arch. Alternatively, when using stereolithography manufacturing to manufacture or fabricate surgical stents **110**, the impressions **84** can be computed tomography ("CT") scanned to digitize as an alternative to making physical intermediates. The CT volume scan file (scanning technology file) can then be emailed (or otherwise directly transmitted) for direct manufacturing or fabricating. Alternatively, the practitioner may handle the processing "in house."

FIG. 20 is a CBCT scan with notations showing the measurement of the perpendicular angle of entry into the tooth bud **120**. The measurement is based on the distal aspect of the molar and the occlusal bite plane of the teeth. FIG. 21 is a series of X-rays with notations showing the measurement of the lateral angle of entry. The measurement is determined relative to the vertical axis in order to avoid the jaw's boney interferences during surgical placement of the ablation probe unit **102**. FIG. 22 is a CBCT scan with highlights showing the computed volume of each tooth bud **120**. CBCT volume data is used to determine and/or calculate the pre-determined settings **105**.

FIG. 23 shows the resulting surgical stent **110** that will be placed in a patient's mouth **124**. The shown stent has two surgical guides **112** based upon the location of the patient's two tooth buds to be ablated.

The surgical stent(s) **110** and the pre-determined setting(s) **105** are provided to the operator along with the rest of the TBA surgical kit.

Prior to the surgical phase **90** of the TBA procedure **70**, the ablation probe unit **102** and/or the generator **104** should be set up so that at least one pre-determined setting **105** is correctly entered for at least one tooth bud **120** with safety interlocks carefully considered. (The pre-determined settings **105** may all be entered prior to the surgical phase **90** or they may be entered one at a time.) The surgical phase **90** of the TBA procedure **70** may then be performed.

FIG. 24 shows topical anesthetic **87** being applied to the base of the surgical guide **112** (FIG. 24) prior to the surgical stents **110** being seated in a patient's mouth **124**.

FIG. 25 shows the surgical stent **110** being seated on the upper arch of the simulated patient's mouth **124** (shown as a

stone model for clarity). This process would be repeated on the lower arch of the simulated patient.

FIG. 26 shows a local anesthetic being injected **89** into each site through a surgical guide **112** of the stent **110**.

FIG. 27 shows a tissue trocar **146** being used to create an access path through the gingival tissue **122** to the base of each tooth bud **120**. The tissue trocar **146** is only necessary if self-introducing ablation probe tips **108** are not used.

FIG. 28 shows an ablation probe tip **108** with mechanical stop structure **140'** (shown as a shoulder) being inserted through the surgical guide **112**. This would be similar to the position of the ablation probe tip **108** in FIG. 6.

FIG. 29 shows the ablation probe tip **108** positioned through the surgical guide **112** and into the tooth bud **120** through the surgical guide **112** so that the ablation probe tip's effective center of ablation **130a** is in the middle of each tooth bud **120**. This would be similar to the position of the ablation probe tip **108** in FIG. 7.

The ablation means **104'** is delivered in this position (FIG. 9). The ablation means **104'** is delivered based on the pre-determined settings **105** (e.g. times, intensities, and other prescribed settings unique to each tooth bud).

The ablation probe tip **108** would then be removed and the process repeated at the site of each tooth bud **120**. Once the entire surgical phase **90** is complete, the surgical stents **110** are removed.

Finally, the dental practitioner or an assistant provides post-surgical instructions to the patient or a caregiver of the patient.

Alternative Scanning and Fabrication of Custom TBA Surgical Kits

An alternative to the pre-surgical phase **80** of the TBA procedure **70** described above includes simultaneous three-dimensional scanning of both hard tissues (bone and teeth) and soft tissues (tooth bud **120** and gingival tissue **122**). From the information obtained using this unique simultaneous three-dimensional scanning, a custom surgical stent **110** may be manufactured or fabricated. As discussed, the custom surgical stent **110** is used in the surgical phase **90** to help with the placement of the center of ablation **130a** into a tooth bud **120** that results in tooth agenesis.

The simultaneous three-dimensional scanning uses a single scan to obtain both soft tissue and hard tissue information. Soft tissue information generally does not show on a scan, although progress in volume scanning is improving and this may be possible in the near future. Known and future technologies able to provide a scan image of soft tissue are included in the scope of this invention. A typical X-ray scan will only show the hard tissue. So to obtain both soft and hard tissue information using simultaneous three-dimensional scanning, a dental impression **84** is used that can be viewed on an X-ray. The dental impression **84** is made of materials that are preferably "contrast optimized" for high resolution X-ray volume scanning. The ideal level of contrast agent in the range of 25% to 75% radiopacity (such as barium or iodine based compounds) is mixed into the dental impression materials so that the highest level of surface detail can be picked upon when volume scanning the dental impression **84**. The dental impression **84** is placed in the patient's mouth **124** during the X-ray volume scan. The resulting X-ray volume scan image would show the tooth distinguished (is visible) and the dental impression **84** distinguished (is visible) and the void therebetween would be the soft tissue and would therefore be "visible." The resulting X-ray volume scan with both hard and soft tissue information may then be used to formulate the custom stent **110** used in the surgical phase **90** described herein. In other words, an X-ray volume scan image

is generated in which hard tissue (e.g. a tooth) is visible hard tissue and the dental impression **84** is a visible dental impression and soft tissue (e.g. gingival tissue **122**) is “visible” as the space between the visible hard tissue and the visible dental impression.

One separate preferred pre-surgical phase **80** of the TBA procedure **70** preferably includes using X-ray volume scans of dental impressions **84** to manufacture or fabricate surgical stents **110**. The X-ray volume scan of the dental impression **84** is “superimposed” over the patient X-ray volume scan (e.g. CBCT scanning) using the dental hard tissues (the teeth) to “snap” the two volume scans together into an accurate overlay so that soft tissues of the mouth (which cannot be X-ray volume scanned directly) are accurately defined for the surgical stent manufacturing or fabricating (which must take into account the soft tissue and teeth) and probe positioning (which must take into account the tooth bud positioning from the patient’s CBCT scan).

One separate preferred pre-surgical phase **80** of the TBA procedure **70** preferably includes using dental impression materials that are “contrast optimized” for high resolution X-ray volume scanning that is then used to manufacture or fabricate surgical stents **110**. The ideal level of contrast agent (such as barium or iodine based compounds) is mixed into the dental impression materials so that the highest level of surface detail can be picked upon when CT volume scanning the dental impression **84**.

Alternative Procedures and Systems

Separate preferred surgical procedures preferably include the ablation of “non-tooth” bud lesions or tumors of the maxilla or mandible. In such a situation, a custom stent would be manufactured or fabricated with guides to guide an ablation probe tip **108** to such a lesion or tumor located at least one lesion or tumor surgical site. The process could then be used to ablate such lesion or tumor.

Separate TBA surgical procedures preferably include the use of ultrasound scanning with combined ultra-high energy ultrasound ablation but without the use of a surgical stent for transgingival tooth bud ablation that results in tooth agenesis. This can be described as direct ultrasound scanning with ultra-high energy ultrasound built into the same scanning head.

Comparison to the Silvestri Study

As set forth in the Background section of this document, the article entitled “Selectively Preventing Development Of Third Molars In Rats Using Electrosurgical Energy” by Silvestri et al. describes a pilot study that tests the hypothesis that third molars can be selectively prevented from developing. The results of the Silvestri study were mixed at best, with only ten rats out of thirty-three showing the desired result of no intraoral or radiographic evidence of third molar development. One reason that the Silvestri process was not successful may have had to do with the fact that the Silvestri process was inexact. For example, the Silvestri process relies on molds taken from molds of the mouths of euthanized rat pups rather than using molds fabricated for the rat pup on which the procedure was to be performed. The present invention uses the patient’s mouth on which the procedure is to be performed. Another way in which the Silvestri process was inexact was that the Silvestri process did not locate the forming tooth bud **120**. More specifically, the Silvestri process did not locate or determine the location of the forming tooth bud **120** pre-operatively relative to the landmarks that he used. Silvestri even states “. . . when electrosurgical energy is applied near the invisible tooth anlage in the tiny mouth of newborn rats, the effects of the electrosurgical energy cannot be nearly as local or precise. The embryonic tooth-forming tissues of

the third molar [lay] fractions of a millimeter below the oral mucosa and cannot be seen. As a result, it was not possible to predictably protect and isolate the vulnerable developing bone from the energy and heat of the electrosurgical energy.

The result was a relatively large, unpredictable area of tissue damage during treatment and a wide range of bony developmental effects seen after the rats were euthanized.” The TBA procedure **70** described herein can be distinguished from the Silvestri procedure in several ways including for example, that (1) the TBA procedure **70** described herein is a minimally invasive procedure consisting of introducing a surgical access path at each tooth bud surgical site as opposed to the boring, killing, and damaging procedure described by Silvestri (2) the TBA procedure **70** described herein is performed in such a manner that it can be described as exact (e.g. using the patient’s mouth as the mold for manufacturing or fabricating the surgical stent **110**, taking exact measurements of the patient’s mouth (including the position of the tooth bud **120**), and using calculated parameter and time settings **105b**) as opposed to the Silvestri procedure that can be described as inexact, and (3) the TBA procedure **70** described herein can predictably ablate tooth buds **120** as opposed to the Silvestri procedure that was essentially unpredictable and could never, under any circumstances, be considered for treating human patients.

Flow Charts

FIGS. **4**, **11**, and **12** are flow charts illustrating processes, methods, and/or systems. It will be understood that at least some of the blocks of these flow charts, components of all or some of the blocks of these flow charts, and/or combinations of blocks in these flow charts, may be implemented by software (e.g. coding, software, computer program instructions, software programs, subprograms, or other series of computer-executable or processor-executable instructions), by hardware (e.g. processors, memory), by firmware, and/or a combination of these forms. As an example, in the case of software, computer program instructions (computer-readable program code) may be loaded onto a computer (or on a special purpose machine such as a volume scanner or scanning technology) to produce a machine, such that the instructions that execute on the computer create structures for implementing the functions specified in the flow chart block or blocks. These computer program instructions may also be stored in a memory that can direct a computer to function in a particular manner, such that the instructions stored in the memory produce an article of manufacture including instruction structures that implement the function specified in the flow chart block or blocks. The computer program instructions may also be loaded onto a computer (or on a special purpose machine such as a volume scanner or scanning technology) to cause a series of operational steps to be performed on or by the computer to produce a computer implemented process such that the instructions that execute on the computer provide steps for implementing the functions specified in the flow chart block or blocks. The term “loaded onto a computer” also includes being loaded into the memory of the computer or a memory associated with or accessible by the computer (or on a special purpose machine such as a volume scanner or scanning technology). The term “memory” is defined to include any type of computer (or other technology)-readable media including, but not limited to attached storage media (e.g. hard disk drives, network disk drives, servers), internal storage media (e.g. RAM, ROM), removable storage media (e.g. CDs, DVDs, flash drives, memory cards, floppy disks), and/or other storage media known or yet to be discovered. The term “computer” is meant to include any type of processor, programmable logic device, or other type of programmable

apparatus known or yet to be discovered. Accordingly, blocks of the flow charts support combinations of steps, structures, and/or modules for performing the specified functions. It will also be understood that each block of the flow charts, and combinations of blocks in the flow charts, may be divided and/or joined with other blocks of the flow charts without affecting the scope of the invention. This may result, for example, in computer-readable program code being stored in whole on a single memory, or various components of computer-readable program code being stored on more than one memory.

Additional Information

It is to be understood that the inventions, examples, and embodiments described herein are not limited to particularly exemplified materials, methods, and/or structures. Further, all publications, patents, and patent applications cited herein, whether supra or infra, are hereby incorporated by reference in their entirety.

Please note that the terms and phrases may have additional definitions and/or examples throughout the specification. Where otherwise not specifically defined, words, phrases, and acronyms are given their ordinary meaning in the art. The following paragraphs provide some of the definitions for terms and phrases used herein.

The terms “fabricating” and/or “manufacturing” include any suitable means of making a component (e.g. stent 110). Although the terms are used together throughout most of the specification (e.g. “manufacturing or fabricating”), the absence of one term or another is irrelevant because they are used herein synonymously.

The terms “proper,” “correct,” “optimal,” and “ideal,” are relative and may become more accurate as technology is developed. For example, when used in terms of the pre-defined angle (ϕ) and pre-defined depth (x) that are calculated and/or prescribed (e.g. the “proper angle and depth,” the “correct angle and depth,” the “optimal angle and depth,” or the “ideal angle and depth”), these phrases are meant to include the best possible angle and depth that is calculated using the best available information and technology.

The terms “provide” and “providing” (and variations thereof) are meant to include standard means of provision including “transmit” and “transmitting,” but can also be used for non-traditional provisions as long as the data is “received” (which can also mean obtained). The terms “transmit” and “transmitting” (and variations thereof) are meant to include standard means of transmission, but can also be used for non-traditional transmissions as long as the data is “sent.” The terms “receive” and “receiving” (and variations thereof) are meant to include standard means of reception, but can also be used for non-traditional methods of obtaining as long as the data is “obtained.”

It should be noted that the terms “may” and “might” are used to indicate alternatives and optional features and only should be construed as a limitation if specifically included in the claims. It should be noted that the various components, features, steps, phases, or embodiments thereof are all “preferred” whether or not it is specifically indicated. Claims not including a specific limitation should not be construed to include that limitation.

It should be noted that, unless otherwise specified, the term “or” is used in its nonexclusive form (e.g. “A or B” includes A, B, A and B, or any combination thereof, but it would not have to include all of these possibilities). It should be noted that, unless otherwise specified, “and/or” is used similarly (e.g. “A and/or B” includes A, B, A and B, or any combination thereof,

but it would not have to include all of these possibilities). It should be noted that, unless otherwise specified, the term “includes” means “comprises” (e.g. a device that includes or comprises A and B contains A and B but optionally may contain C or additional components other than A and B). It should be noted that, unless otherwise specified, the singular forms “a,” “an,” and “the” refer to one or more than one, unless the context clearly dictates otherwise.

The terms and expressions that have been employed in the foregoing specification are used as terms of description and not of limitation, and are not intended to exclude equivalents of the features shown and described. This application is intended to cover any adaptations or variations of the present invention. It will be appreciated by those of ordinary skill in the art that any arrangement that is calculated to achieve the same purpose may be substituted for the specific embodiment shown. It is also to be understood that the following claims are intended to cover all of the generic and specific features of the invention herein described and all statements of the scope of the invention which, as a matter of language, might be said to fall therebetween.

What is claimed is:

1. A human third molar tooth bud ablation procedure that results in tooth agenesis, the tooth bud ablation procedure comprising:

(a) physically seating a custom surgical stent fabricated for a specific patient having at least one surgical guide so said at least one surgical guide corresponds to at least one tooth bud surgical site, said at least one surgical stent fabricated using a process comprising:

(i) obtaining a volume scan image in which hard tissue is visible;

(ii) obtaining a volume scan image in which a dental impression is visible;

(iii) superimposing the volume scan image of the hard tissue with the volume scan image of the dental impression to create an overlay so that soft tissue is “visible” as the space between the visible hard tissue and the visible dental impression; and

(iv) manufacturing or fabricating said custom surgical stent with at least one ablation probe tip guide for guiding at least one ablation probe tip to a pre-defined angle and depth of ablation based on information obtained from said volume scan images;

(b) using said at least one surgical guide, making a surgical access path at said at least one tooth bud surgical site;

(c) using said at least one surgical guide, guiding placement of an ablation probe tip having a center of ablation so that said center of ablation is in a measured middle of a tooth bud at said at least one tooth bud surgical site; and

(d) at least partially ablating at least one tooth bud, said at least one tooth bud being the tooth bud of a human third molar.

2. The tooth bud ablation procedure of claim 1, said step of guiding placement of an ablation probe tip further comprising the step of positioning said ablation probe tip through said at least one surgical guide at a pre-defined angle and depth using a mechanical relationship of said ablation probe tip and said at least one surgical guide to form a “stop” therebetween.

3. The tooth bud ablation procedure of claim 1, said step of guiding placement of an ablation probe tip further comprising the step of gaining access to said at least one tooth bud without causing necrosis to surrounding gingival tissue.

4. The tooth bud ablation procedure of claim 1, said step of at least partially ablating at least one tooth bud further comprising the step of creating a zone of ablation that resides only within said at least one tooth bud.

29

5. The tooth bud ablation procedure of claim 1, said step of at least partially ablating at least one tooth bud further comprising the step of at least partially ablating at least one tooth bud without ablating surrounding gingival tissue.

6. The tooth bud ablation procedure of claim 1 further comprising the step of using a self-introducing ablation probe tip for said steps of making a surgical access path and guiding placement.

7. The tooth bud ablation procedure of claim 1, said step of guiding placement of an ablation probe tip further comprising guiding placement of said ablation probe tip so that said center of ablation is positioned within approximately 50% of the average diameter of the tooth bud.

8. The tooth bud ablation procedure of claim 1, said step of guiding placement of an ablation probe tip further comprising guiding placement of said ablation probe tip so that said center of ablation is positioned within approximately 25% of the average diameter of the tooth bud.

9. The tooth bud ablation procedure of claim 1, said step of guiding placement of an ablation probe tip further comprising guiding placement of said ablation probe tip so that said center of ablation is positioned within approximately 10% of the average diameter of the tooth bud.

10. The tooth bud ablation procedure of claim 1 further comprising the step of entering or programming at least one pre-determined setting into an ablation probe unit, said step of entering or programming selected from the group consisting of:

- (a) entering at least one ablation means parameter setting into said ablation probe unit;
- (b) entering at least one treatment time setting into said ablation probe unit;
- (c) programming at least one ablation means parameter setting into said ablation probe unit; and
- (d) programming at least one treatment time setting into said ablation probe unit.

11. The tooth bud ablation procedure of claim 1 further comprising the step of entering or programming at least one pre-determined setting into a generator, said step of entering or programming selected from the group consisting of:

- (a) entering at least one ablation means parameter setting into said generator;
- (b) entering at least one treatment time setting into said generator;
- (c) programming at least one ablation means parameter setting into said generator; and
- (d) programming at least one treatment time setting into said generator.

12. The tooth bud ablation procedure of claim 1, said step of physically seating a custom surgical stent having at least one surgical guide so said at least one surgical guide corresponds to at least one tooth bud surgical site further comprising the step of physically seating a custom surgical stent in a patient's mouth.

13. The tooth bud ablation procedure of claim 1, said step of physically seating a custom surgical stent having at least one surgical guide so said at least one surgical guide corresponds to at least one tooth bud surgical site further comprising a physically seating step selected from the group consisting of:

- (a) physically seating said custom surgical stent in a patient's mouth;
- (b) physically seating said custom surgical stent on a patient's erupted teeth;
- (c) physically seating said custom surgical stent on at least one tooth in a patient's mouth;

30

(d) physically seating said custom surgical stent on a patient's soft tissue;

(e) physically seating said custom surgical stent on a patient's bone; and

(f) physically seating said custom surgical stent according to any combination of steps (a)-(e).

14. The tooth bud ablation procedure of claim 1 further comprising the step of administering local anesthetic using said at least one surgical guide after said step of physically seating said custom surgical stent.

15. The tooth bud ablation procedure of claim 1 wherein said step of making a surgical access path further includes the step of making a 0.1 mm to 2.0 mm surgical access path.

16. The tooth bud ablation procedure of claim 1 wherein said step of at least partially ablating at least one tooth bud further comprises the step of at least partially ablating at least one tooth bud using ablation means.

17. The tooth bud ablation procedure of claim 1 wherein said step of at least partially ablating at least one tooth bud further comprises the step of at least partially ablating at least one tooth bud using an ablation means selected from the group consisting of:

- (a) microwave;
- (b) radio frequency;
- (c) irreversible electroporation;
- (d) cryoablation;
- (e) ultra-high intensity ultrasound;
- (f) laser;
- (g) chemical;
- (h) hot tip;
- (i) mechanical; and
- (j) a combination of at least two ablation energy means set forth in (a)-(i).

18. The tooth bud ablation procedure of claim 1 wherein said step of at least partially ablating at least one tooth bud further comprises the step of at least partially ablating at least one tooth bud using microwave ablation.

19. The tooth bud ablation procedure of claim 1 wherein said step of at least partially ablating at least one tooth bud further comprises the step of at least partially ablating at least one tooth bud using radio frequency ablation.

20. The tooth bud ablation procedure of claim 1 wherein said step of at least partially ablating at least one tooth bud further comprises the step of at least partially ablating at least one tooth bud using irreversible electroporation ablation.

21. The tooth bud ablation procedure of claim 1 wherein said step of at least partially ablating at least one tooth bud further comprises the step of at least partially ablating at least one tooth bud using cryoablation.

22. The tooth bud ablation procedure of claim 1 wherein said step of at least partially ablating at least one tooth bud further comprises the step of at least partially ablating at least one tooth bud using ultra-high intensity ultrasound ablation.

23. The tooth bud ablation procedure of claim 1 wherein said step of at least partially ablating at least one tooth bud further comprises the step of at least partially ablating at least one tooth bud using laser ablation.

24. The tooth bud ablation procedure of claim 1 wherein said step of at least partially ablating at least one tooth bud further comprises the step of at least partially ablating at least one tooth bud using chemical ablation.

25. The tooth bud ablation procedure of claim 1 wherein said step of at least partially ablating at least one tooth bud further comprises the step of at least partially ablating at least one tooth bud using mechanical ablation.

26. The tooth bud ablation procedure of claim 1 wherein said step of at least partially ablating at least one tooth bud

31

further comprises the step of at least partially ablating at least one tooth bud using hot tip ablation.

27. The tooth bud ablation procedure of claim 1 wherein said step of at least partially ablating at least one tooth bud further is performed using a hand-held integrated ablation probe unit with feedback controls.

28. The tooth bud ablation procedure of claim 1 further comprising the step of performing a pre-surgical phase.

29. The tooth bud ablation procedure of claim 1 further comprising the step of performing routine screening and diagnosis.

30. The tooth bud ablation procedure of claim 1 further comprising the step of making said dental impression.

31. The tooth bud ablation procedure of claim 1, said step of obtaining a volume scan image in which hard tissue is visible and said step of obtaining a volume scan image in which a dental impression is visible being pre-surgical volume scanning.

32. The tooth bud ablation procedure of claim 1, said step of obtaining a volume scan image in which hard tissue is visible and said step of obtaining a volume scan image in which a dental impression is visible being pre-surgical computed tomography volume scanning.

33. The tooth bud ablation procedure of claim 1 further comprising the step of computing tooth bud volumes.

34. The tooth bud ablation procedure of claim 1, said step of obtaining a volume scan image in which hard tissue is visible and said step of obtaining a volume scan image in which a dental impression is visible being pre-surgical volume scanning, said procedure further comprising the step of computing tooth bud volumes using results of said pre-surgical volume scanning.

35. The tooth bud ablation procedure of claim 1 further comprising the step of computing at least one pre-determined setting, said at least one pre-determined setting selected from the group of a pre-determined parameter setting and a treatment time setting.

36. The tooth bud ablation procedure of claim 1, said step of obtaining a volume scan image in which hard tissue is visible and said step of obtaining a volume scan image in which a dental impression is visible being pre-surgical volume scanning, said procedure further comprising the step of computing at least one pre-determined setting using results of said pre-surgical volume scanning.

37. The tooth bud ablation procedure of claim 1 further comprising the step of using a tooth bud ablation surgical kit including said custom surgical stent, said ablation probe tip, and an ablation probe unit programmable with at least one pre-determined setting.

38. The tooth bud ablation procedure of claim 1, said step of obtaining a volume scan image in which hard tissue is visible and said step of obtaining a volume scan image in which a dental impression is visible being pre-surgical volume scanning, said procedure further comprising the step of using at least one pre-determined setting with an ablation probe, said at least one pre-determined setting based upon tooth bud volumes determined using said pre-surgical volume scanning.

39. The tooth bud ablation procedure of claim 1, said step of guiding placement of an ablation probe tip further comprising guiding placement of said ablation probe tip so that said center of ablation is positioned within less than 50% of the average diameter of the tooth bud.

40. The tooth bud ablation procedure of claim 1, said step of guiding placement of an ablation probe tip further comprising guiding placement of said ablation probe tip so that

32

said center of ablation is positioned within less than 25% of the average diameter of the tooth bud.

41. The tooth bud ablation procedure of claim 1, said step of guiding placement of an ablation probe tip further comprising guiding placement of said ablation probe tip so that said center of ablation is positioned within less than 10% of the average diameter of the tooth bud.

42. The tooth bud ablation procedure of claim 1, said step of at least partially ablating at least one tooth bud further comprising the step of at least partially ablating at least one tooth bud without ablating surrounding tissue.

43. The tooth bud ablation procedure of claim 1 wherein said step of guiding placement of an ablation probe tip having a center of ablation so that said center of ablation is in the measured middle of a tooth bud further comprises guiding placement of an ablation probe tip to a computed pre-defined angle and depth of ablation based on information obtained from said volume scan images.

44. The tooth bud ablation procedure of claim 1, wherein said step of physically seating a custom surgical stent having at least one surgical guide so said at least one surgical guide corresponds to at least one tooth bud surgical site occurs prior to said step of using said at least one surgical guide, making a surgical access path at said at least one tooth bud surgical site.

45. The tooth bud ablation procedure of claim 1, wherein said step of physically seating a custom surgical stent having at least one surgical guide so said at least one surgical guide corresponds to at least one tooth bud surgical site occurs prior to said step of using said at least one surgical guide, guiding placement of an ablation probe tip having a center of ablation so that said center of ablation is in a measured middle of a tooth bud at said at least one tooth bud surgical site.

46. The tooth bud ablation procedure of claim 1, wherein said step of physically seating a custom surgical stent having at least one surgical guide so said at least one surgical guide corresponds to at least one tooth bud surgical site occurs prior to said step of using said at least one surgical guide, making a surgical access path at said at least one tooth bud surgical site and prior to said step of using said at least one surgical guide, guiding placement of an ablation probe tip having a center of ablation so that said center of ablation is in a measured middle of a tooth bud at said at least one tooth bud surgical site.

47. A human third molar tooth bud ablation procedure that results in tooth agenesis, the tooth bud ablation procedure comprising:

(a) physically seating a custom surgical stent fabricated for a specific patient having at least one surgical guide so said at least one surgical guide corresponds to at least one tooth bud surgical site, said at least one surgical stent fabricated using a process comprising:

(i) physically seating dental impression material in a patient's mouth, said dental impression material being visible in a volume scan;

(ii) generating a volume scan in which hard tissue is visible and said impression material is visible, and soft tissue being "visible" as the space between the visible hard tissue and the visible impression material; and

(iii) providing results of said step of generating a volume scan for the purpose of manufacturing or fabricating said custom surgical stent having at least one surgical guide for guiding placement of an ablation probe tip;

(b) using said at least one surgical guide, making a surgical access path at said at least one tooth bud surgical site;

(c) using said at least one surgical guide, guiding placement of an ablation probe tip having a center of ablation

33

so that said center of ablation is in a measured middle of a tooth bud at said at least one tooth bud surgical site; and
 (d) at least partially ablating at least one tooth bud, said at least one tooth bud being the tooth bud of a human third molar.

48. A human third molar tooth bud ablation procedure that results in tooth agenesis, the tooth bud ablation procedure comprising:

(a) physically seating a custom surgical stent fabricated for a specific patient having at least one surgical guide so said at least one surgical guide corresponds to at least one tooth bud surgical site, said at least one surgical stent fabricated using a process comprising:

(i) physically seating dental impression material in a patient's mouth, said dental impression material being visible in a volume scan;

(ii) volume scanning said patient's mouth while said dental impression material is seated therein;

34

(iii) said step of volume scanning generating a volume scan in which hard tissue is visible and said dental impression material is visible, and soft tissue is "visible" as the space between the visible hard tissue and the visible dental impression material; and

(iv) providing the results of said step of volume scanning for the purpose of manufacturing or fabricating said custom surgical stent having at least one surgical guide for guiding placement of an ablation probe tip;

(b) using said at least one surgical guide, making a surgical access path at said at least one tooth bud surgical site;

(c) using said at least one surgical guide, guiding placement of an ablation probe tip having a center of ablation so that said center of ablation is in a measured middle of a tooth bud at said at least one tooth bud surgical site; and

(d) at least partially ablating at least one tooth bud, said at least one tooth bud being the tooth bud of a human third molar.

* * * * *